

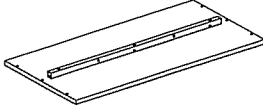

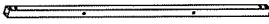

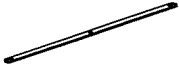

ASSEMBLY INSTRUCTION

A Leg Frame  2 pcs	B Wood Top  1 pc	C Tube  1 pc	D Metal Back Holder  2 pcs
E Allen wrench  1 pc	F Wrench  1 pc	G Bolt  6 pcs	H Nut  6 pcs
I Flat washer  10 pcs	J Bolt 1/4" X 12 mm  9 pcs	K Nut  1 pc	L Leveler  4 pcs

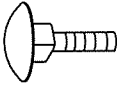

This page lists all the contents included in the box. Please take the time to identify the hardware as well as the individual components to this product. As you unpack and prepare for assembly, place the contents on a carpeted or padded area to protect them from damage.

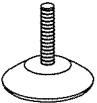
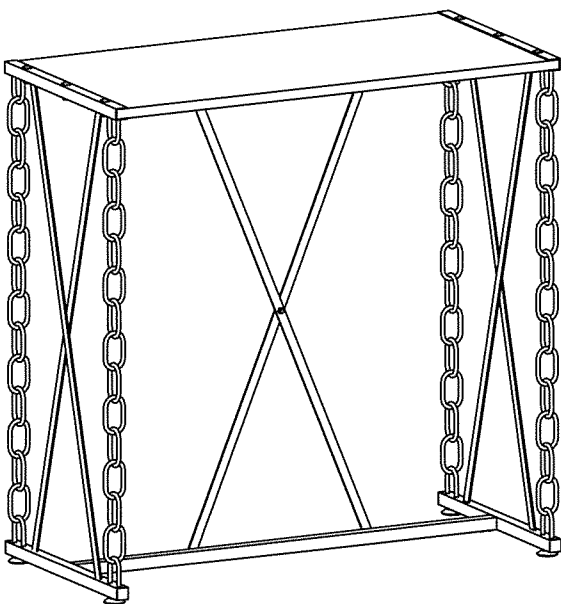
1

Insert the leveler (L) into the leg frame (A).

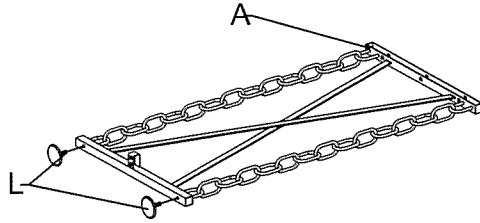





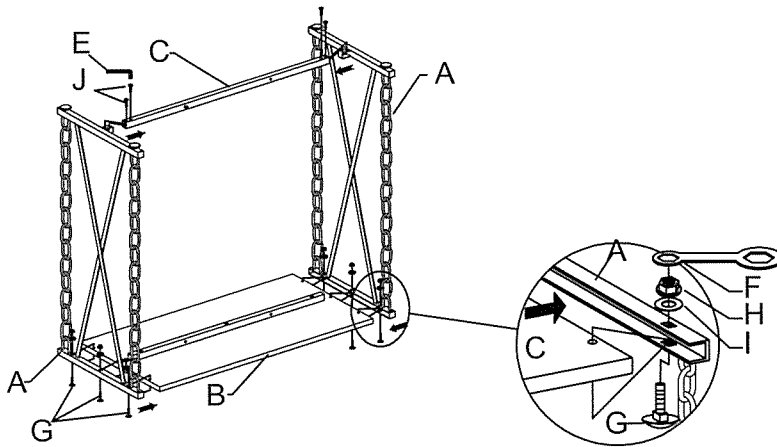

L  X 4 pcs

2

Assemble the leg frame (A), wood top (B) and tube (C) together then use the bolt (G) through the leg frame (A), wood top (B) and flat washer (I) into nut (H) as shown as drawing and tighten with the wrench (F). Use the bolt (J) through the tube (C) into leg frame (A).





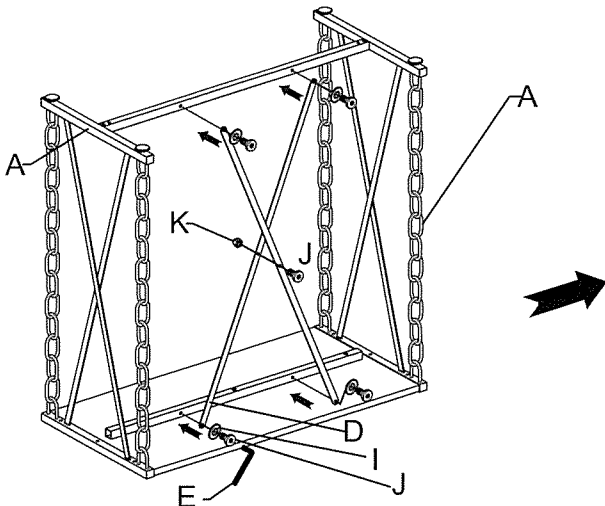

F  X 6 pcs
 E  X 6 pcs
 G  X 6 pcs
 H  X 6 pcs
 I  X 6 pcs
 J  X 4 pcs

3

Assemble the metal back holders (D) with the tube of wood top (B) and tube (C), using the bolt (J) through flat washer (I) into the tube (C) and wood top (B) then fastened using allen wrench (E). Screw the bolt (J) through the metal back holders (D) into nut (K). Upset the table.



E  X 5 pcs
 J  X 4 pcs
 I  X 4 pcs
 K  X 1 pc

Cleaning & Care

Treat surface with care. Surface is resistant to scratches but is not scratch resistant. Clean surfaces with a dry or damp soft cloth. Do not use abrasive cleaners. Hardware may loosen over time. Periodically check that all connections are tight.