

- |    |  |     |
|----|--|-----|
| 1  |  | x24 |
| 2  |  | x32 |
| 3  |  | x12 |
| 4  |  | x1  |
| 5  |  | x8  |
| 6  |  | x2  |
| 7  |  | x2  |
| 8  |  | x4  |
| 9  |  | x2  |
| 10 |  | x2  |
| 11 |  | x2  |
| 12 |  | x4  |
| 13 |  | x2  |

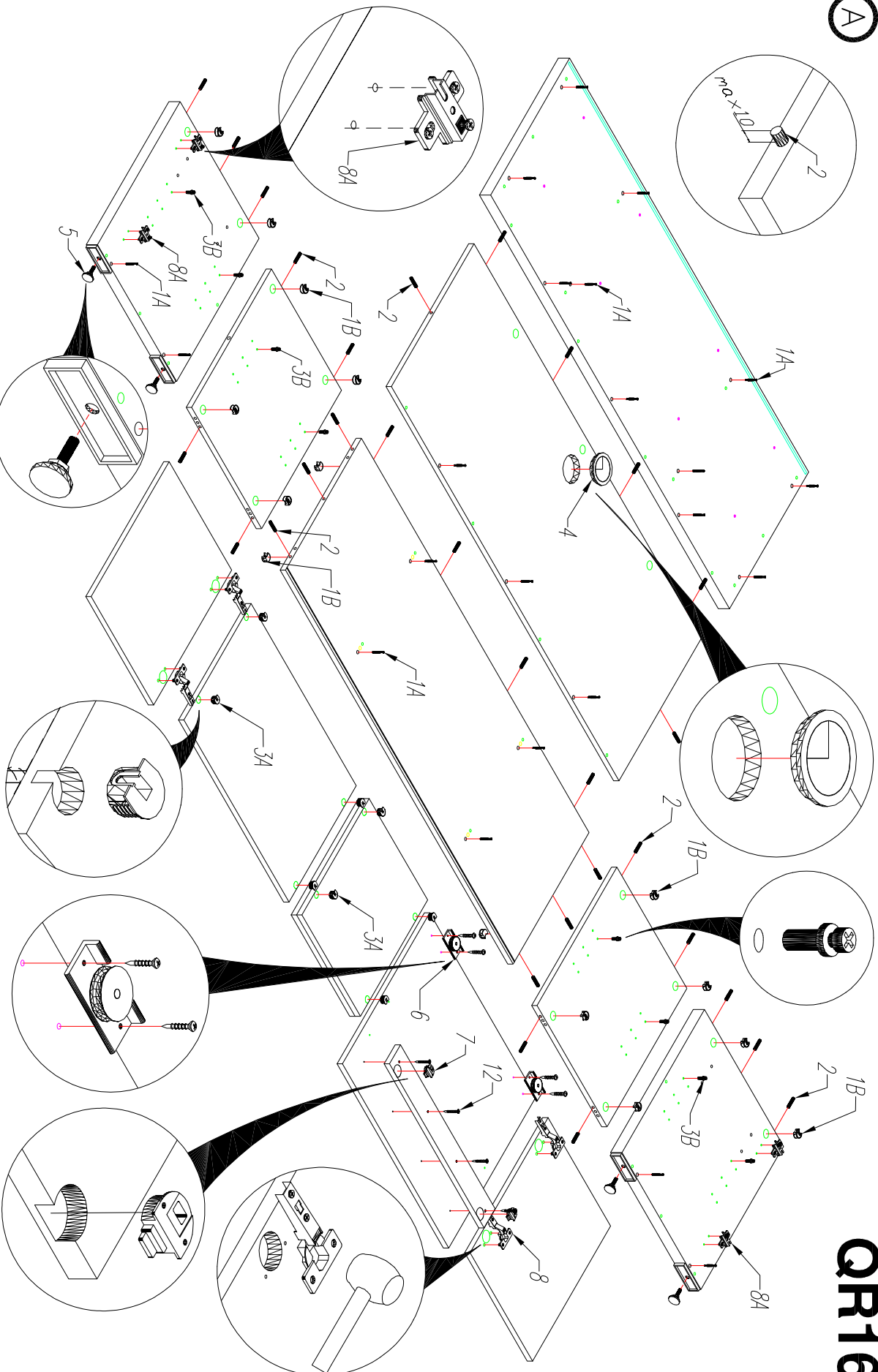

# QR16



(A)

KOLEJNOŚĆ MONTAŻU  
MONTÁŽOVÝ RÁDOK:  
THE FITNESS SEQUENCE OF THE  
CAM.  
DIE MONTAGEFOLGE VON  
EXZENTERN

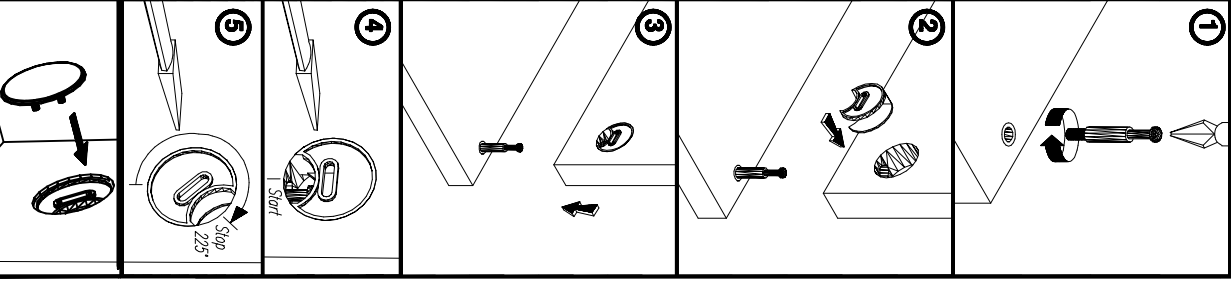

**B**

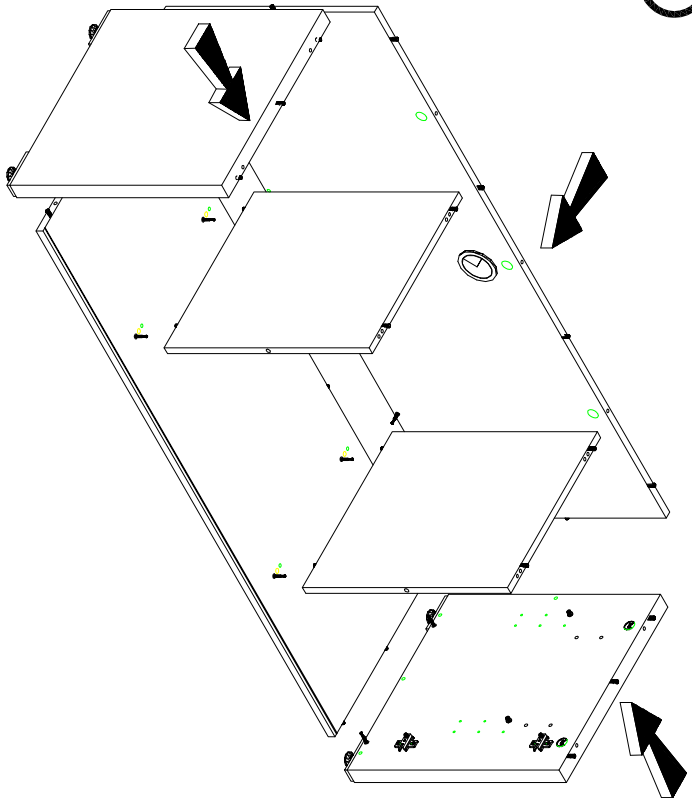

**C**

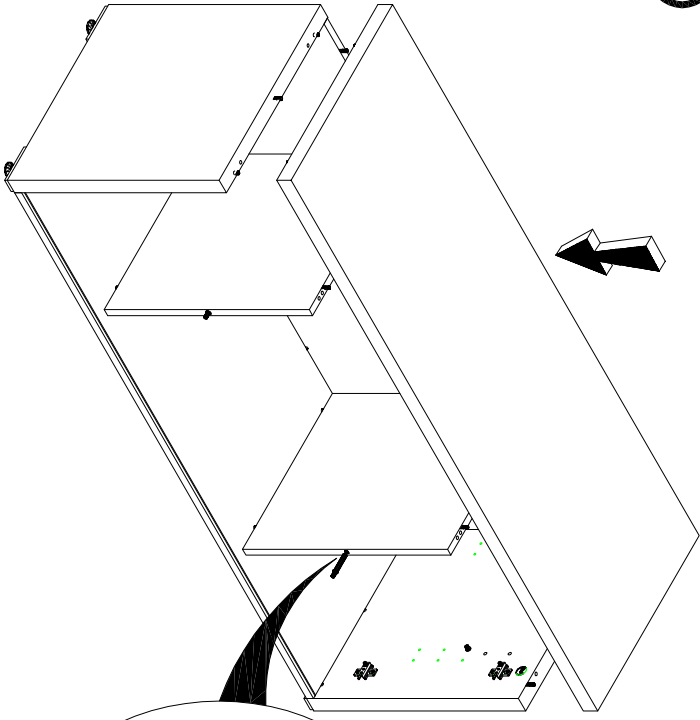

**D**

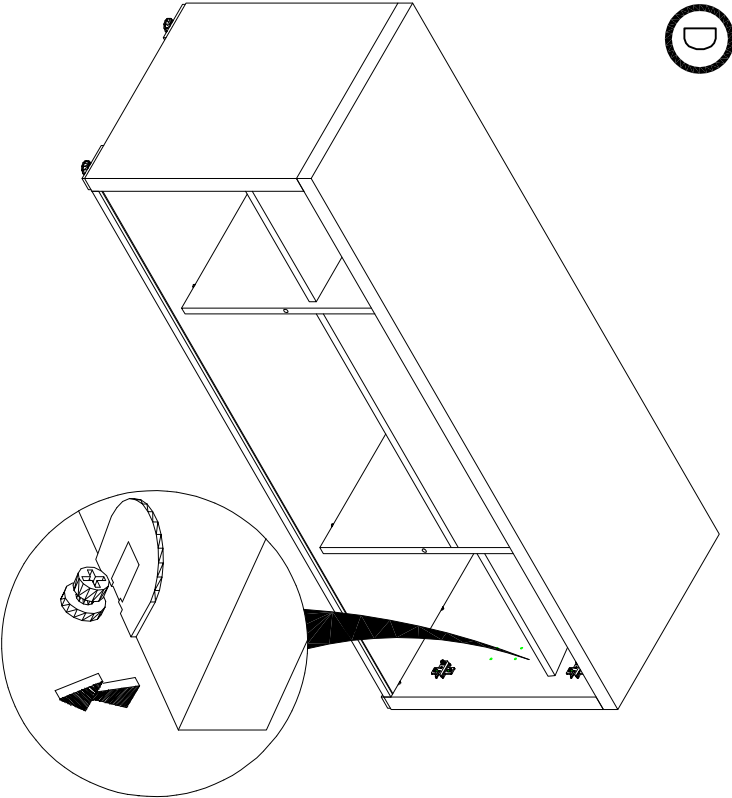

**E**

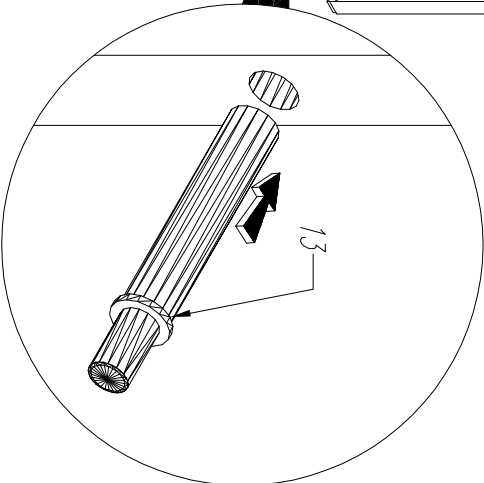
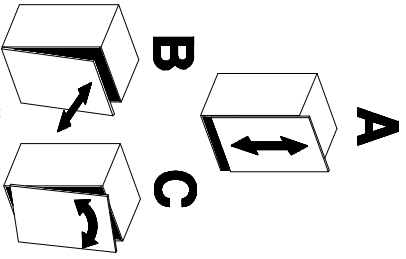
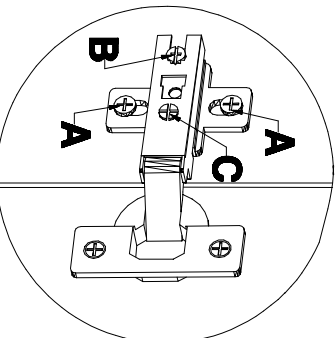
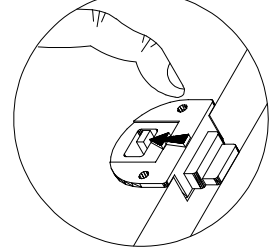
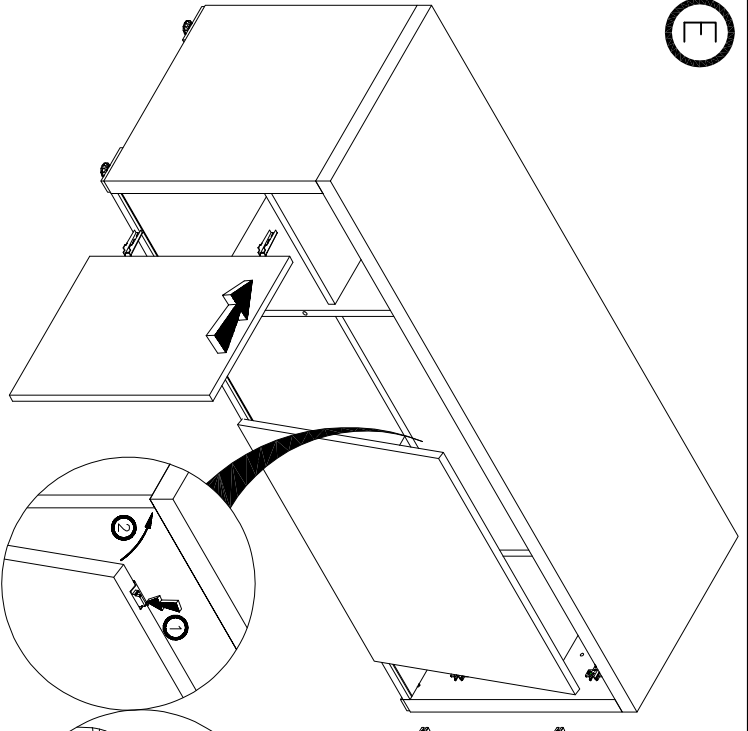

# QU19 QU16

