

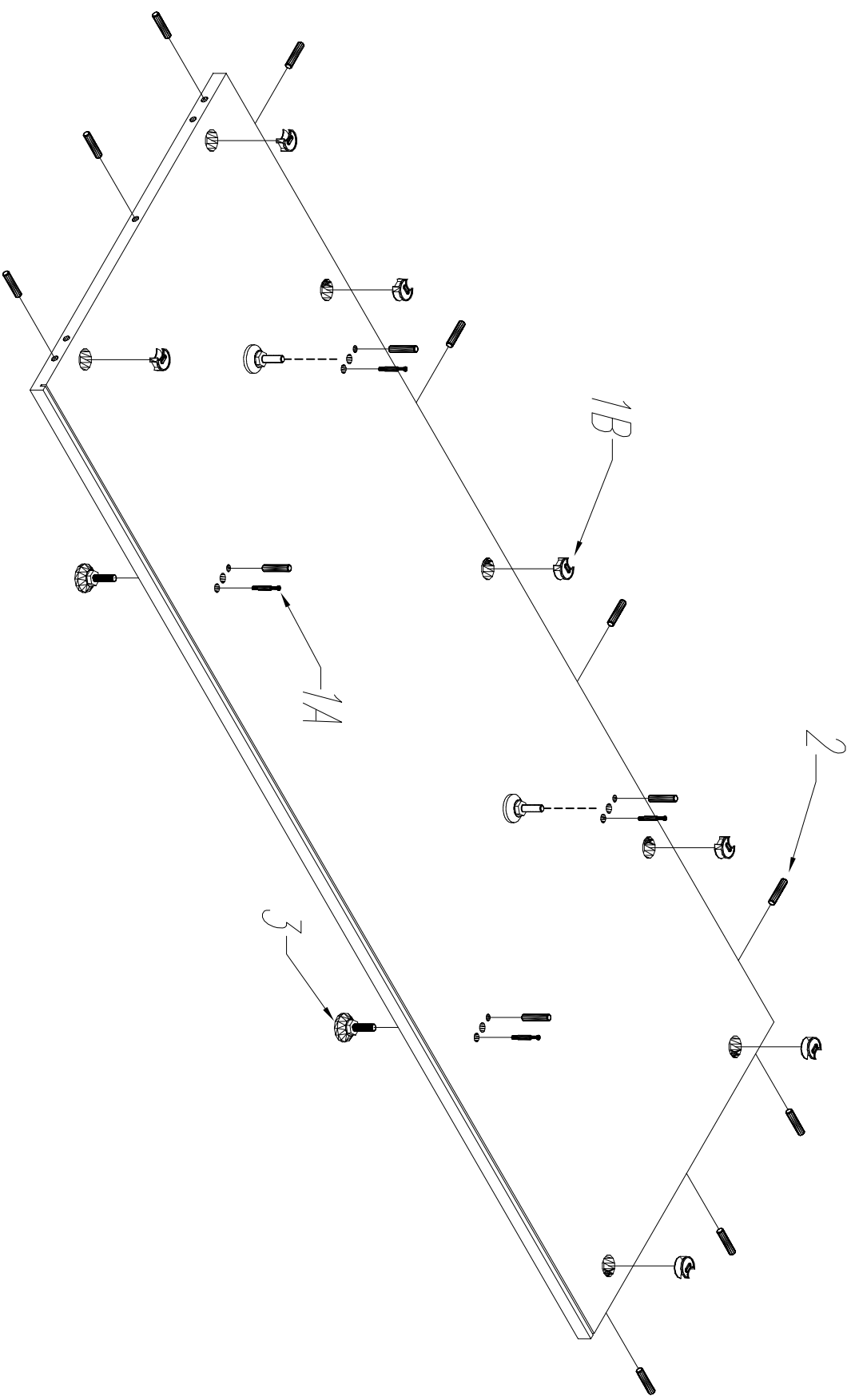

- | | |
|----|--|
| 1 | |
| 2 | |
| 3 | |
| 4 | |
| 5 | |
| 6 | |
| 7 | |
| 8 | |
| 9 | |
| 10 | |
| 11 | |

(A)



KOLENOSĆ MONTAZU
MIMOSRODOW.
THE FITTING SEQUENCE OF THE
CAMS.
DIE MONTAGEABFOLGE VON
EXZENTERN.

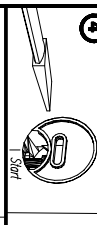
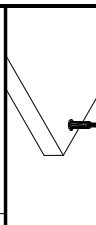
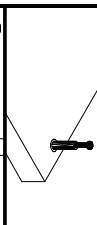
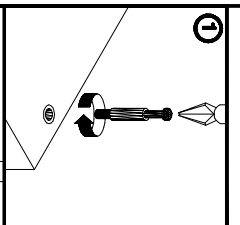

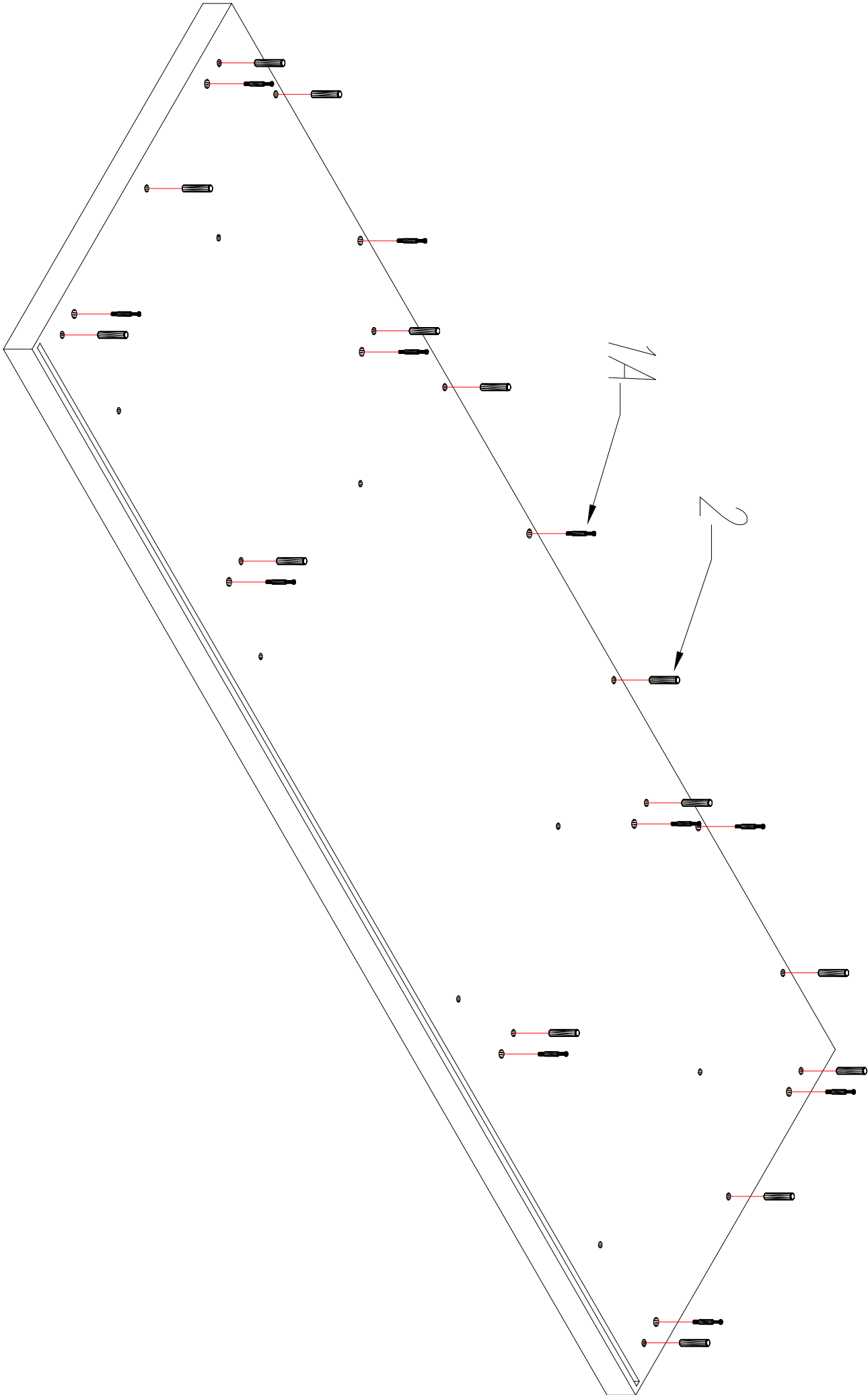

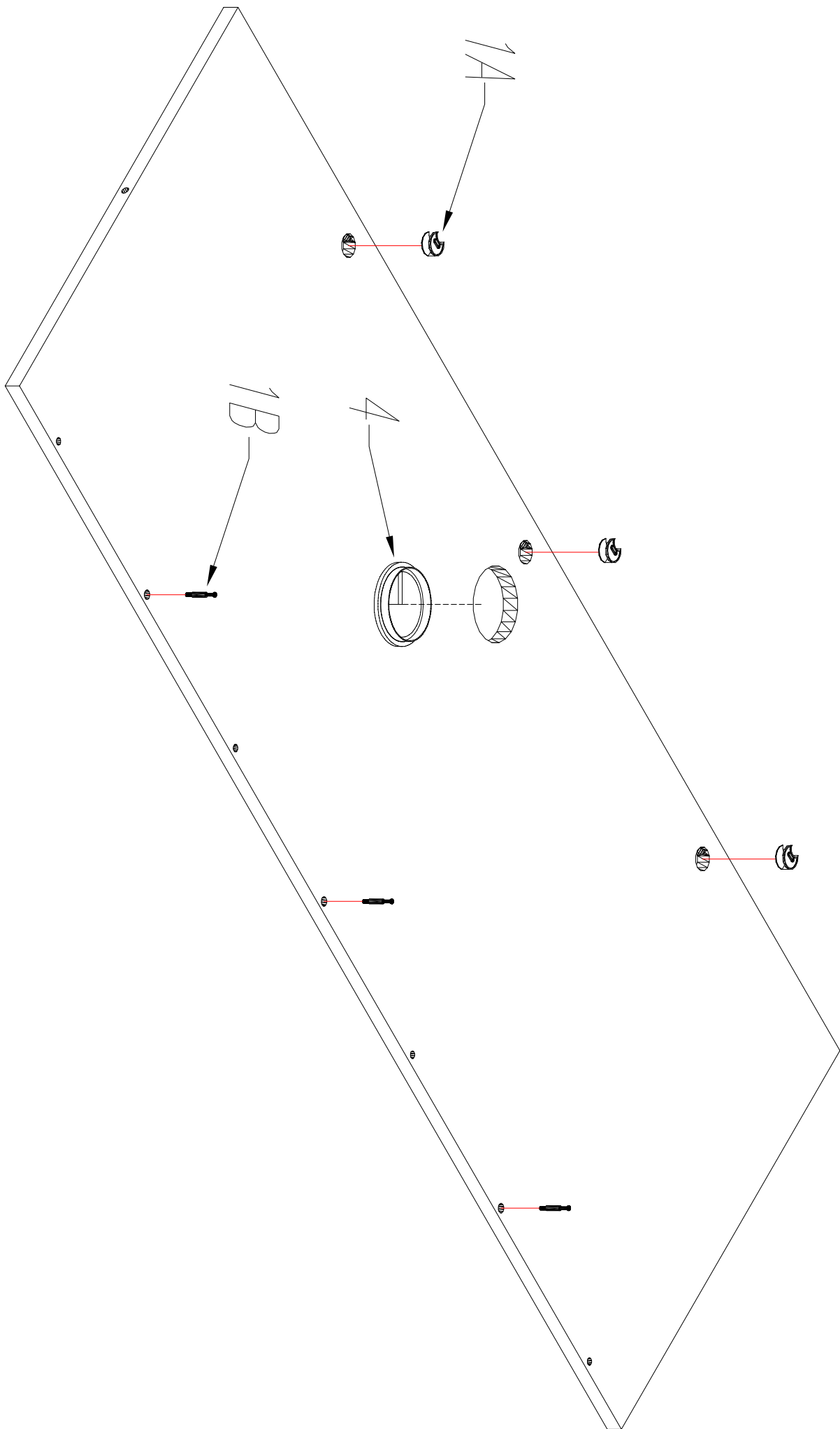

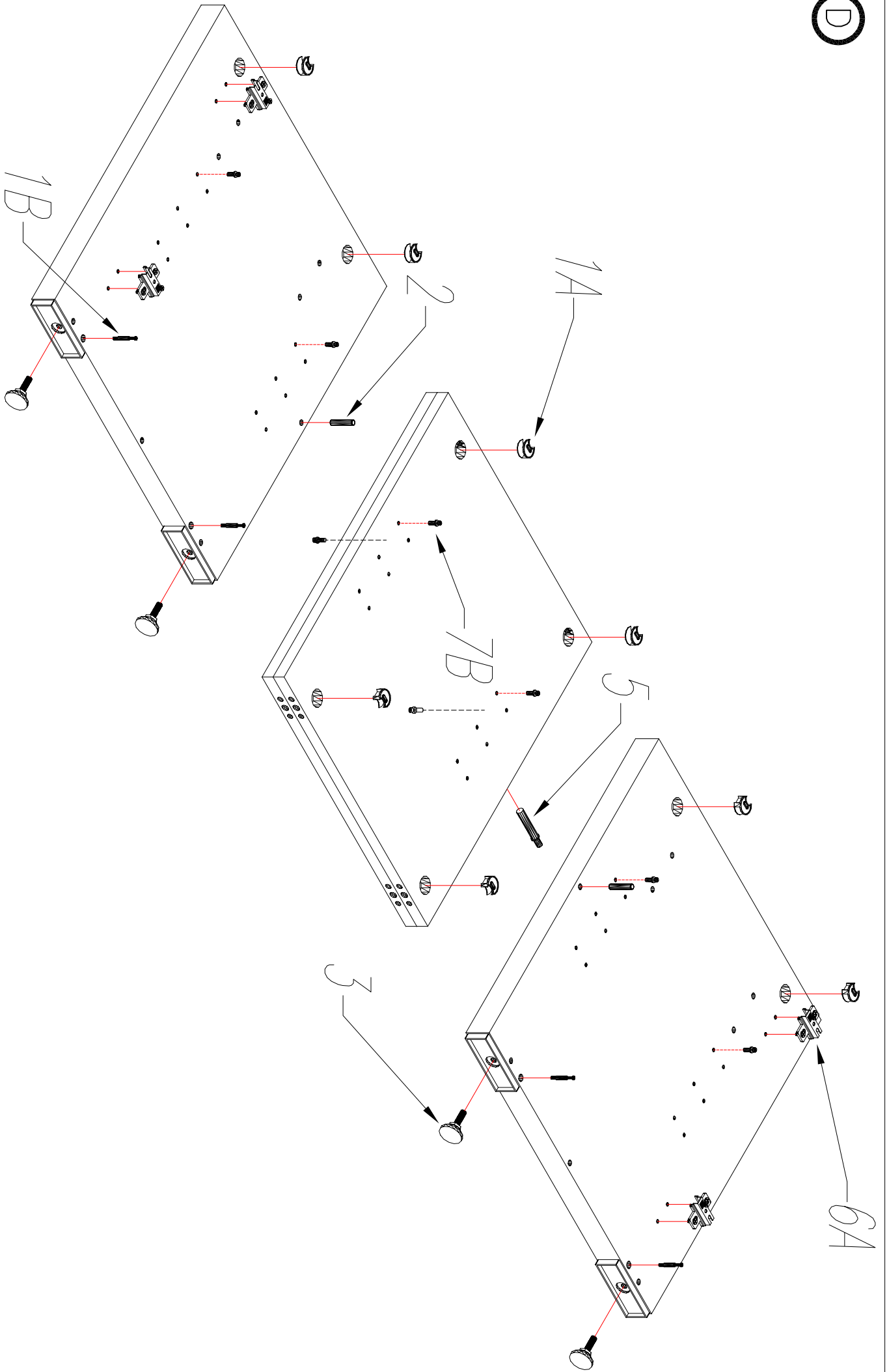

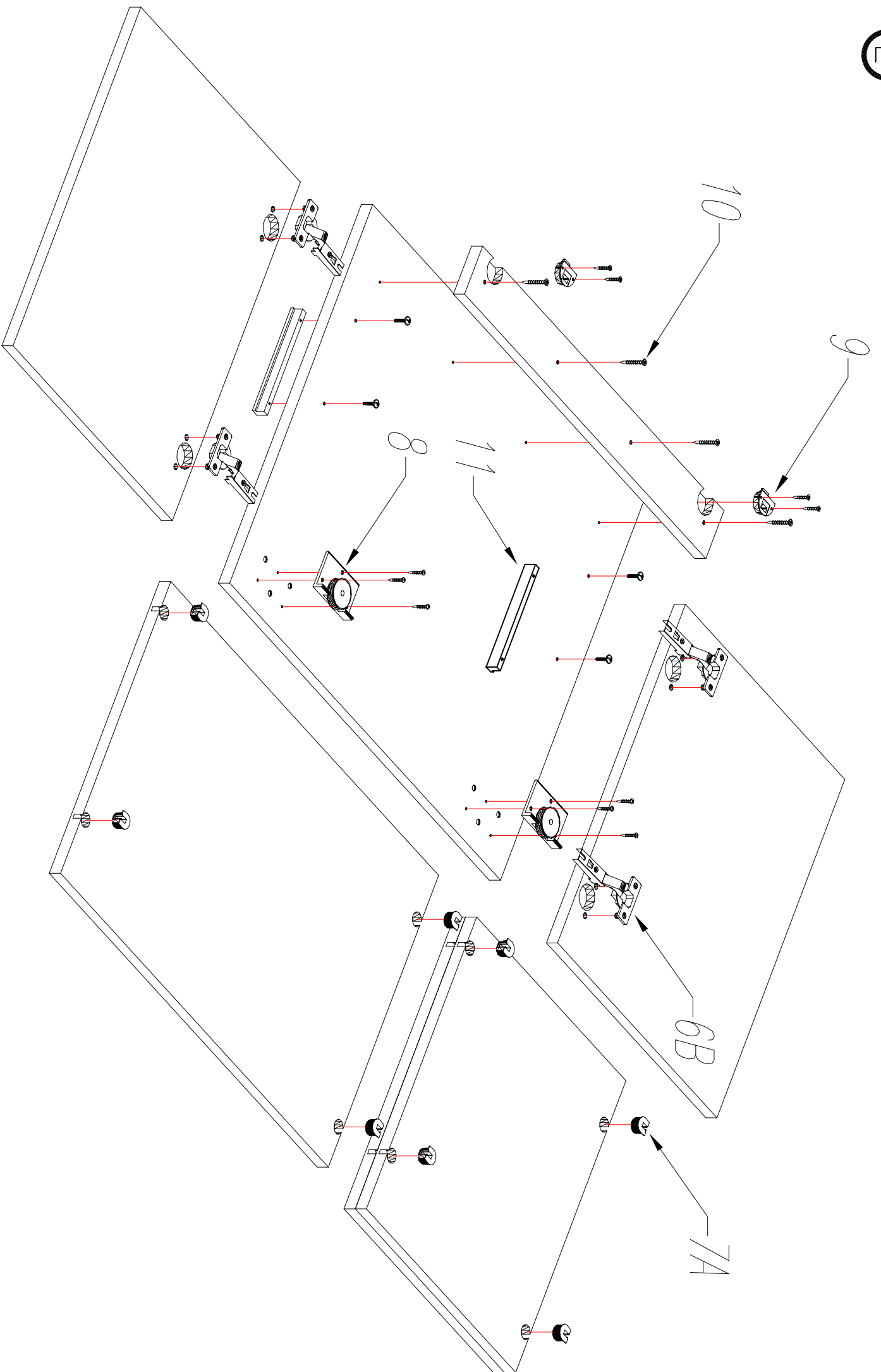

Ⓘ

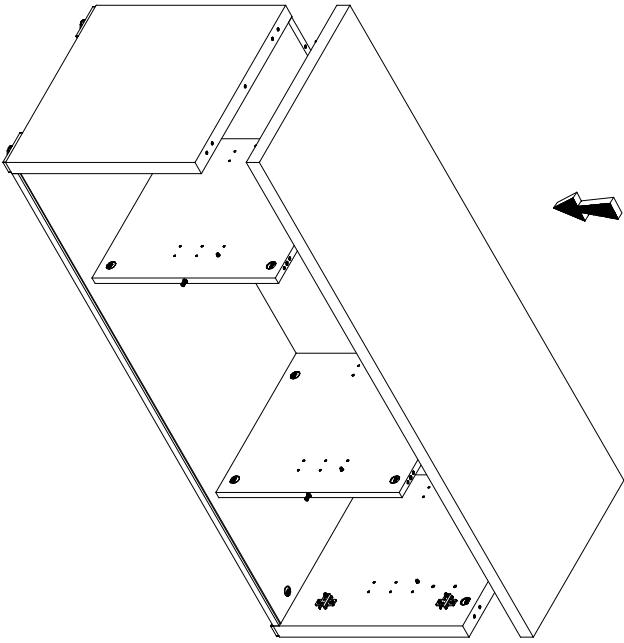

Ⓣ

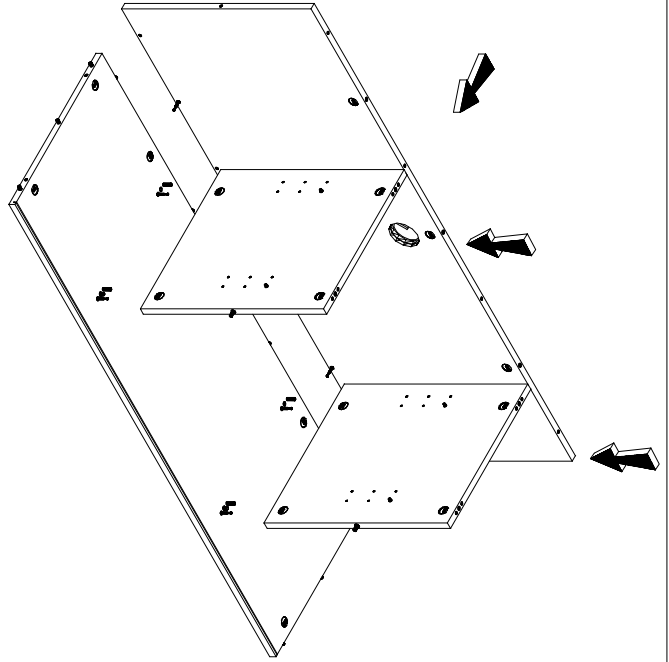

Ⓛ

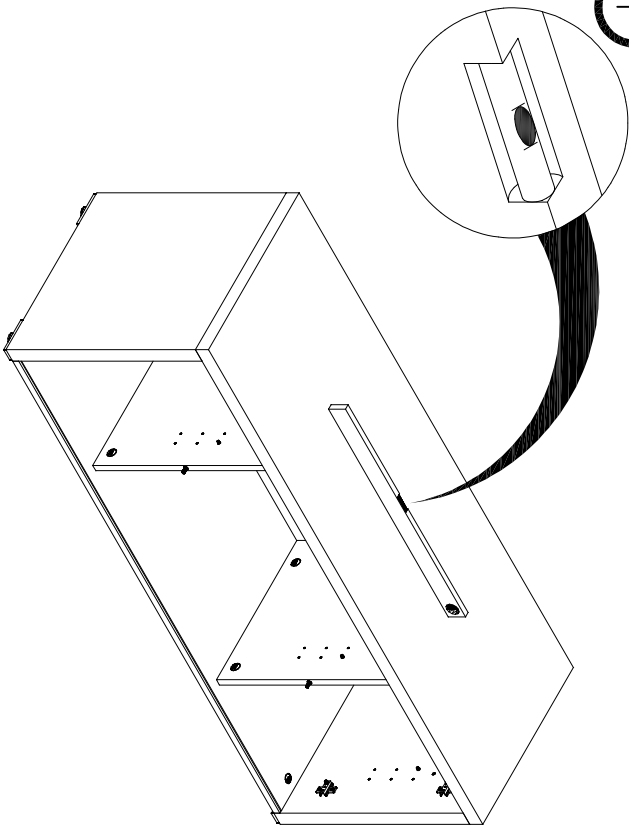

ⓖ

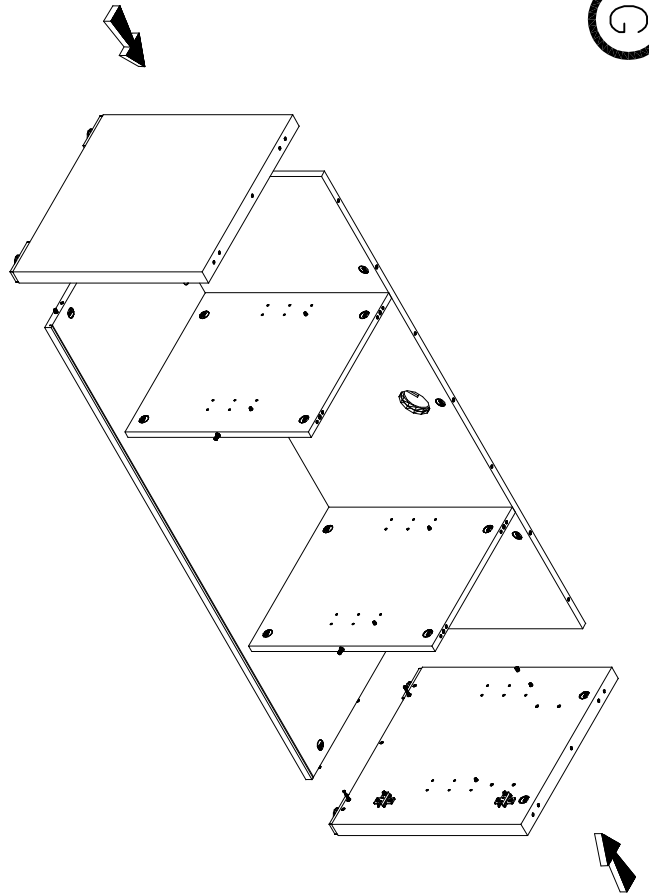

K

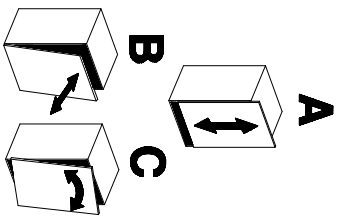
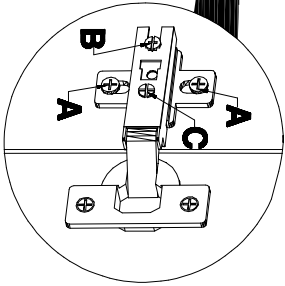
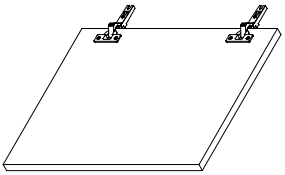
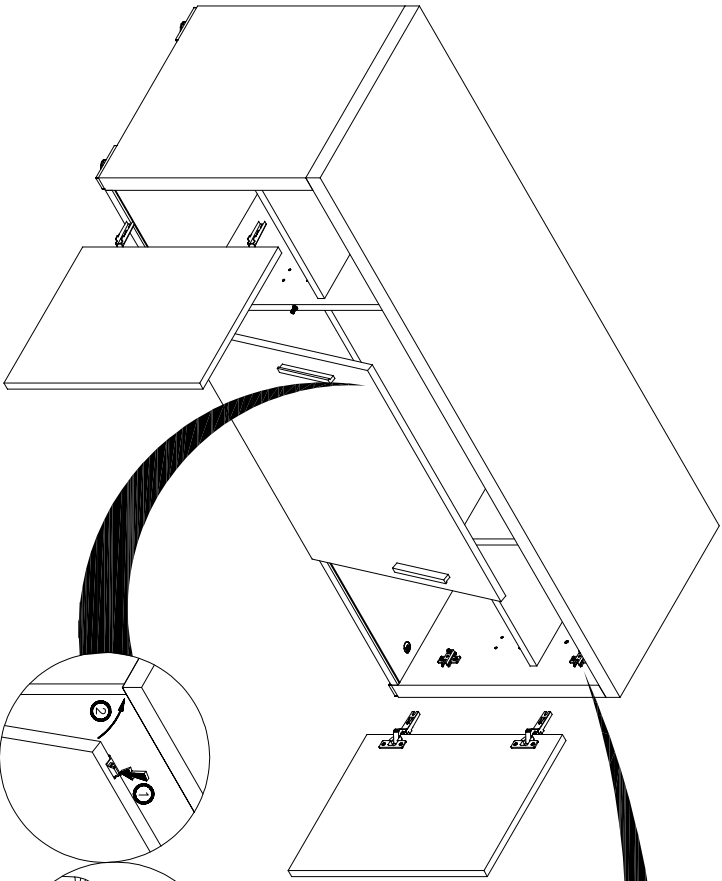

J

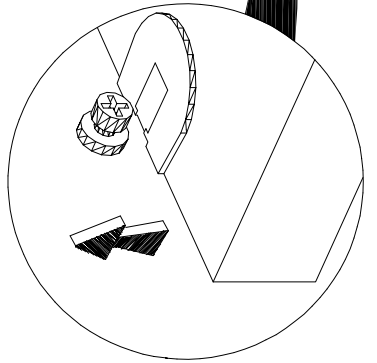
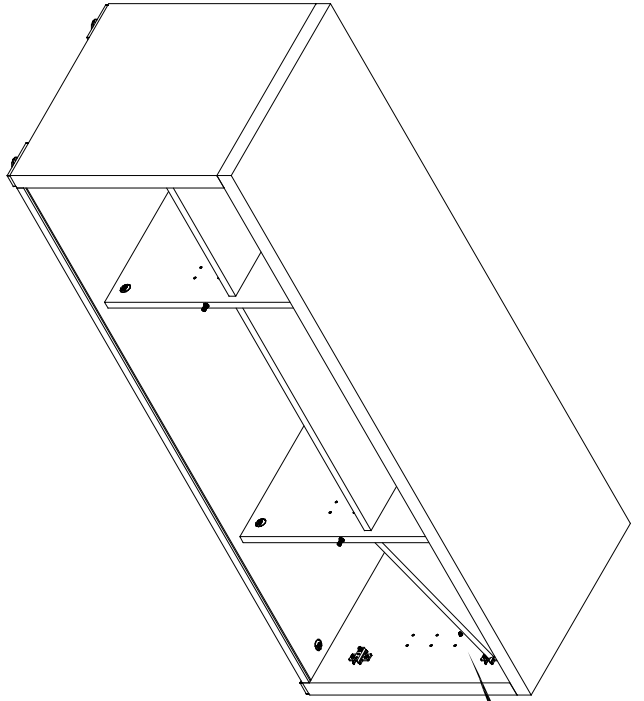

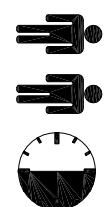

Q16_Q19

KOLEJNOŚĆ MONTAŻU
MIMOSRODOW.
THE FITTINGS SEQUENCE OF THE
CAMs.
DIE MONTAGEFOLGE VON
EXZENTERN.

1		x6
2		x4
3		x4
4		x4
5		x4
6		x4
7		x4
8		x4

(A)

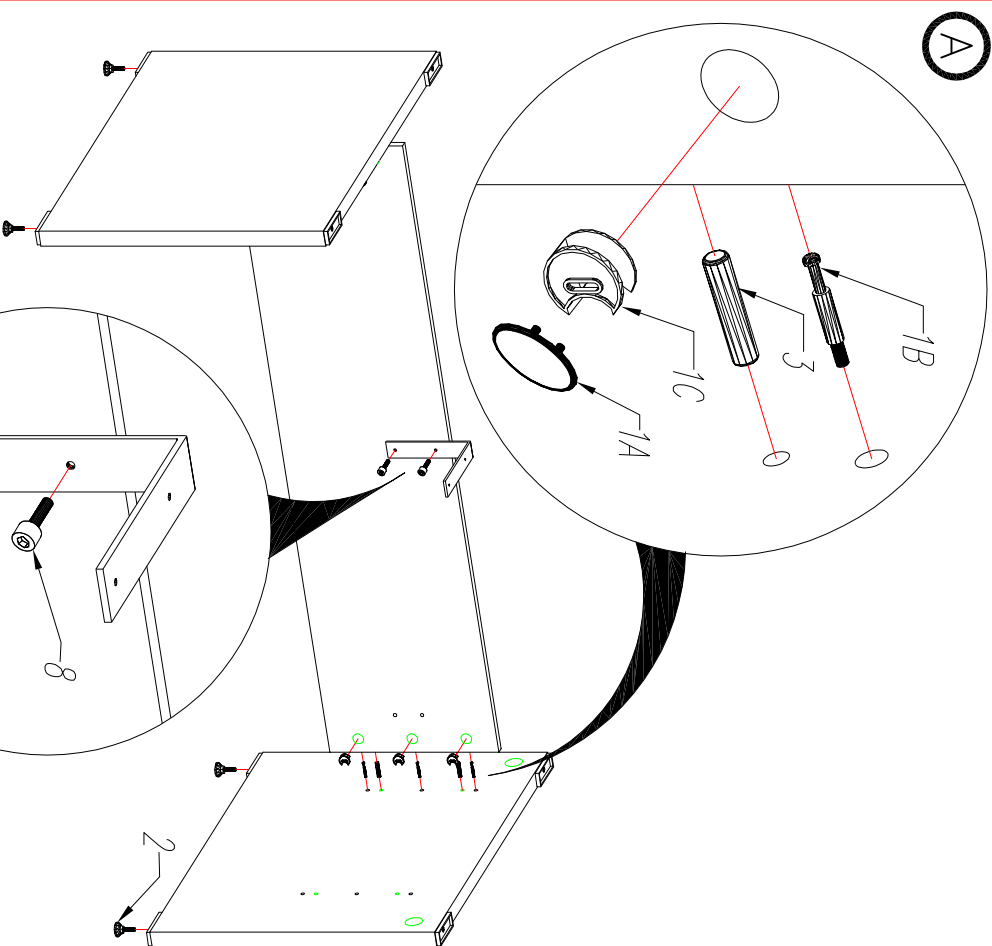

(B)

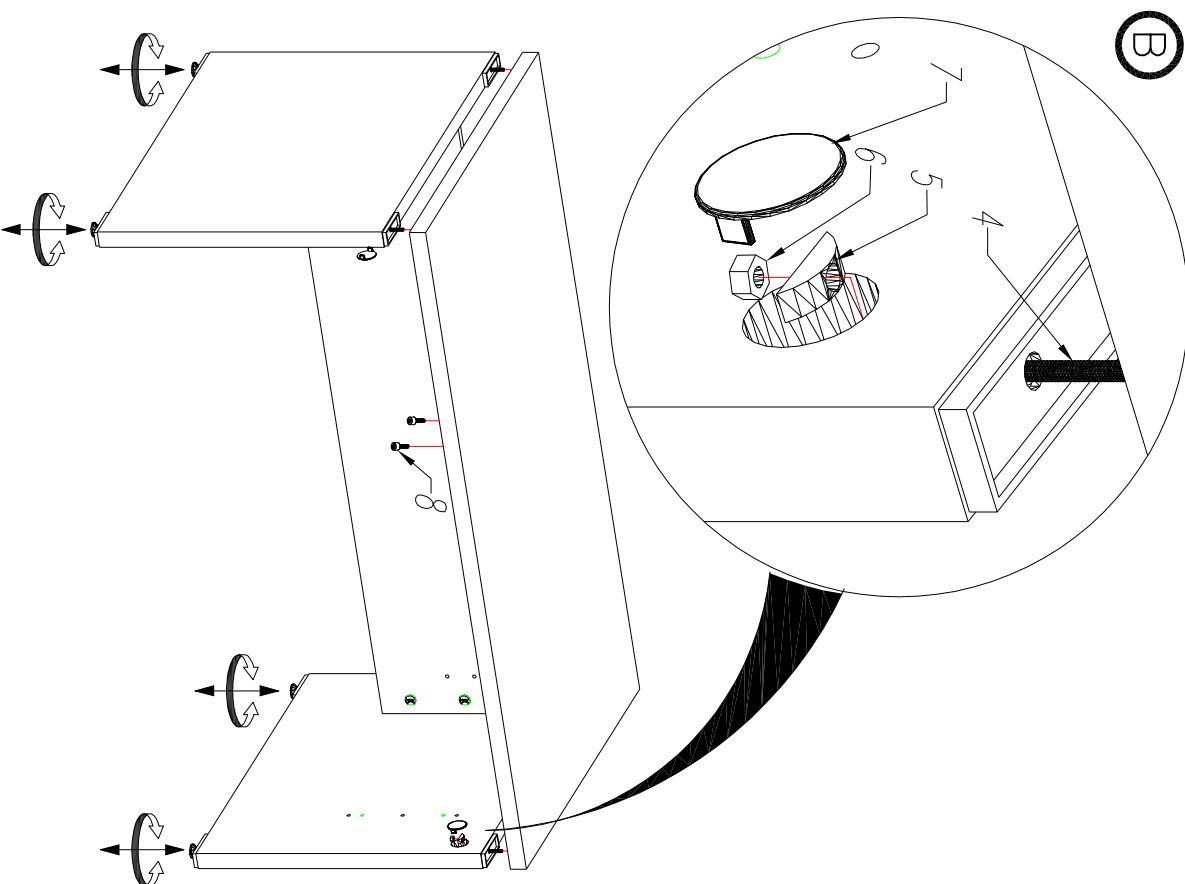

①

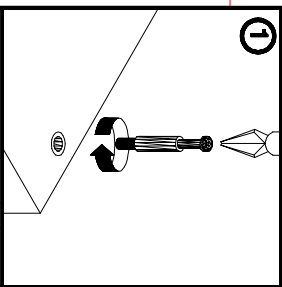

②

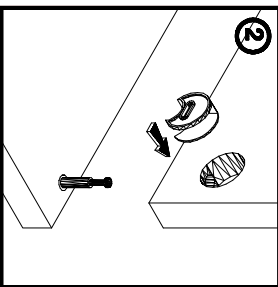

③

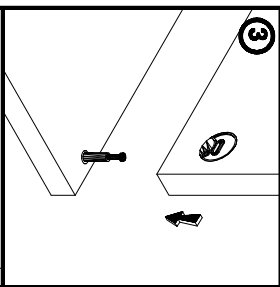

④

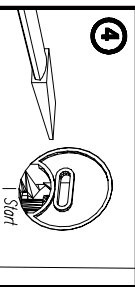

⑤

