

Assembly Instructions

CM7946

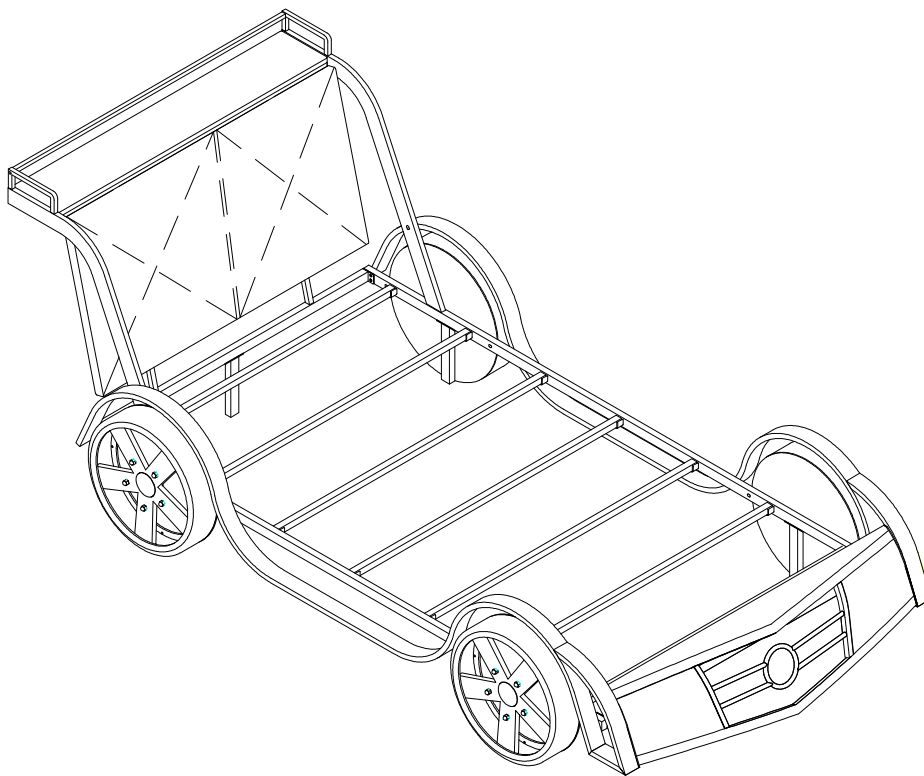

ASSEMBLY RATING

The Assembly Rating is a 5-point system that shows the degree of effort needed in assembling a specific product (with 1 being easy and 5 being difficult). For some products, two persons are recommended.

EASY  DIFFICULT

Tools Required For Assembly:

Allen Wrench

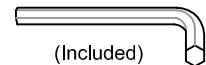

Phillips Screwdriver

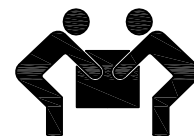
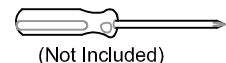

2 PERSONS RECOMMENDED

ASSEMBLY & CARE ADVICE

FOR YOUR FURNITURE TO LAST, CORRECT ASSEMBLY AND PROPER MAINTENANCE ARE NECESSARY. PLEASE FOLLOW THE INFORMATION PROVIDED BELOW TO FULLY ENJOY YOUR FURNITURE.

BASIC ASSEMBLY TECHNIQUES

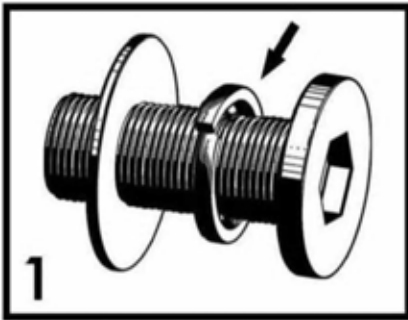

When lock or spring washer is used in an assembly, please make sure the lock or spring washer is placed between the larger flat washer and the head of the screw or bolt.



Position each part correctly and insert screws or bolts into their respective holes by hand tighten or using the proper hand tool. Only tighten when step is completed or when instructed to do so.



Use cardboard or carpet area when assembling furniture to prevent scratches. Make sure the furniture rests on a flat and level surface with each leg evenly touching the floor.

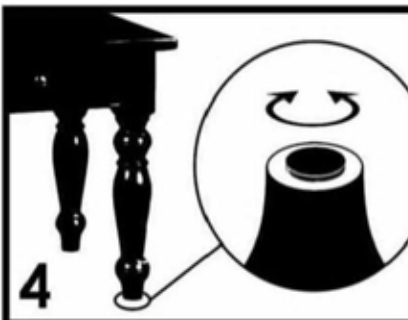

Some furniture comes with height adjustment knobs underneath each leg. To lower or to raise each leg, you need to turn clockwise or counterclockwise, respectively.

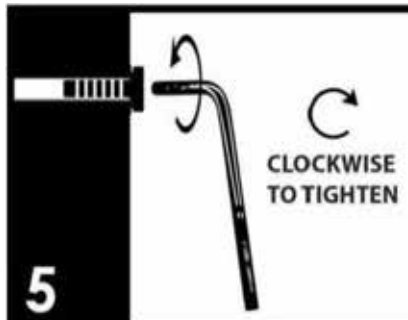

Make sure all parts are properly aligned, then use the appropriate hand tool to completely tighten the bolts or screws. Do not use power tools and do not overtighten.



Save the instructions and store the Allen wrench or any supplied tool for later maintenance. After two weeks, check and tighten any loose hardware and repeat again every six months thereafter.

IT IS THE USER'S RESPONSIBILITY TO MAINTAIN THE FURNITURE. THE HARDWARE MAY LOOSEN OVER TIME AND MAY CAUSE THE FURNITURE TO BE WOBBLY AND UNABLE TO SUPPORT ITS INTENDED WEIGHT CAPACITY. THIS MAY LEAD TO COLLAPSE AND MAY CAUSE SERIOUS INJURY.

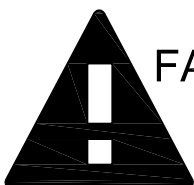

FAILURE TO FOLLOW THE GUIDELINES ABOVE MAY RESULT IN INJURY AND/OR PROPERTY DAMAGE.



Before you begin, please read Page 2 of "Assembly and Care Advice".

And remember, do not tighten until each step is completed or instructed.

Parts List



#1 x 1pc
Left Side Rail

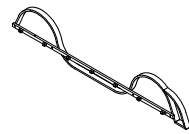

#2 x 1pc
Right Side Rail

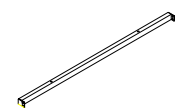

#3 x 1pc
Headboard connect

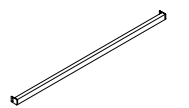

#4 x 1pc
Footboard connect

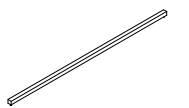

#5 x 7pcs
Rail

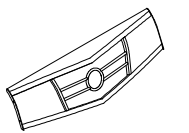

#6 x 1pc
Footboard

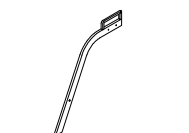

#7 x 1pc
Headboard Support A



#8 x 1pc
Headboard Support B

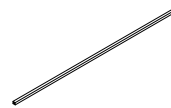

#9 x 1pc
Headboard Up connect

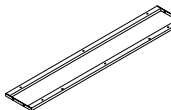

#10 x 1pc
Headboard Up Tube Frame



#11 x 1pc
Headboard Frame

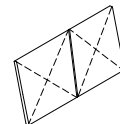

#12 x 1pc
Headboard

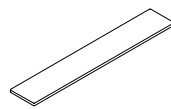

#13 x 1pc
Panel



#14 x 5pcs
Support Leg



#15 x 4pcs
Wheel



Before you begin, please read Page 2 of "Assembly and Care Advice".

And remember, do not tighten until each step is completed or instructed.

Hardware List



#A x 4pcs
BOLT 1/4"X1-3/4"

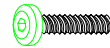

#B x 8pcs
BOLT 1/4"X1-3/8"



#C x 8pcs
BOLT 1/4"X1"



#D x 24pcs
BOLT 1/4"X1/2"



#E x 2pcs
BOLT 1/4"X1-1/4"



#F x 1pc
Allen Wrench M4



#G x 6pcs
Screw



#H x 6pcs
Washer



I. Carefully place the left side rail (#1) on a protected surface. Align the headboard support A (#7) to the pre-drilled hole on the left side rail (#1). Insert bolt (#C) and secure using the Allen wrench (#F).

#A x 1pc
#C x 1pc
#D x 3pcs

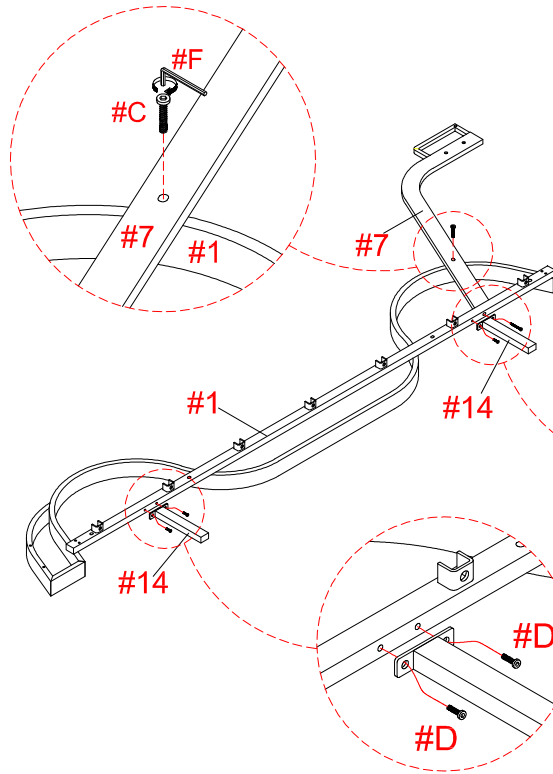

II. Align a support leg (#14) to the other side of the left side rail (#1). Insert bolt (#A) into the large pre-drilled hole and bolt (#D) into the small pre-drilled hole. Secure using the Allen wrench (#F).

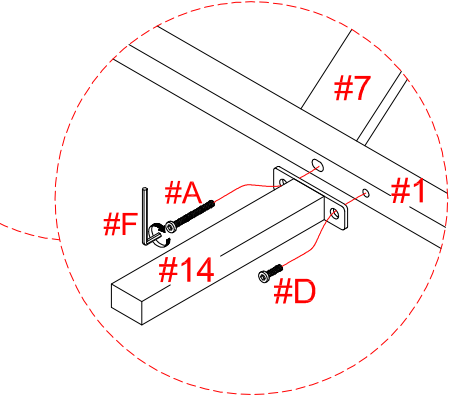

III. Align a support leg (#14) to the other pre-drilled hole on the left side rail (#1). Insert 2 bolts (#D) and secure using the Allen wrench (#F).



I. Carefully place the right side rail (#2) on a protected surface. Align the headboard support B (#8) to the pre-drilled hole on the right side rail (#2). Insert bolt (#C) and secure using the Allen wrench (#F).

#A x 1pc
#C x 1pc
#D x 3pcs

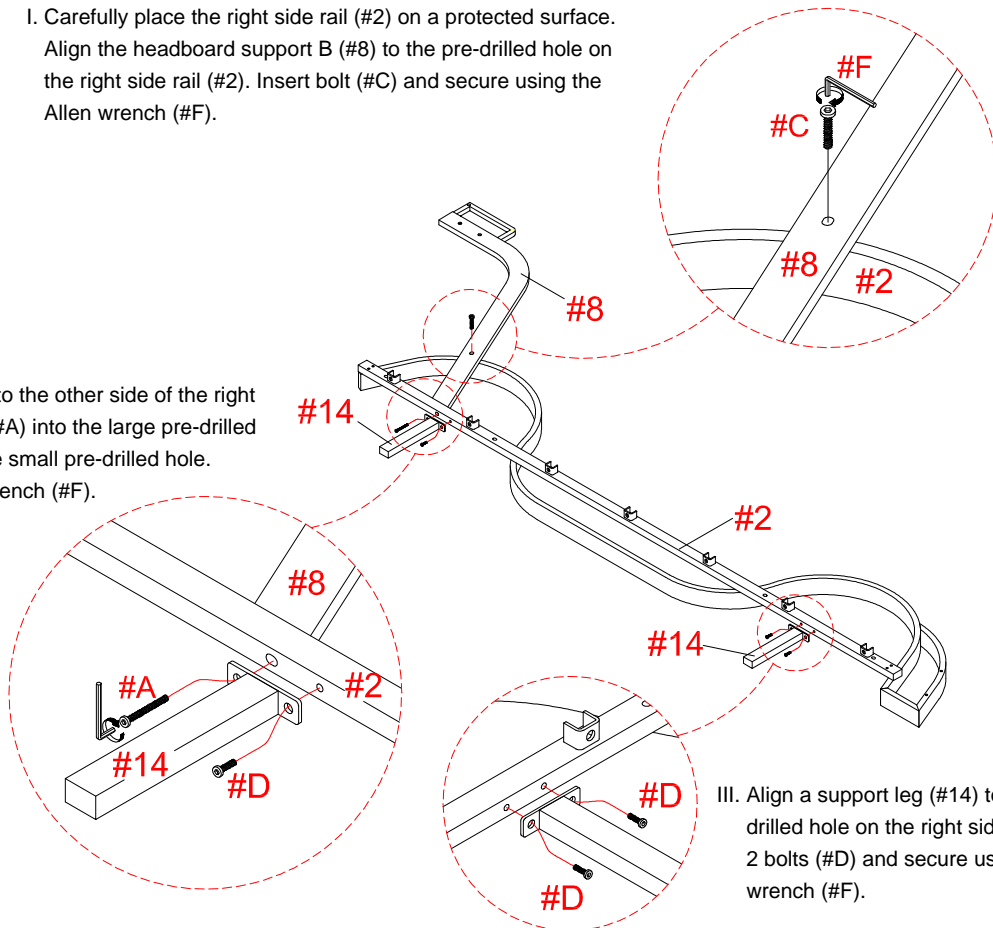

II. Align a support leg (#14) to the other side of the right side rail (#2). Insert bolt (#A) into the large pre-drilled hole and bolt (#D) into the small pre-drilled hole. Secure using the Allen wrench (#F).

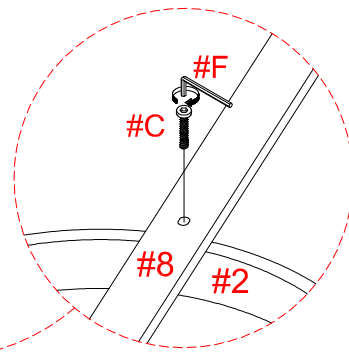

III. Align a support leg (#14) to the other pre-drilled hole on the right side rail (#2). Insert 2 bolts (#D) and secure using the Allen wrench (#F).



#3

#D x 2pcs

Align a support leg (#14) to the pre-drilled holes on the headboard connect (#3). Insert 2 bolts (#D) and secure using the Allen wrench (#F).

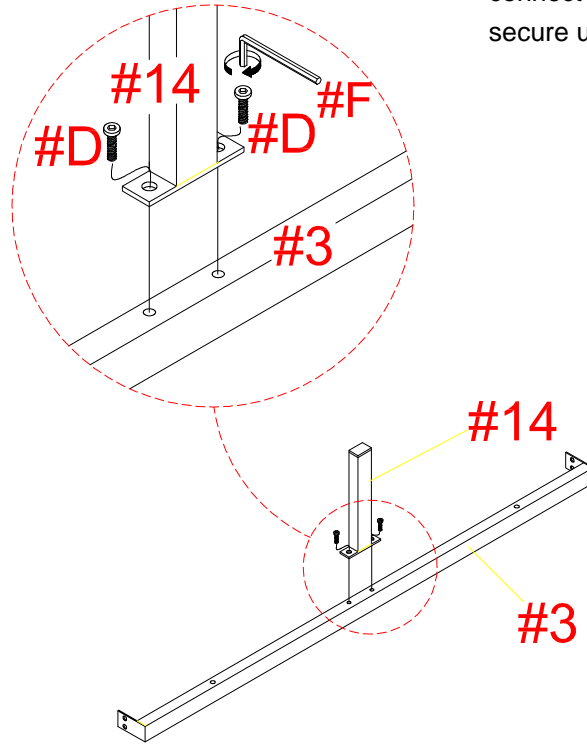

#4

#D x 8pcs

- I. Align the headboard connect (#3) to the right/left side rails (#1,2).
- II. Insert 2 bolts (#D) into each corner and secure using the Allen wrench (#F).

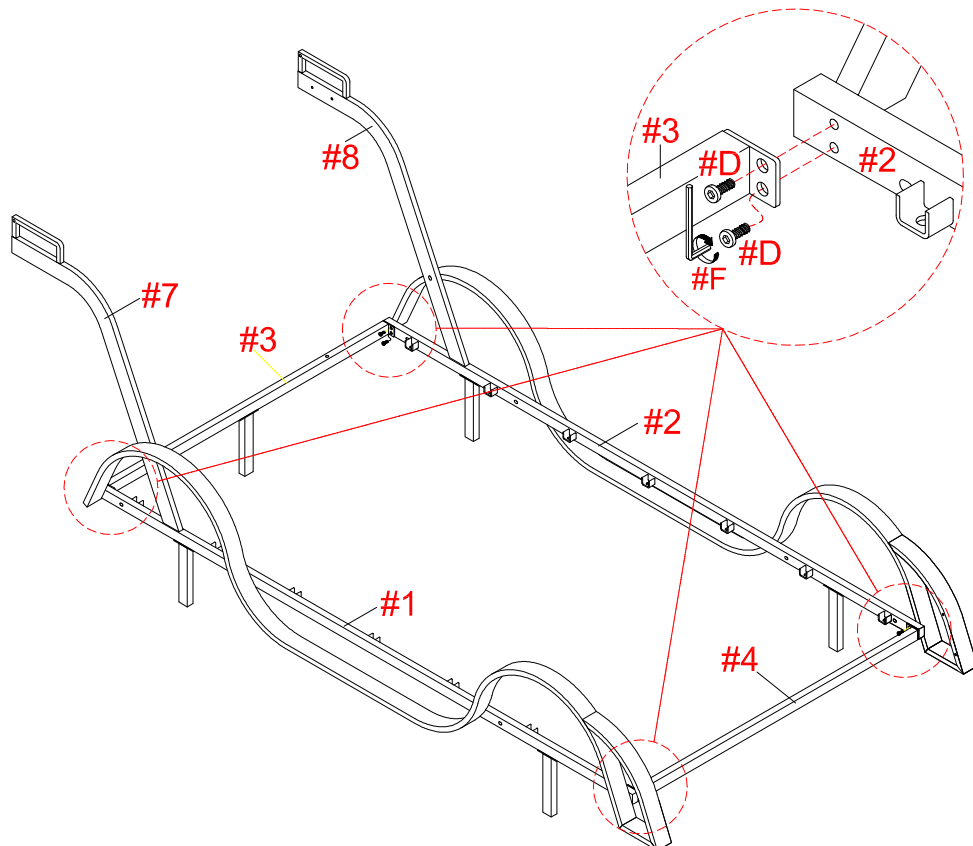



#C x 2pcs
#D x 4pcs

- I. Align the headboard up connect (#9) and headboard tube frame (#10) in between the headboard supports A/B.
- II. Insert 2 bolts (#C) to lock the headboard up connect (#9) and use 4 bolts (#D) to lock the headboard tube frame (#10). Secure using the Allen wrench (#F).

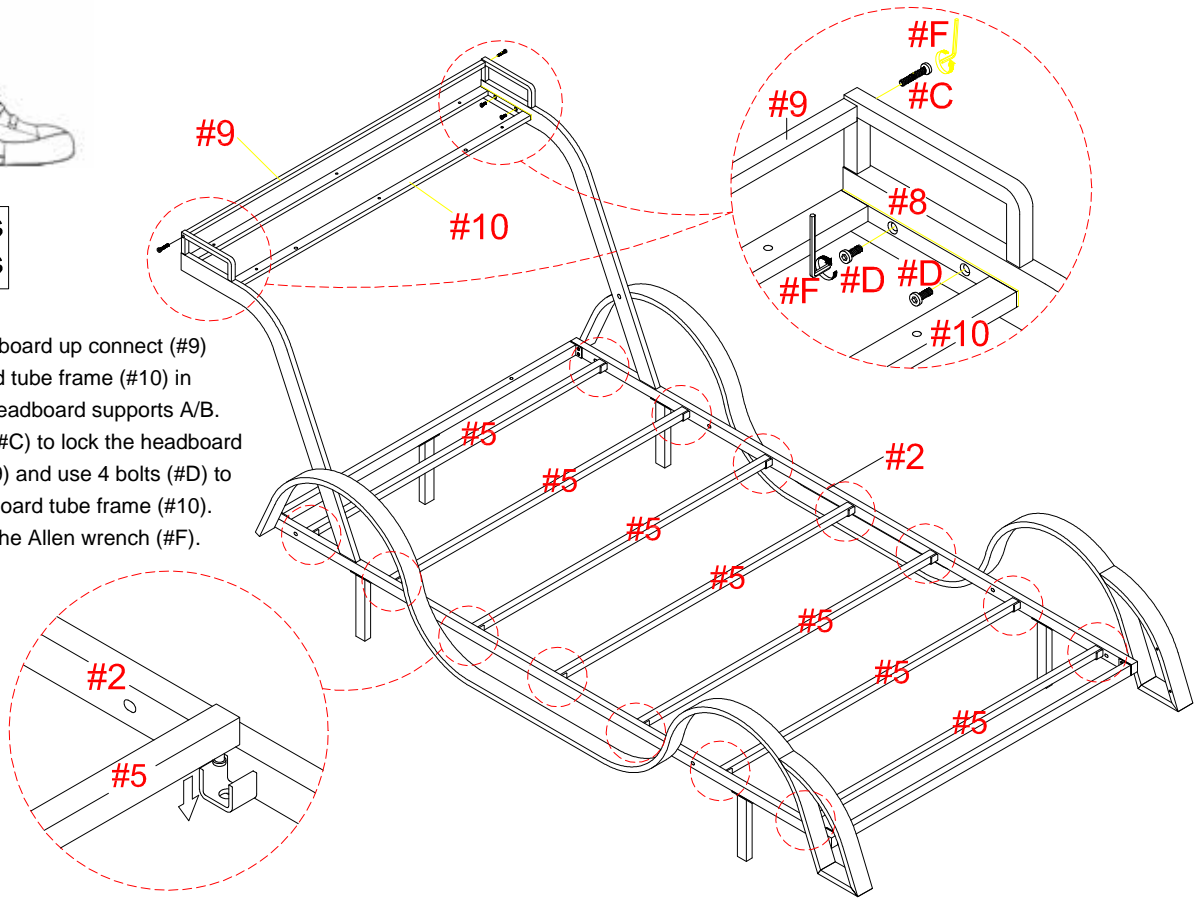

Insert 7 rails (#5) into the designated slots along the sides of the right/left side rails (#1,2).



#A x 2pcs
#E x 2pcs

- I. Align the headboard frame (#11) in between the headboard up tube frame (#10) and headboard connect (#3).
- II. Insert 2 bolts (#E) to the top and 2 bolts (#A) to the bottom and secure using the Allen wrench (#F).

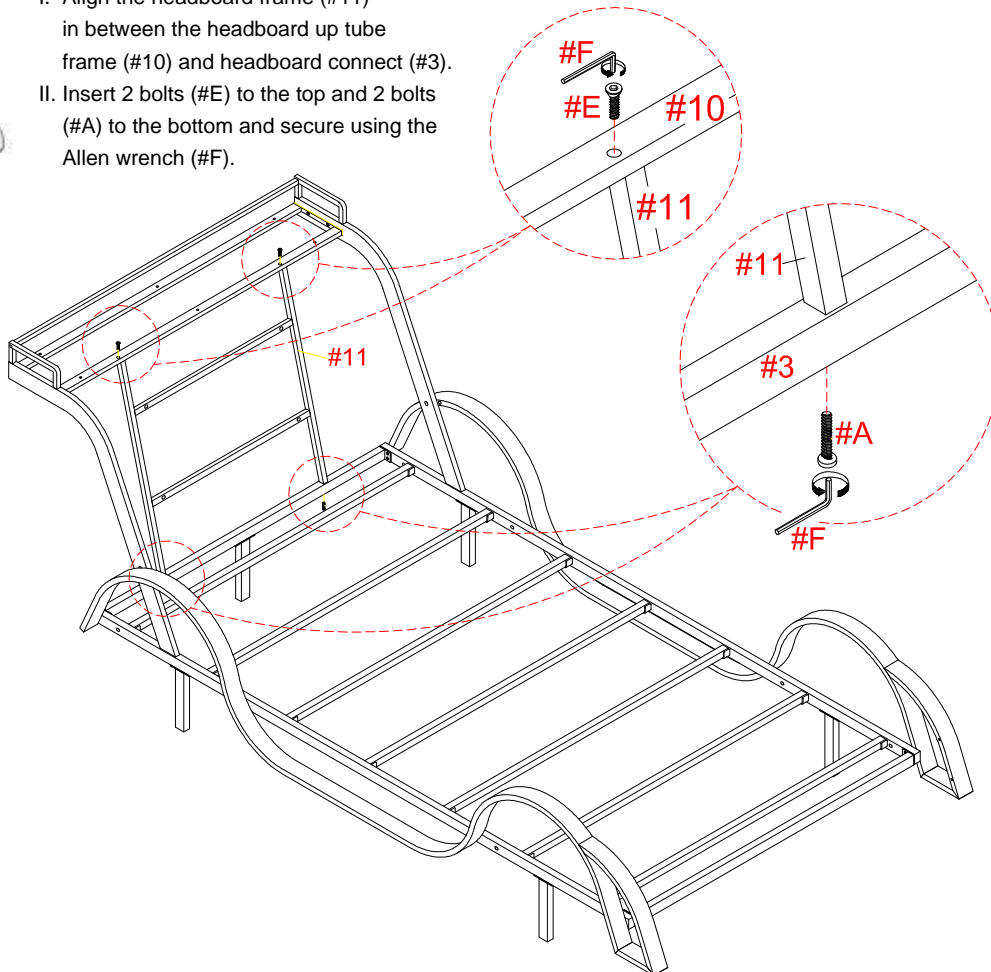



#C x 4pcs
#G x 6pcs
#H x 6pcs

- I. Align the panel (#13) to the headboard up tube frame (#10) and the headboard (#12) to the headboard frame (#11).
- II. Prepare 6 bolt assemblies by inserting a washer (#H) onto the screw (#G). Insert connect the panel (#13) and secure using the Phillips screwdriver.
- III. Insert 4 bolts (#C) to connect the headboard (#12) and secure using the Allen wrench (#F).

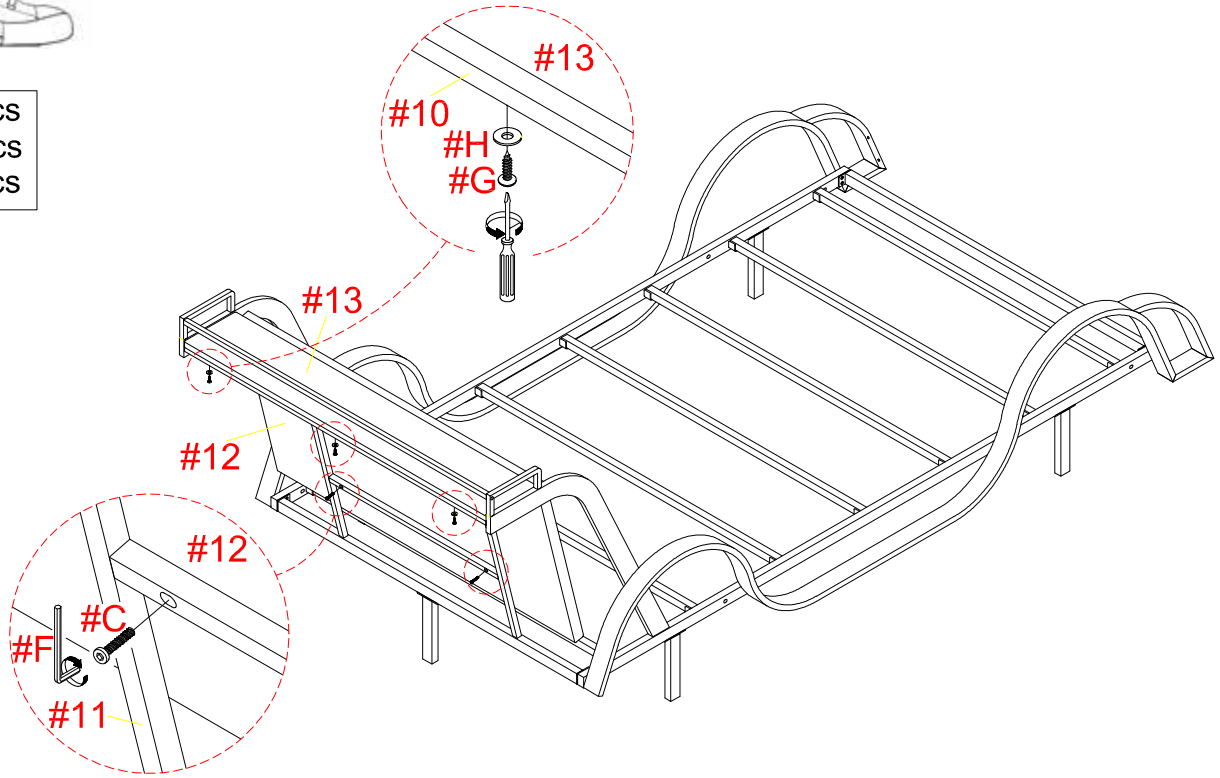

#D x 4pcs

- I. Align the footboard (#6) in between the left/right side rail.
- II. From within, insert 2 bolts (#D) into each side and secure using the Allen wrench (#F).

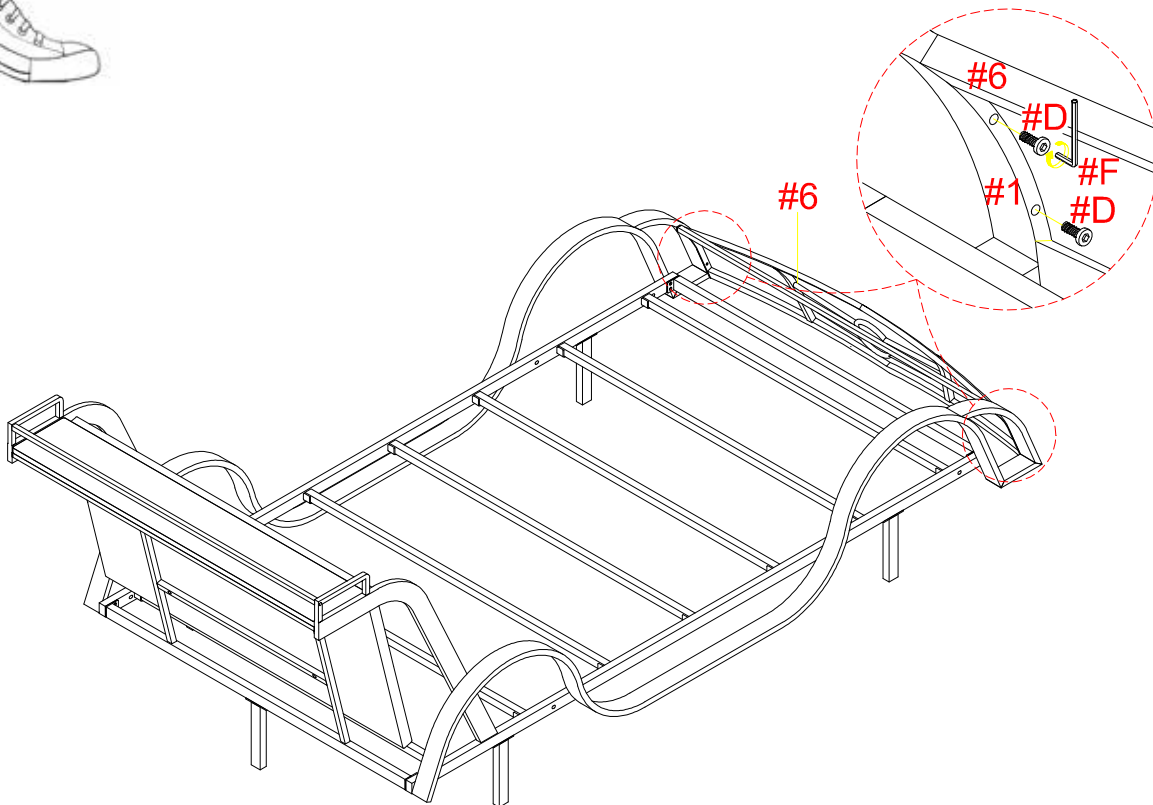



- I. Align the wheels (#15) to the left/right side rails.
- II. On the other side insert 2 bolts (#B) into each wheel and secure using the Allen wrench (#F).

#B x 8pcs

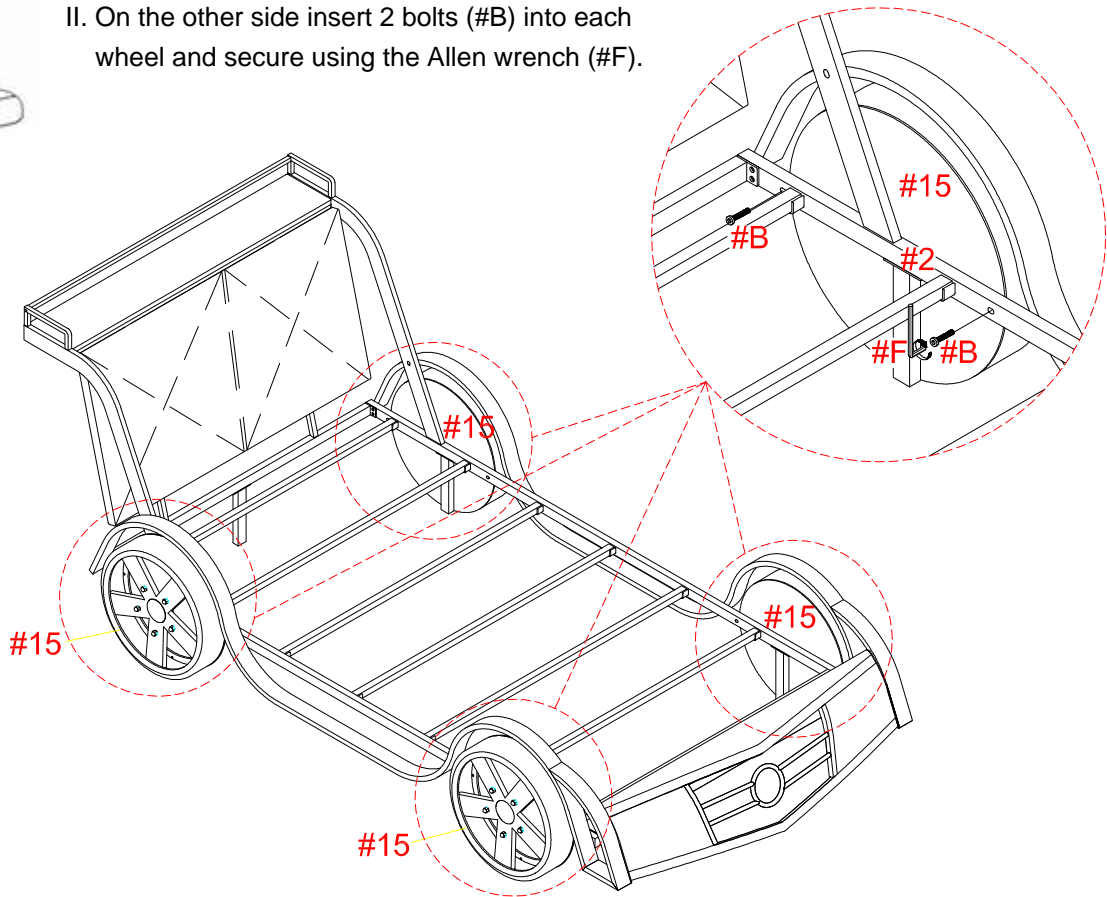

Make sure all bolts are firmly secured.

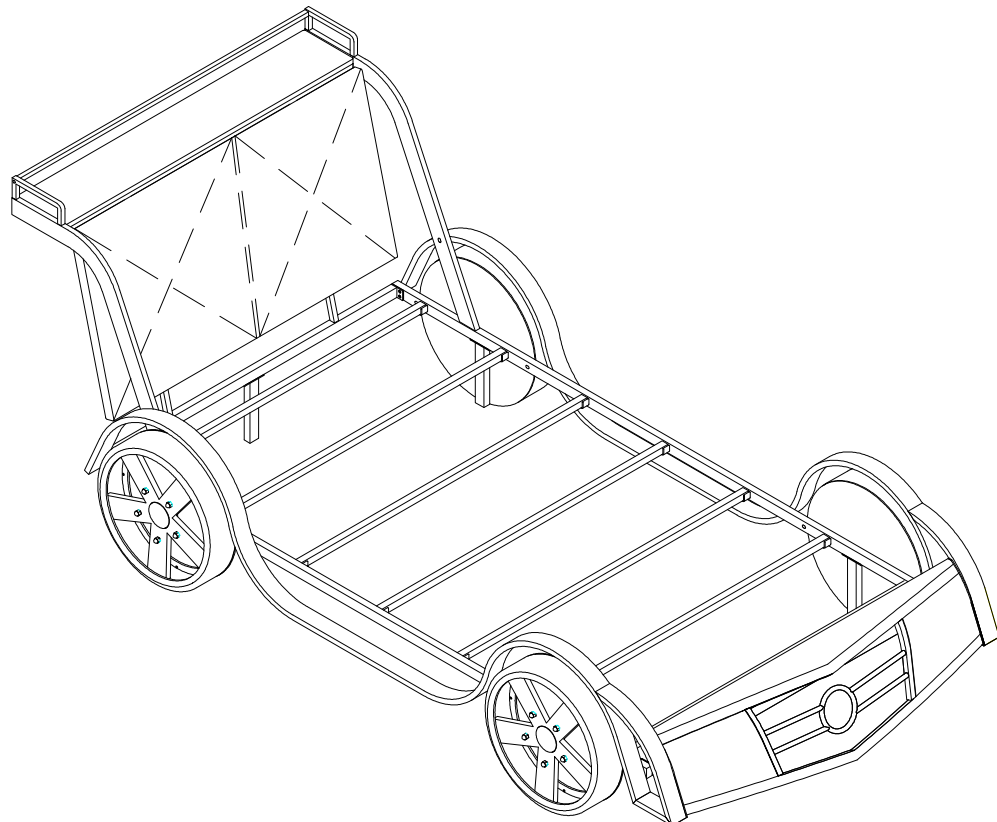

ASSEMBLY IS COMPLETED