

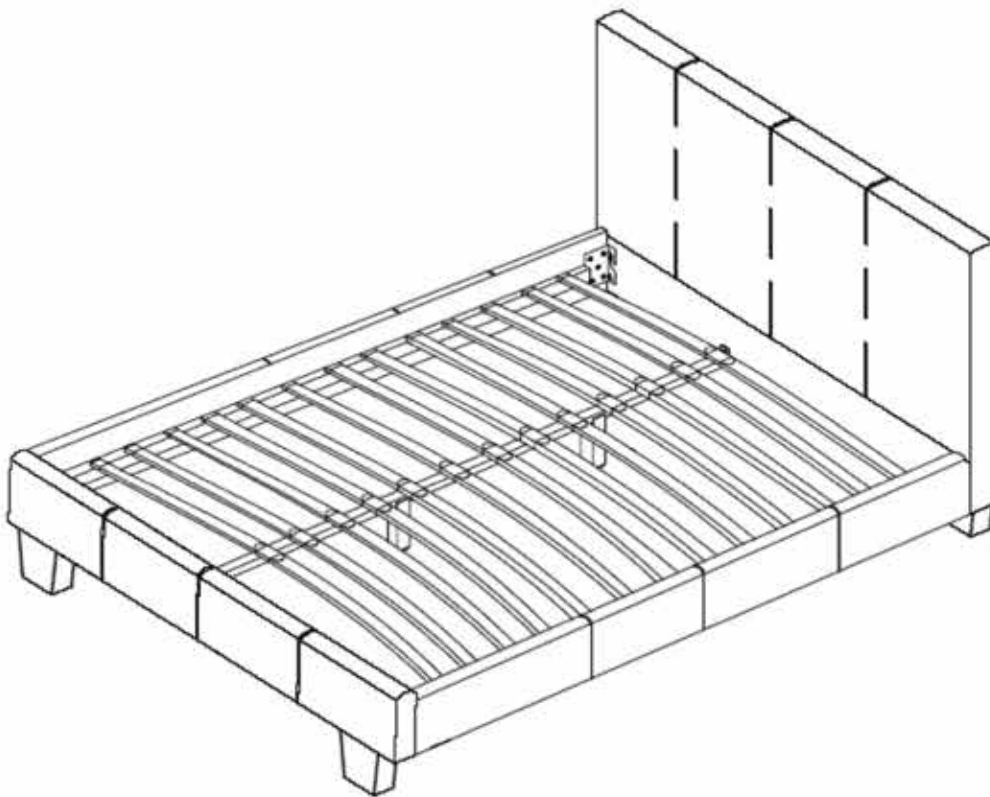

Furniture of America®

Assembly Instructions

CM7793F/Q



ASSEMBLY RATING

The Assembly Rating is a 5-point system that shows the degree of effort needed in assembling a specific product (with 1 being easy and 5 being difficult). For some products, two persons are recommended.

EASY  DIFFICULT

Tools Required for Assembly:

Allen Wrench

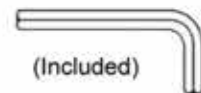

2 PERSONS RECOMMENDED

ASSEMBLY & CARE ADVICE

FOR YOUR FURNITURE TO LAST, CORRECT ASSEMBLY AND PROPER MAINTENANCE ARE NECESSARY. PLEASE FOLLOW THE INFORMATION PROVIDED BELOW TO FULLY ENJOY YOUR FURNITURE.

BASIC ASSEMBLY TECHNIQUES

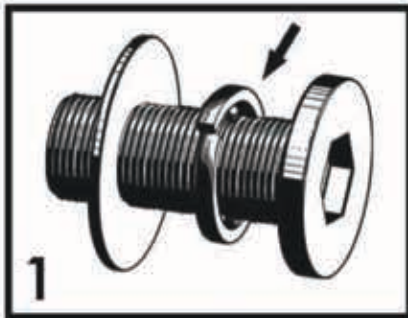

1
When lock or spring washer is used in an assembly, please make sure the lock or spring washer is placed between the larger flat washer and the head of the screw or bolt.



2
Position each part correctly and insert screws or bolts into their respective holes by hand tighten or using the proper hand tool. Only tighten when step is completed or when instructed to do so.



3
Use cardboard or carpet area when assembling furniture to prevent scratches. Make sure the furniture rests on a flat and level surface with each leg evenly touching the floor.

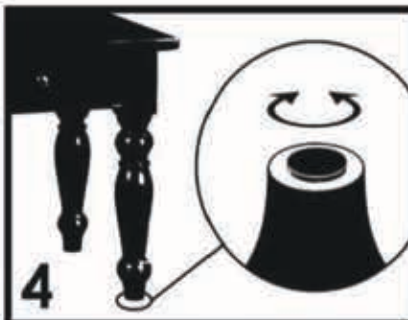

4
Some furniture comes with height adjustment knobs underneath each leg. To lower or to raise each leg, you need to turn clockwise or counterclockwise, respectively.

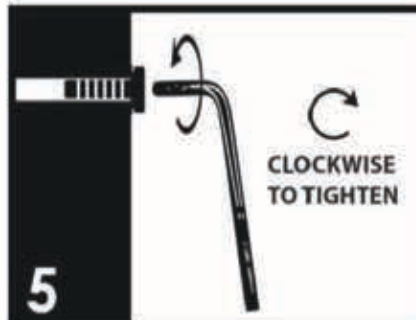

5
Make sure all parts are properly aligned, then use the appropriate hand tool to completely tighten the bolts or screws. Do not use power tools and do not overtighten.



6
Save the instructions and store the Allen wrench or any supplied tool for later maintenance. After two weeks, check and tighten any loose hardware and repeat again every six months thereafter.

IT IS THE USER'S RESPONSIBILITY TO MAINTAIN THE FURNITURE. THE HARDWARE MAY LOOSEN OVER TIME AND MAY CAUSE THE FURNITURE TO BE WOBBLY AND UNABLE TO SUPPORT ITS INTENDED WEIGHT CAPACITY. THIS MAY LEAD TO COLLAPSE AND MAY CAUSE SERIOUS INJURY.



FAILURE TO FOLLOW THE GUIDELINES ABOVE MAY RESULT IN INJURY AND/OR PROPERTY DAMAGE.









Before you begin, please read Page 3 of "Assembly and Care Advice".

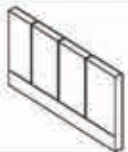



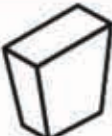



And remember, do not tighten until each step is completed or instructed.

MD

Parts List

	#1 x 1 pc Headboard
	#2 x 2 pcs Side Rail
	#3 x 1 pc Footboard
	#4 x 1 pc Support Rail
	#5 x 4 pcs Foot
	#6 x 26 pcs Slat
	#7 x 2 pcs $\Phi 1/4"$ Support Leg-250x30x20mm

Hardware List

	#A x 8 pcs Bolt 5/16"x1"
	#B x 6 pcs Bolt 5/16"x1-5/8"
	#C x 8 pcs Bolt 5/16"x3-7/8"
	#D x 22 pcs Flat Washer
	#E x 22 pcs Lock Washer
	#F x 13 pcs Center Connector
	#G x 26 pcs End Cap
	#H x 1 pc Allen Wrench



Due to the size and/or weight of this product, it is highly recommended that the assembly should be done near the area of its intended location. Make sure you have enough space to move around during the assembly. ALWAYS have at least two people to help with transporting and assembling the product to avoid any potential injury and/or damage.



- I. Align the two feet (#5) onto the pre-drilled holes on the bottom corners of the headboard (#1).
- II. Prepare 4 bolt assemblies by inserting FIRST the lock washer (#E) onto the bolt (#C) and then the flat washer (#D) onto the SAME bolt (#C), in that order.
- III. Insert the bolt assemblies through the holes of the feet (#5) and secure those bolts using the Allen wrench (#H) to lock them with the headboard (#1).
- IV. Repeat the process above to assemble the remaining two feet (#5) onto the footboard (#3).

#C x 8 pcs
#D x 8 pcs
#E x 8 pcs

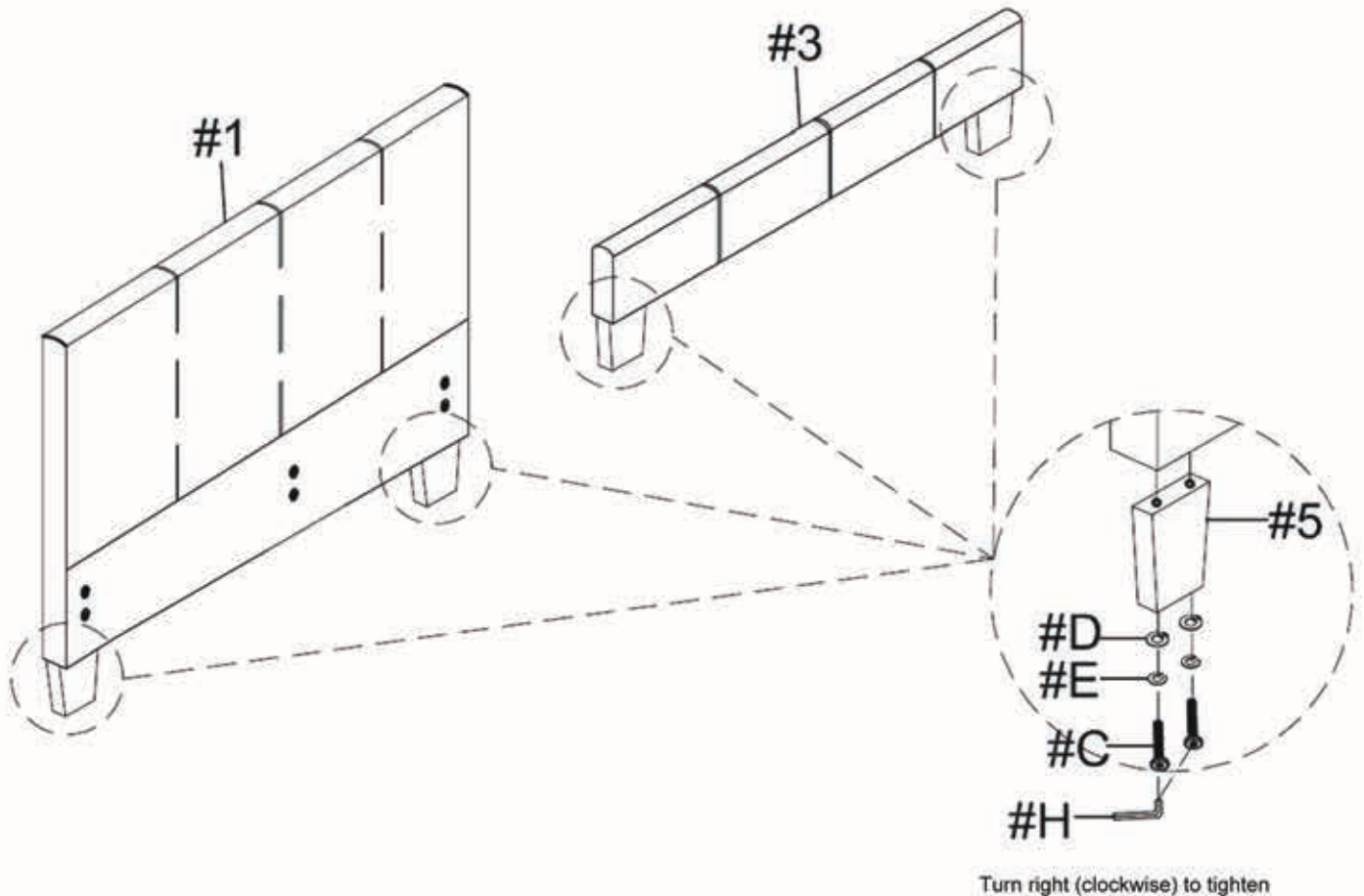



#A x 8 pcs
#D x 8 pcs
#E x 8 pcs

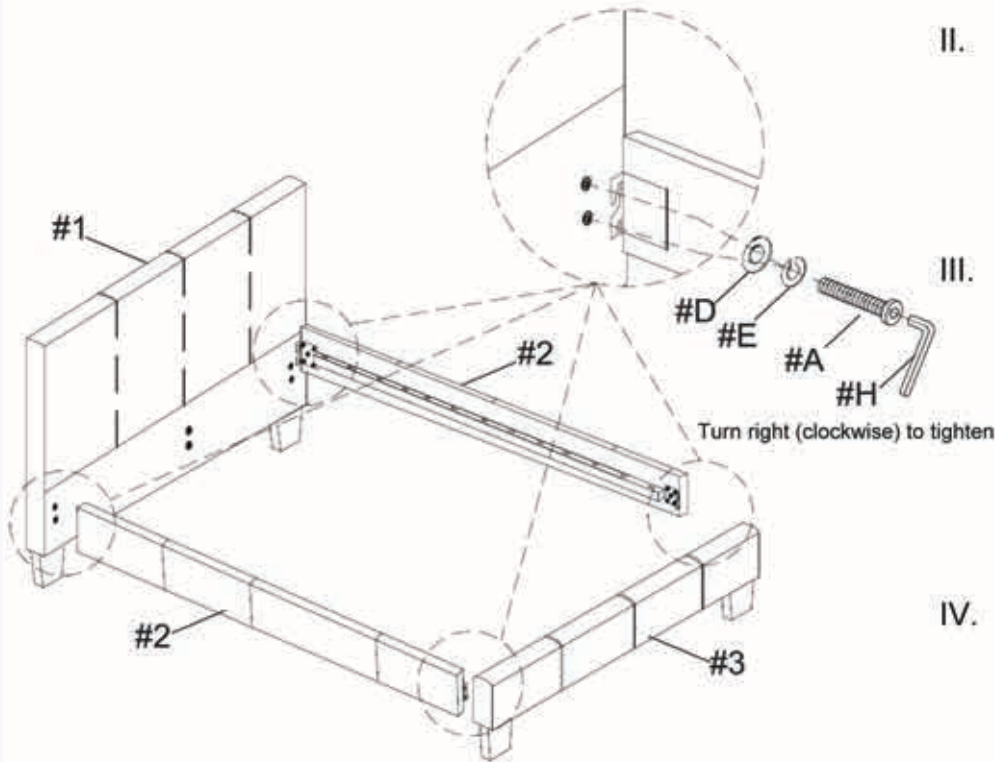

- I. Prepare 4 bolt assemblies by inserting FIRST the lock washer (#E) onto the bolt (#A) and then the flat washer (#D) onto the SAME bolt (#A), in that order.
- II. Insert the bolt assemblies through the right and left side of the pre-drilled holes of the headboard (#1) using the Allen wrench (#H) but expose about 1/2" of the bolts' threads.
- III. Mount the brackets on the side rails (#2) onto the bolts (#A) on each side of the headboard (#1). Make sure all the washers are in the FRONT of the brackets. Use the Allen wrench (#H) to further tighten the bolts to secure the two parts together.
- IV. Repeat the process above to assemble the other ends of the two side rails (#2) onto the footboard (#3).



#B x 2 pcs
#D x 2 pcs
#E x 2 pcs

- I. Align the two slat support legs (#7) with the pre-drilled holes of the support rail (#4).
- II. Prepare 2 bolt assemblies by inserting FIRST the lock washer (#E) onto the bolt (#B) and then the flat washer (#D) onto the SAME bolt (#B), in that order.
- III. Insert the two bolt assemblies through the pre-drilled holes of the support rail (#4) using the Allen wrench (#H) to lock them with the slat support legs (#7).

Adjust the leveler on the slat support legs (#7) according to the ground level on Step 4.

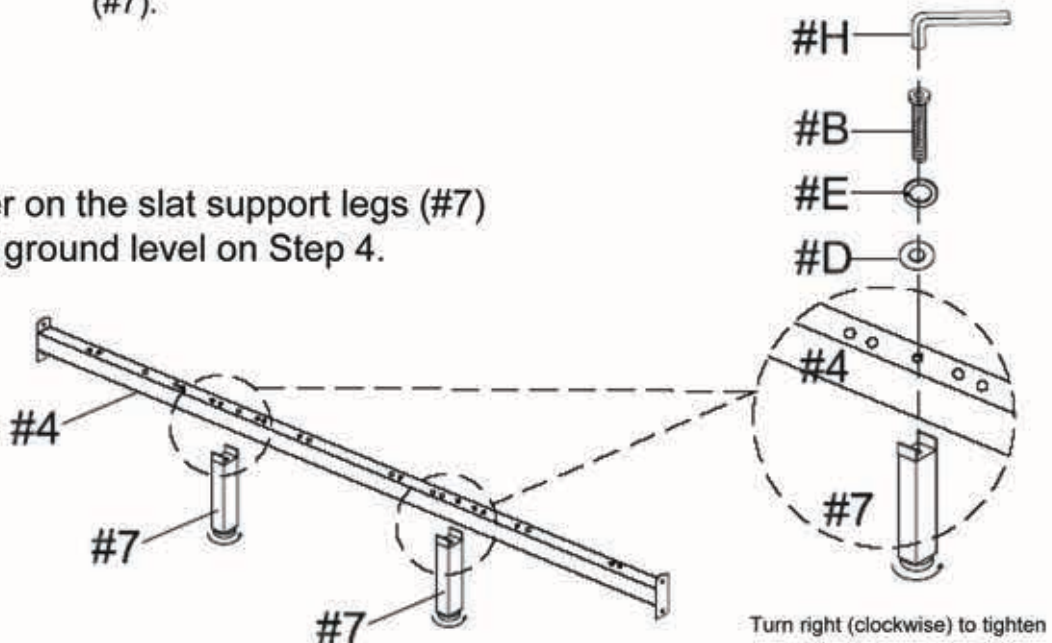



#B x 4 pcs
 #D x 4 pcs
 #E x 4 pcs

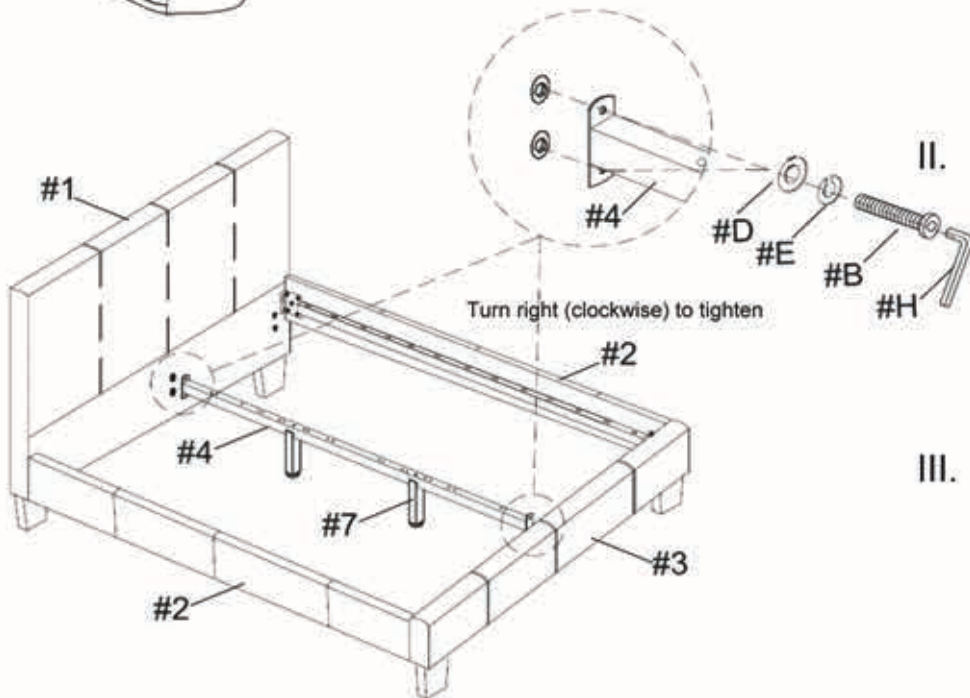

- I. Align the assembled support rail (#4) with the pre-drilled holes on the center of the headboard (#1) and the footboard (#3).
- II. Prepare 4 bolt assemblies by inserting FIRST the lock washer (#E) onto the bolt (#B) and then the flat washer (#D) onto the SAME bolt (#B), in that order.
- III. Insert the 4 bolt assemblies through the brackets of the support rail (#4) using the Allen wrench (#H) to lock them with the headboard (#1) and the footboard (#3).

Adjust the leveler according to the ground level. To lower or to raise the slat support leg, turn the leveler clockwise or counterclockwise, respectively.



Note: The correct position of the bed slats should be arcing UPWARD when placing on the rails.

#F x 13 pcs
 #G x 26 pcs

- I. Prepare a complete bed slat by inserting one center plastic connector (#F) onto the two slats (#6). Then insert two end caps (#G) onto the opposite ends of the same slats (#6).
- II. Align the end caps (#G) on a completed bed slat with the pre-drilled holes on each side of the side rails (#2) and snap down both end caps (#G) into place. Then snap down the center plastic connector (#F) into the support rail (#4).
- III. Repeat the above process to assemble the remaining bed slats.

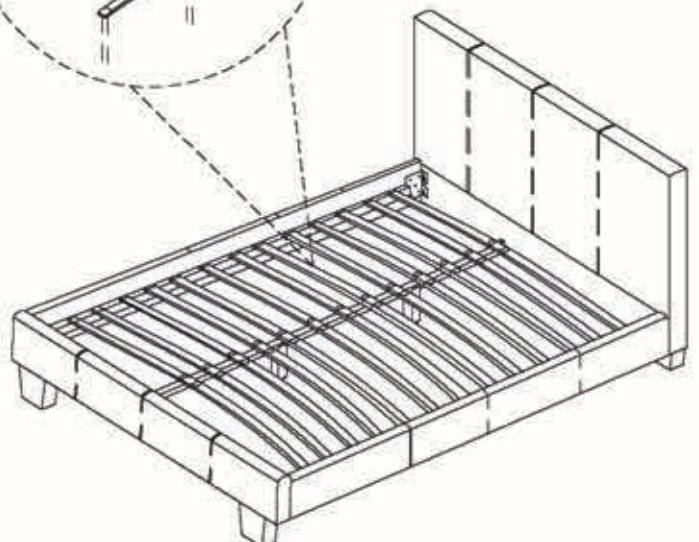
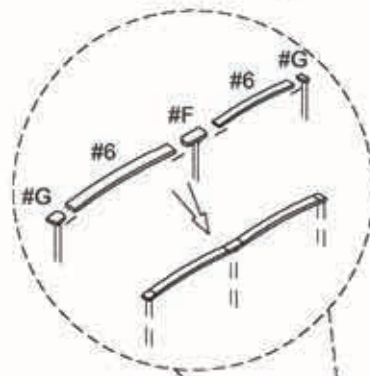

ASSEMBLY IS COMPLETED



Assembly Instructions

CM7793CK/EK

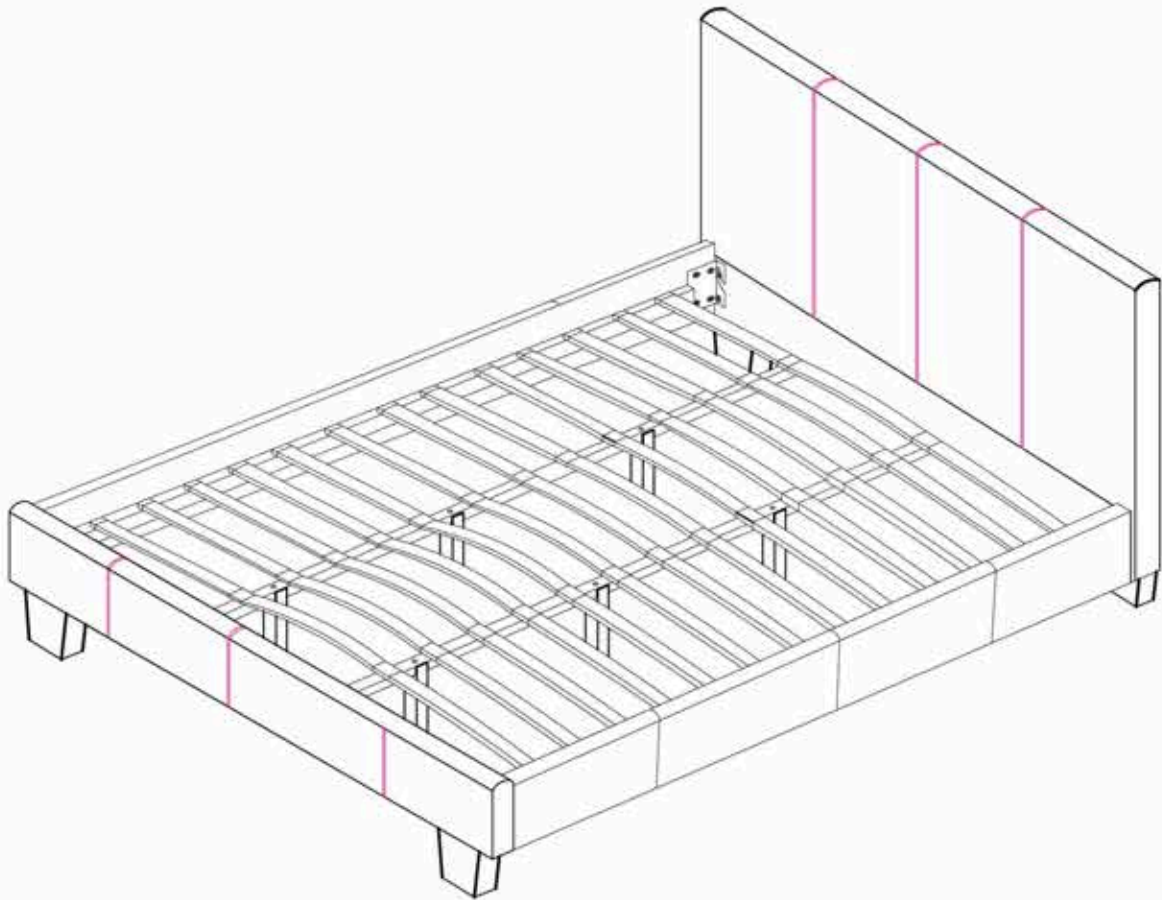

ASSEMBLY RATING

The Assembly Rating is a 5-point system that shows the degree of effort needed in assembling a specific product (with 1 being easy and 5 being difficult). For some products, two persons are recommended.

EASY  DIFFICULT

Tools Required For Assembly:

Allen Wrench

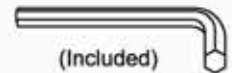

2 PERSONS RECOMMENDED

ASSEMBLY & CARE ADVICE

FOR YOUR FURNITURE TO LAST, CORRECT ASSEMBLY AND PROPER MAINTENANCE ARE NECESSARY. PLEASE FOLLOW THE INFORMATION PROVIDED BELOW TO FULLY ENJOY YOUR FURNITURE.

BASIC ASSEMBLY TECHNIQUES

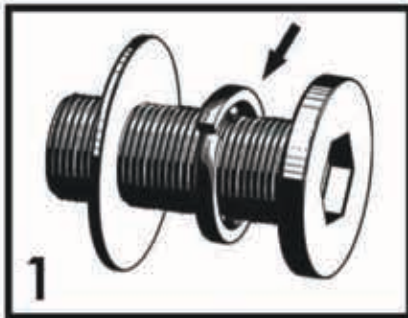

When lock or spring washer is used in an assembly, please make sure the lock or spring washer is placed between the larger flat washer and the head of the screw or bolt.



Position each part correctly and insert screws or bolts into their respective holes by hand tighten or using the proper hand tool. Only tighten when step is completed or when instructed to do so.



Use cardboard or carpet area when assembling furniture to prevent scratches. Make sure the furniture rests on a flat and level surface with each leg evenly touching the floor.



Some furniture comes with height adjustment knobs underneath each leg. To lower or to raise each leg, you need to turn clockwise or counterclockwise, respectively.

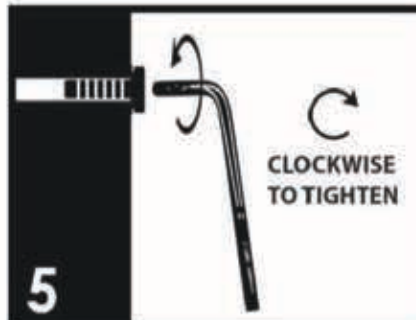

Make sure all parts are properly aligned, then use the appropriate hand tool to completely tighten the bolts or screws. Do not use power tools and do not overtighten.



Save the instructions and store the Allen wrench or any supplied tool for later maintenance. After two weeks, check and tighten any loose hardware and repeat again every six months thereafter.

IT IS THE USER'S RESPONSIBILITY TO MAINTAIN THE FURNITURE. THE HARDWARE MAY LOOSEN OVER TIME AND MAY CAUSE THE FURNITURE TO BE WOBBLY AND UNABLE TO SUPPORT ITS INTENDED WEIGHT CAPACITY. THIS MAY LEAD TO COLLAPSE AND MAY CAUSE SERIOUS INJURY.









FAILURE TO FOLLOW THE GUIDELINES ABOVE MAY RESULT IN INJURY AND/OR PROPERTY DAMAGE.



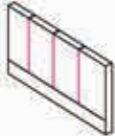

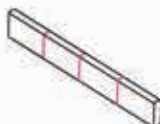





Before you begin, please read Page 2 of "Assembly and Care Advice".

And remember, do not tighten until each step is completed or instructed.

Parts List

	#1 x 1pc Headboard
	#2 x 2pcs Side Rail
	#3 x 1pc Footboard
	#4 x 2pcs Support Rail
	#5 x 4pcs HB/FB Foot
	#6 x 39pcs Slat
	#7 x 6pcs $\Phi 1/4$ " Support Leg-250x30x20mm

Hardware List

	#A x 8pcs BOLT 5/16"X1"
	#B x 14pcs BOLT 5/16"X1-1/2"
	#C x 8pcs BOLT 5/16"X4"
	#D x 30pcs Lock Washer
	#E x 30pcs Flat Washer
	#F x 26pcs Center Connector
	#G x 26pcs End Cap
	#H x 1pc Allen Wrench M5



- #Cx 8pcs
- #Dx 8pcs
- #Ex 8pcs

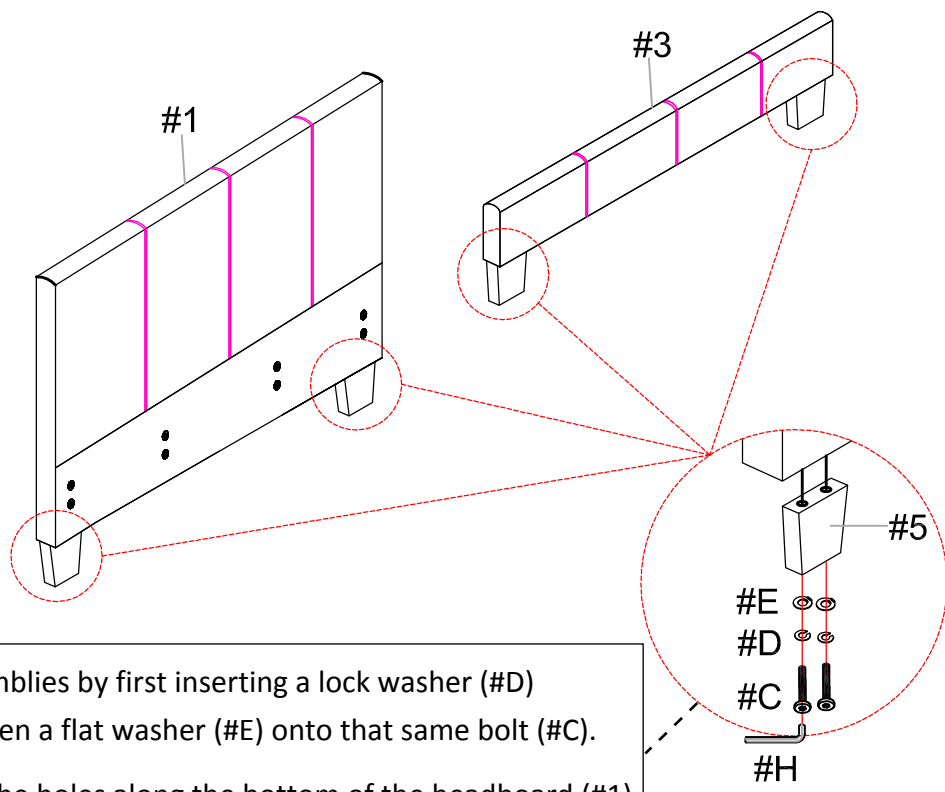

1. Prepare 8 bolt assemblies by first inserting a lock washer (#D) onto the bolt (#C) then a flat washer (#E) onto that same bolt (#C).
2. Align a foot (#5) to the holes along the bottom of the headboard (#1) and footboard (#3). Insert 2 bolt assemblies into each and secure.



- #Ax 8pcs
- #Dx 8pcs
- #Ex 8pcs

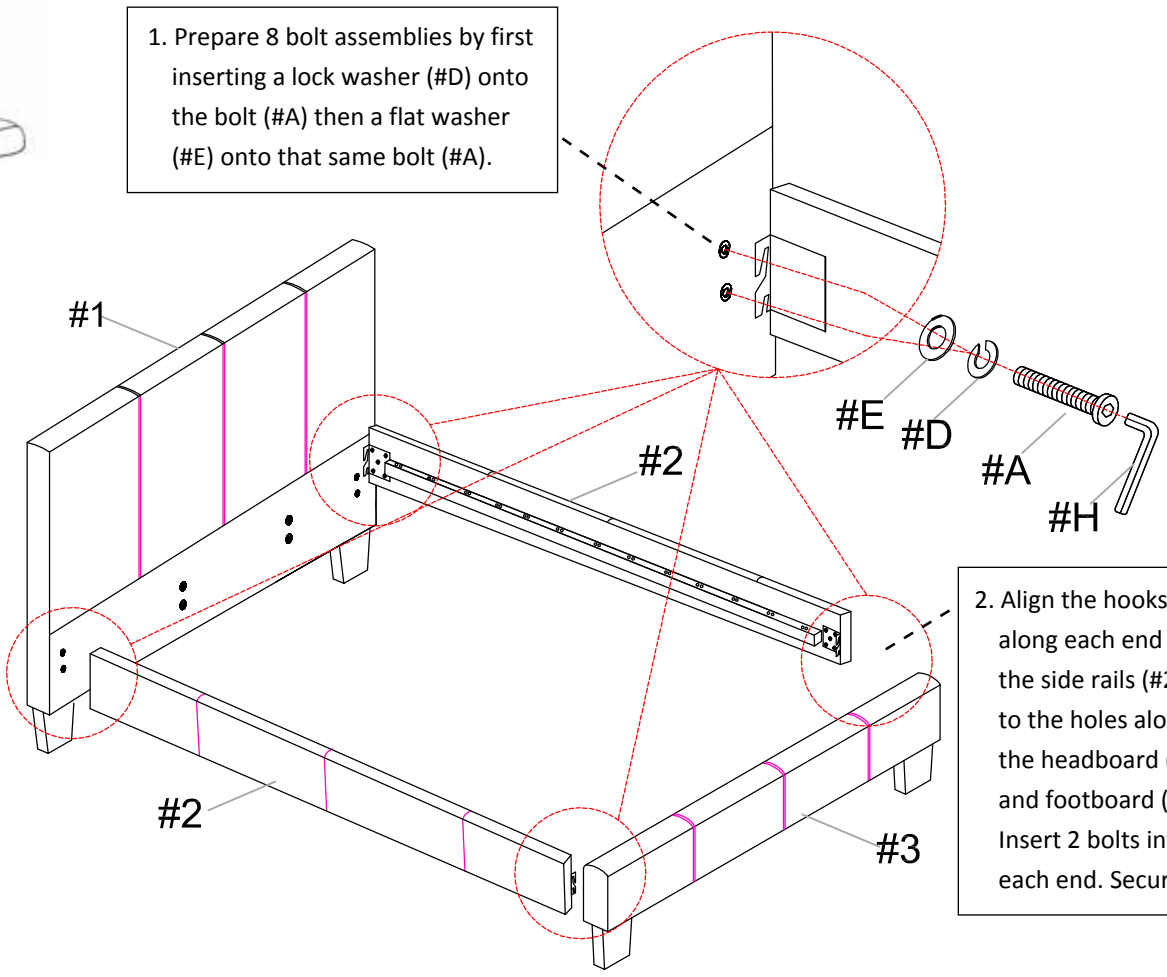

1. Prepare 8 bolt assemblies by first inserting a lock washer (#D) onto the bolt (#A) then a flat washer (#E) onto that same bolt (#A).

2. Align the hooks along each end of the side rails (#2) to the holes along the headboard (#1) and footboard (#3). Insert 2 bolts into each end. Secure.



#3

#B x 6pcs
#D x 6pcs
#E x 6pcs

1. Prepare 8 bolt assemblies by first inserting a lock washer (#D) onto the bolt (#B) then a flat washer (#E) onto that same bolt (#B).

2. Align the support rail legs (#7) to the holes along the support rail (#4), then insert a bolt assembly into each from above. Secure using the Allen wrench.

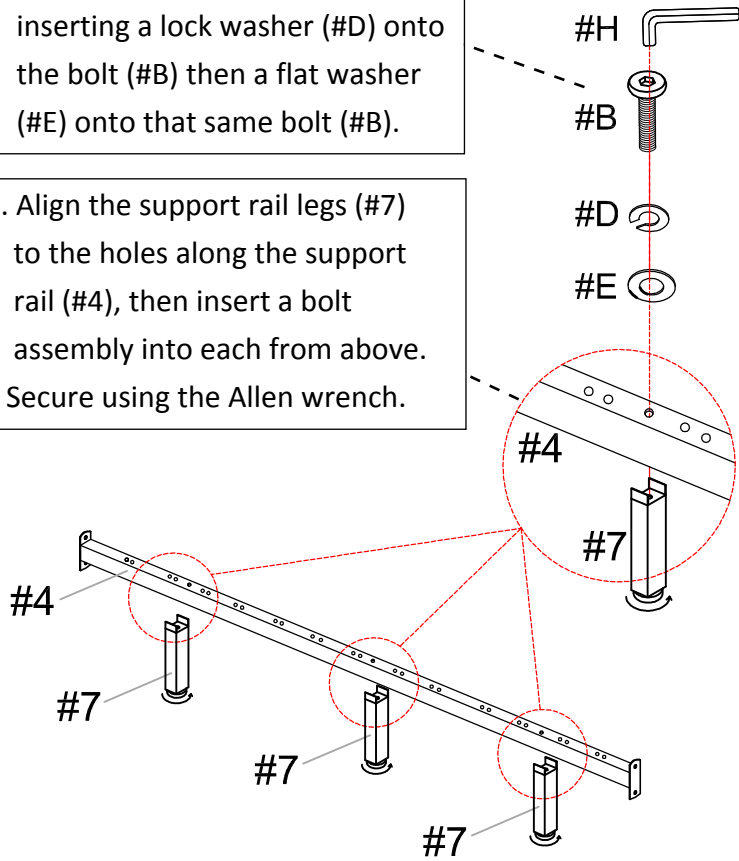

X2



#4

#B x 8pcs
#D x 8pcs
#E x 8pcs

1. Prepare 8 bolt assemblies by first inserting a lock washer (#D) onto the bolt (#B) then a flat washer (#E) onto that same bolt (#B).

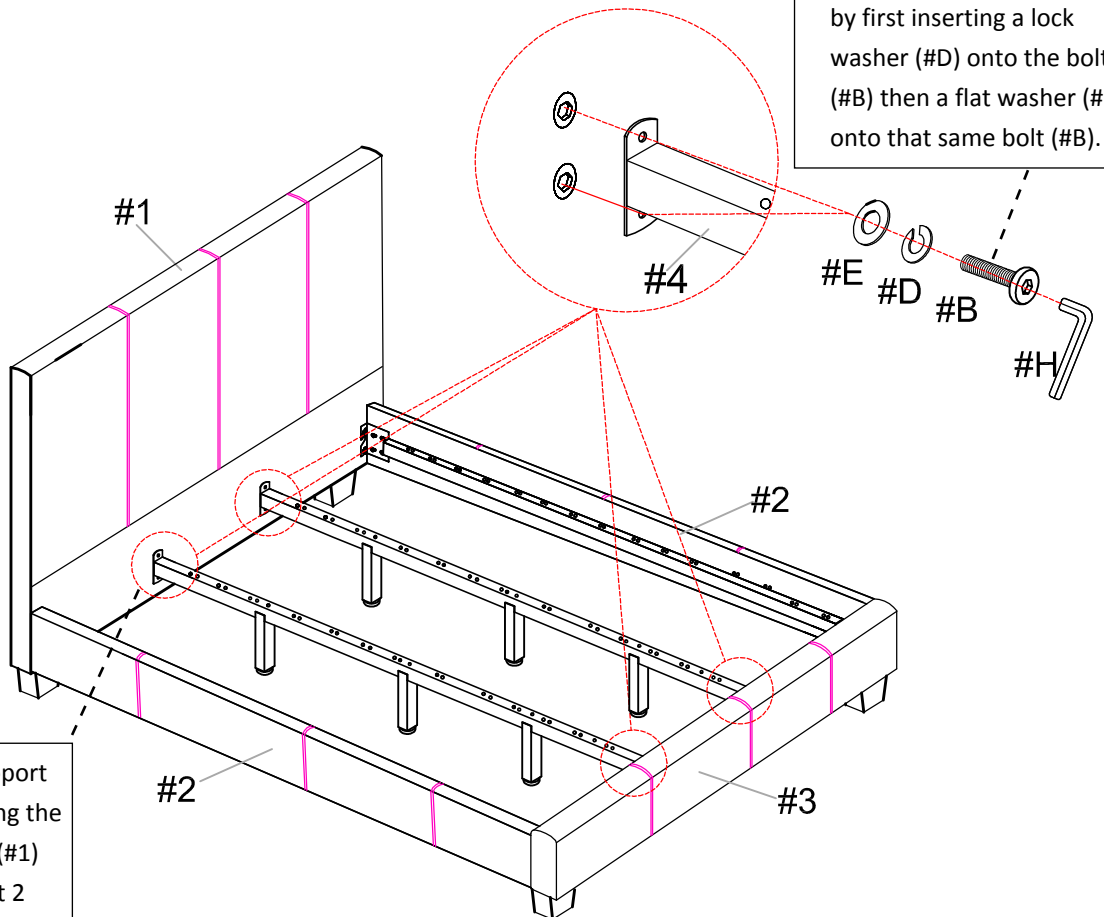

2. Align each end of the support rails (#4) to the holes along the center of the headboard (#1) and footboard (#3). Insert 2 bolts into each end. Secure.



#F x 26pcs
#G x 26pcs

1. Prepare 13 complete slats by inserting (refer to the image below):
end cap (#G) > slat (#6) > Center connector (#F) > slat (#6) > center connector (#F) > end cap (#G)

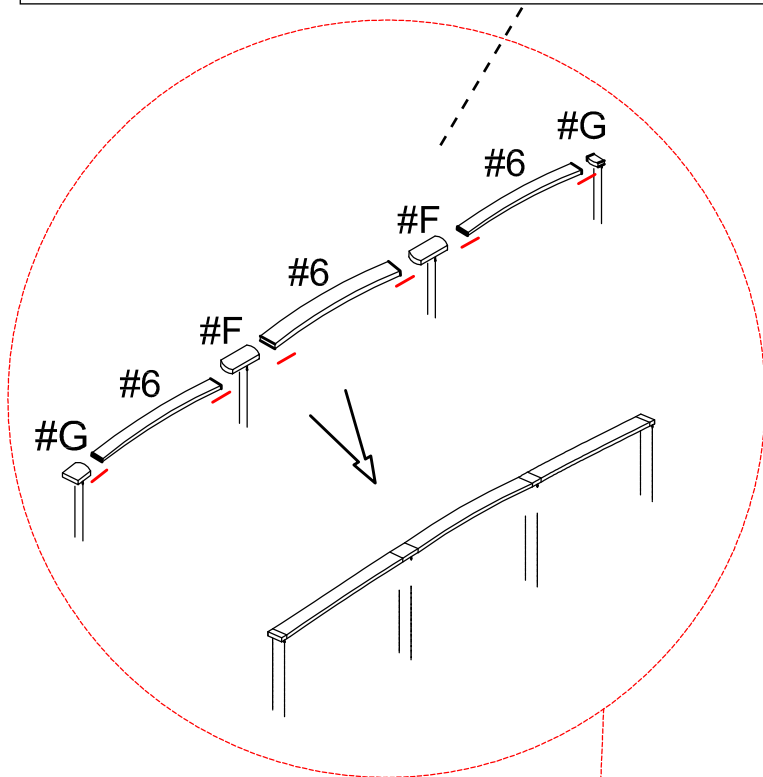

Note: Curved side should face up.

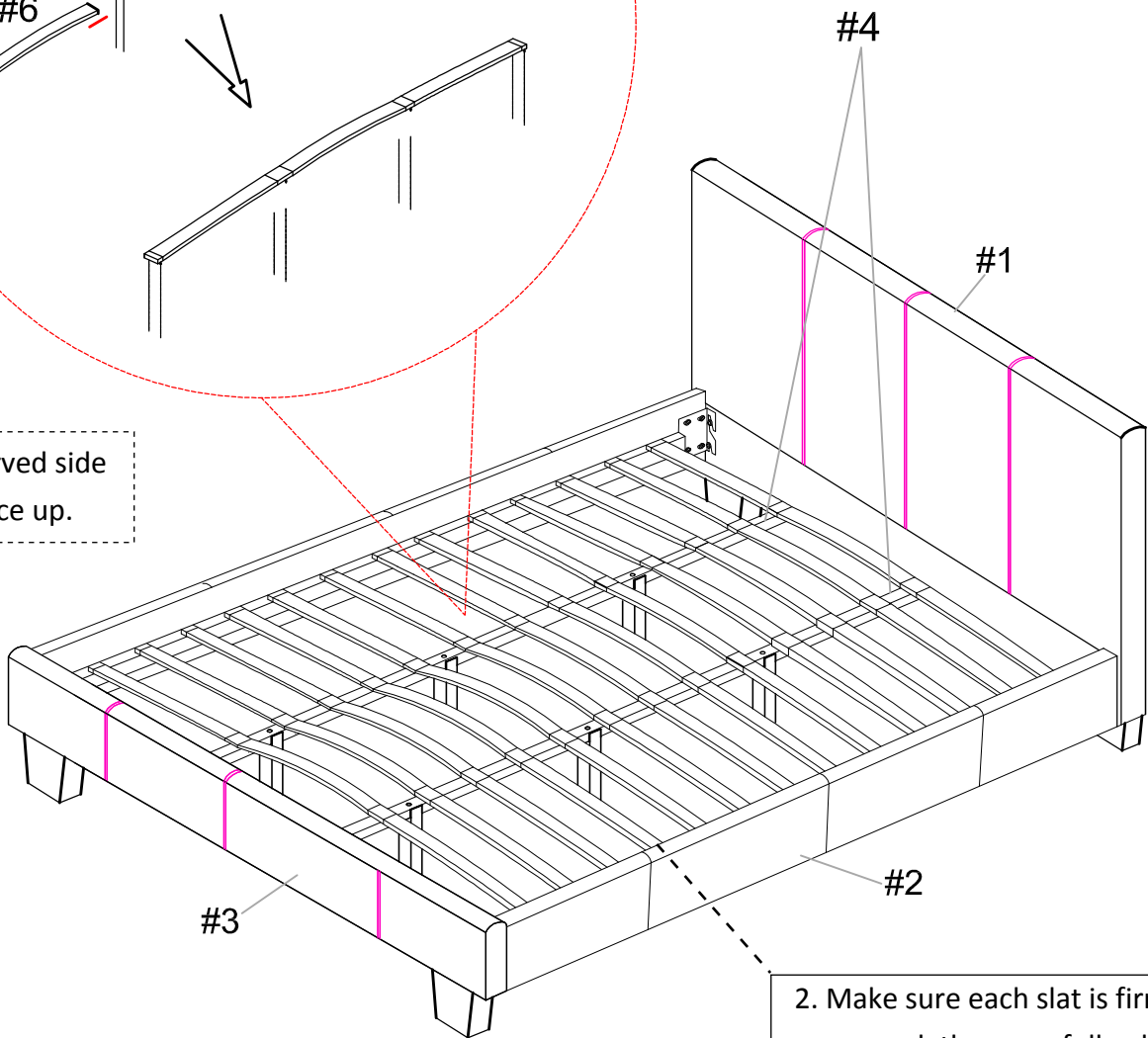

2. Make sure each slat is firmly secured, then carefully place each slat onto the rails.

ASSEMBLY IS COMPLETED