

ASSEMBLY INSTRUCTIONS

MODEL #

CM7751EK

Questions?

GIVE US CALL: 1-888-980-5122
MON-FRI 8:30AM - 5:30PM (PST)

TOOLS REQUIRED



Allen Wrench

(Included)



Phillips
Screwdriver

(Not Included)



3 - People
Recommended

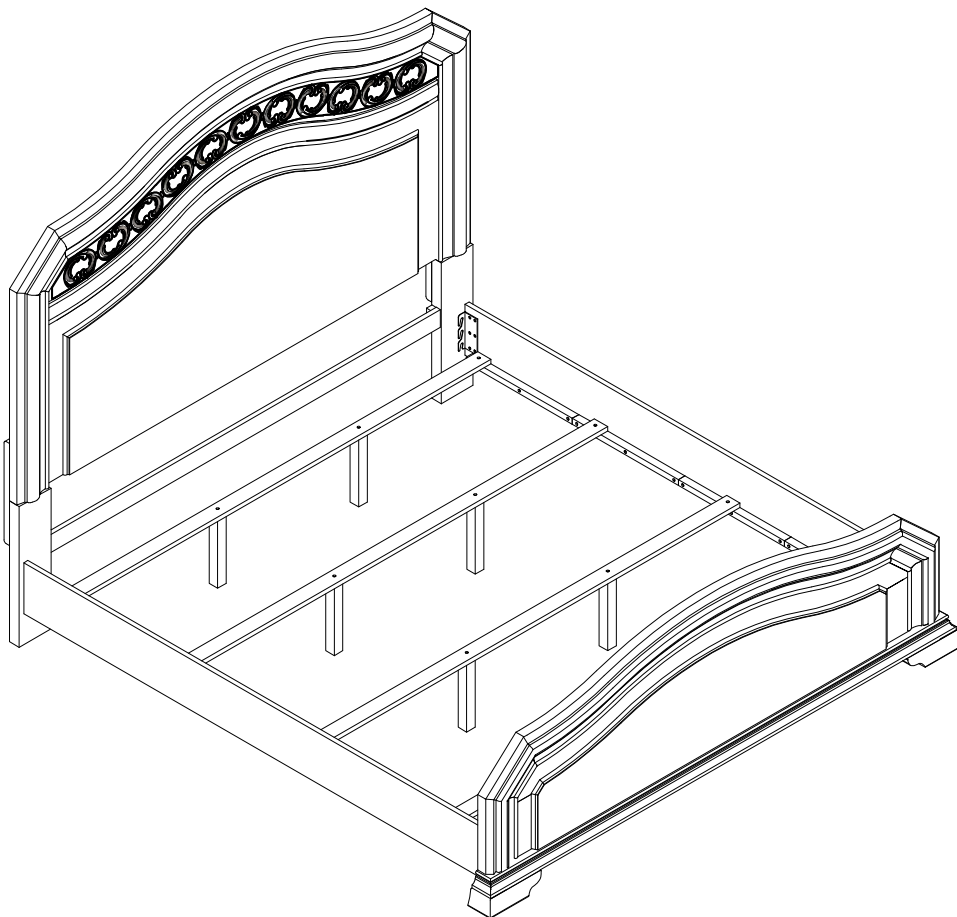

ASSEMBLY RATING



EASY —————> DIFFICULT

The Assembly Rating is a 5-point system showing the level of effort needed to assemble a specific product.



FOA Intro

Thank you for your purchase!

We hope you enjoy this new addition to your home for many years to come.

Our commitment to providing quality products does not simply end when you purchase our product. We fully stand behind our products from start to finish. Our customer service department is available Monday – Friday 8:30 AM – 5:30 PM Pacific and can help with assembly questions as well as, if necessary, replacing damaged or missing parts. To help expedite our service, please have these assembly instructions readily available, along with your order receipt.

 **Consumer Hotline**
Toll-Free 1-888-980-5122

 **WEBSITE**
www.foagroup.com

    foagroup

 **Monday to Friday**
8:30AM- 5:30PM (PST)

 **E-MAIL**
cs.ec@foagroup.com

 FurnitureOfAmerica

CHECK BEFORE STARTING

Are you missing anything?

Double-check all parts, hardware and accessories listed on Page 6 are accounted for.

Should we send any replacements?

Are there any irregularities or flaws in the parts? We can send replacements!

Check out our Quick Tips!

We recommend reviewing the pre-assembly handouts. Even experts need a refresher now and then!

Prep Time!

Please review the assembly instructions and all diagrams prior to assembling. Arrange parts as recommended on Page 7 and group identical hardware together to make assembling easier.

PRE ASSEMBLY INTRODUCTION

We understand building ready-to-assemble furniture can be a challenging experience for some. To help avoid confusion, we have provided some helpful tips that may speed up the process.



Teamwork

ALWAYS have at least two people to help with transporting and assembling the product to avoid potential injury and/or damage.

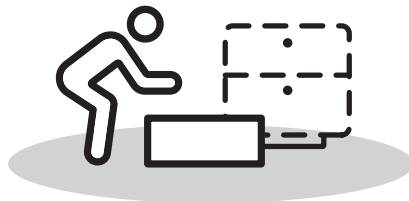
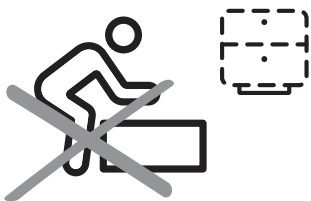

Suitable Location

Assembling near the area of the intended location is highly recommended.



Sufficient Space

Make sure you have enough space to move around during the assembly.



Avoid Scratches

Use cardboard, blankets or a carpeted area while assembling furniture to prevent scratches.

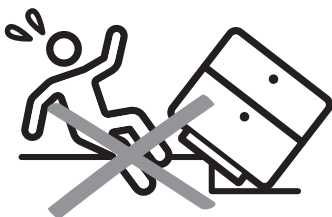

Flat Surface

Make sure the furniture rests on a flat and level surface with each leg evenly touching the floor.

ASSEMBLY AND CARE ADVICE



FAILURE TO FOLLOW THE GUIDELINES BELOW MAY RESULT IN INJURY AND/OR PROPERTY DAMAGE.



Position each part correctly and insert screws or bolts into their respective holes.

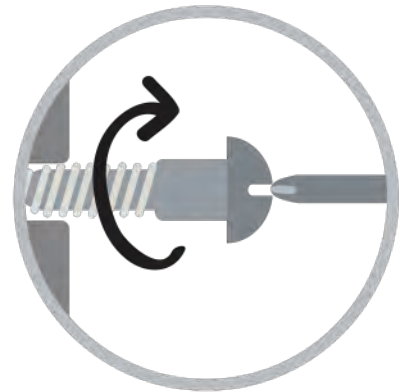

Turn clockwise to tighten and only tighten when step is completed or when instructed to do so.



Use the appropriate hand tools or power tools for assembly. Select steps, such as tightening screws and/or bolts, may require hand tools to avoid causing damage during assembly.



Save the instructions and store any supplied tools for later maintenance.

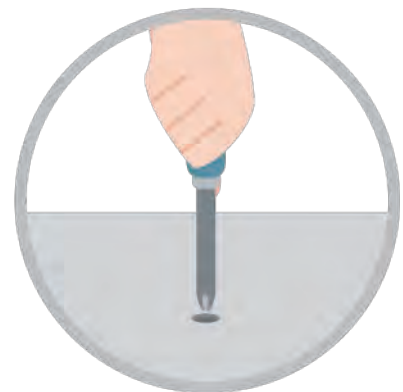

After two weeks, check and tighten any loose hardware and repeat again every six months thereafter.

IT IS THE USER'S RESPONSIBILITY TO MAINTAIN THE FURNITURE. THE HARDWARE MAY LOOSEN OVER TIME AND MAY CAUSE THE FURNITURE TO BE WOBBLY AND UNABLE TO SUPPORT ITS INTENDED WEIGHT CAPACITY. THIS MAY LEAD TO COLLAPSE AND MAY CAUSE SERIOUS INJURY.

BED

CM7751EK



- Please keep instructions for future reference.
- Check the quantity and irregularity of parts and hardware before you start.

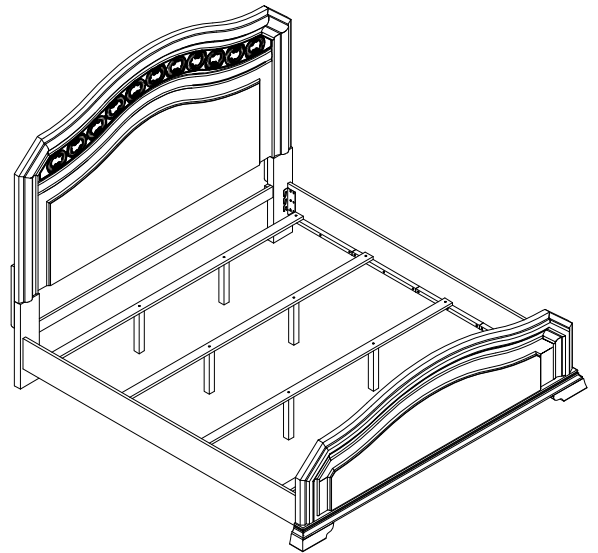

PARTS

#1 1pc

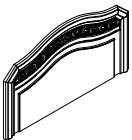

Headboard

#2 2pcs

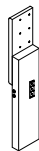

Headboard Leg(L&R)

#3 1pc

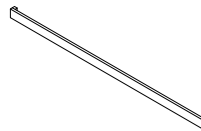

Headboard Bottom Rail

#4 1pc

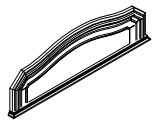

Footboard

#5 2pcs

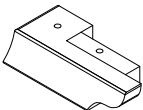

Footboard Leg(L&R)

#6 2pcs

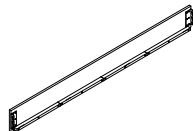

Side rail

#7 8pcs

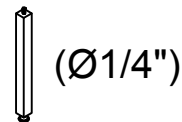

Slat support leg

#8 4pcs

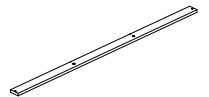

Slat

HARDWARE

#A 16pcs



Bolt Ø1/4" x 1-3/4"

#B 20pcs



Lock Washer Ø1/4"

#C 20pcs



Flat Washer Ø1/4"

#D 3pcs



Allen Wrench M4

#E 8pcs



Screw M4 x 30mm

#F 4pcs













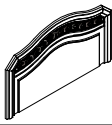

Bolt Ø1/4" x 2"

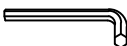
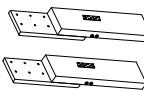
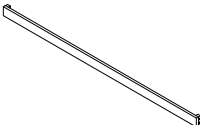
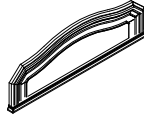
#G 12pcs

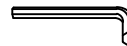

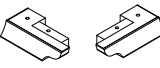
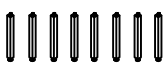
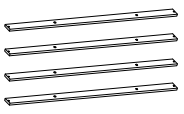
Bolt Ø5/16" x 1"

CM7751EK is packed in 3 cases

Carton	Disignation	Part	Hardware
CM7751EK-HB	Headboard	#1 	 #A x 16pcs  #B x 16pcs  #C x 16pcs  #D x 1pc
	Headboard Leg(L&R)	#2 	
	Headboard Bottom Rail	#3 	
CM7751EK-FB	Footboard	#4 	 #B x 4pcs  #C x 4pcs  #D x 1pc  #E x 8pcs  #F x 4pcs
	Footboard Leg(L&R)	#5 	
	Slat support leg	#7 	
	Slat	#8 	
CM7751EK-R	Side rail	#6 	 #D x 1pc  #G x 12pcs

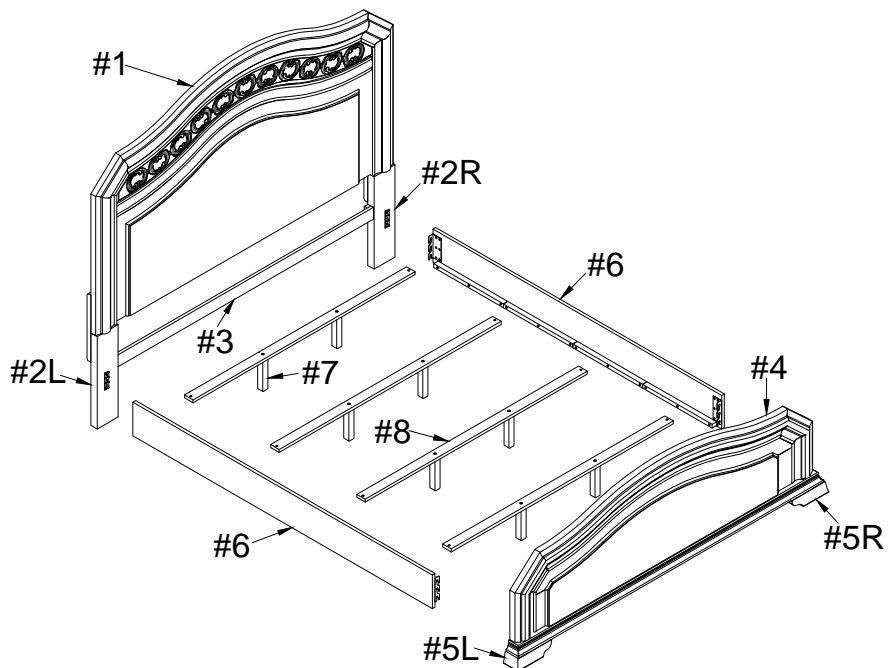

ASSEMBLY INSTRUCTIONS

1

Part #1 x1pc

Part #2 x2pcs

Hardware #A x12 pcs

Hardware #B x12 pcs

Hardware #C x12 pcs

Prepare 12 bolts assembly by inserting lock washer (#B), then flat washer (#C) onto bolts (#A). Align HB legs (#2R/L) to the holes of the headboard (#1). Secure by using bolts (#A).

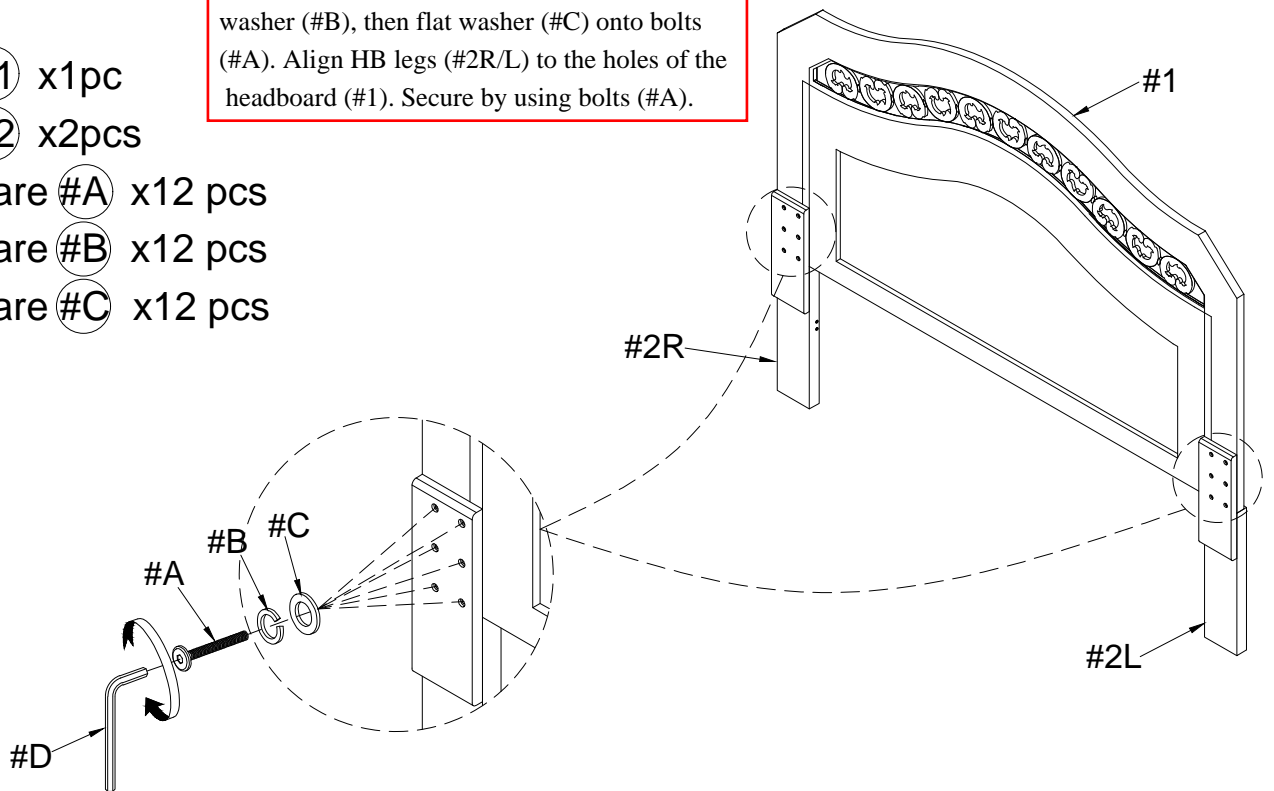

2

Part #3 x1pc

Hardware #A x4 pcs

Hardware #B x4 pcs

Hardware #C x4 pcs

Prepare 4 bolts assembly by inserting lock washer (#B), then flat washer (#C) onto bolts (#A). Align headboard support (#3) to the holes of the headboard legs (#2R/L), then secure by using bolts (#A).

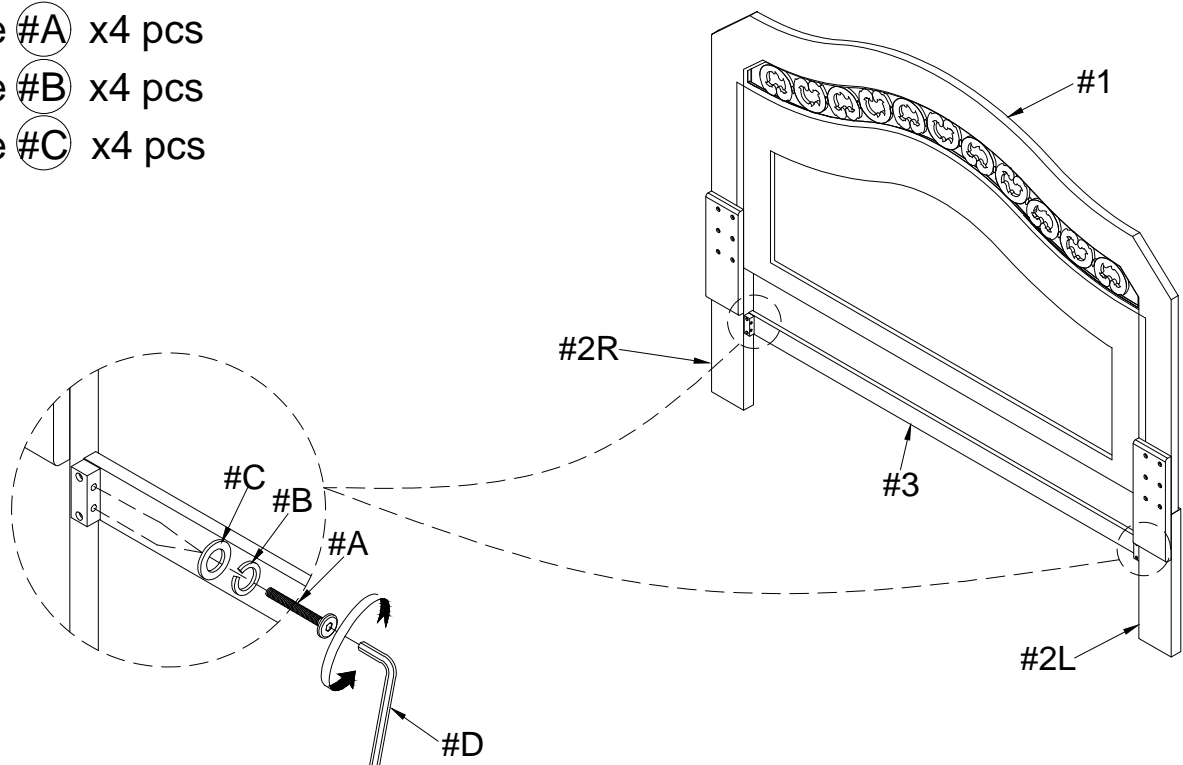

ASSEMBLY INSTRUCTIONS

3

Part #4 x1pc

Part #5 x2pcs

Hardware #B x4 pcs

Hardware #C x4 pcs

Hardware #F x4 pcs

Prepare 4 bolts assembly by inserting lock washer (#B), then flat washer (#C) onto bolts (#F).
Align legs (#5R/L) to the holes of the footboard (#4). Secure by using bolts (#F).

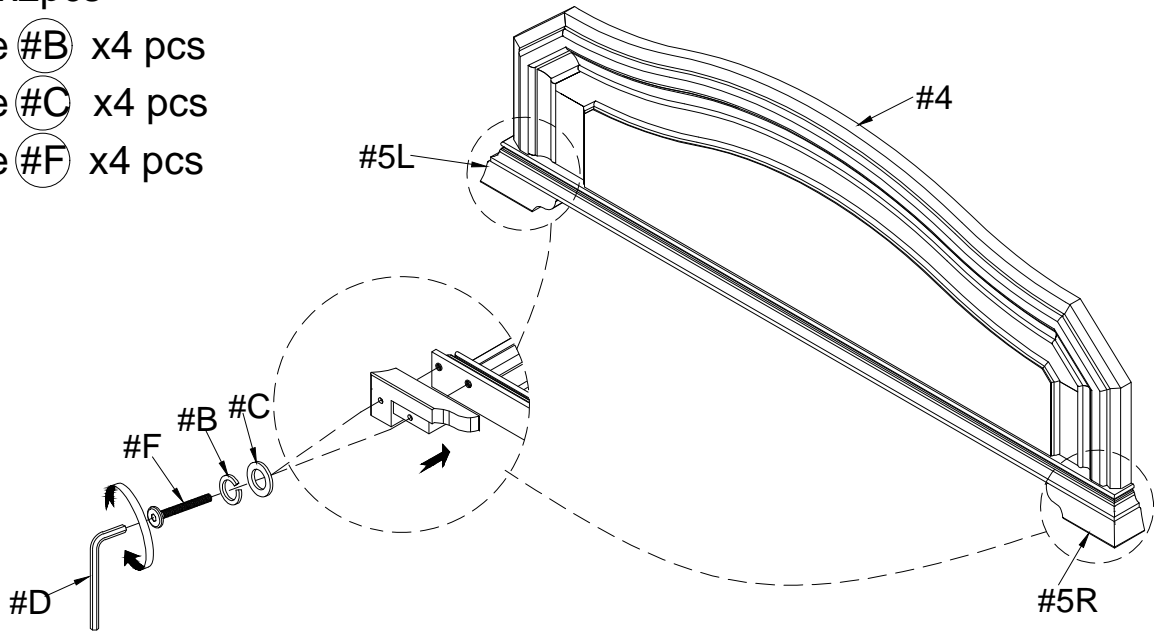

4

Part #6 x2pcs

Hardware #G x12 pcs

Attach bolts (#G) half way into the holes of the headboard (#1) and footboard (#4).
Align and hook side rails (#6) to the bolts (#G). Secure by tightening bolts (#G).

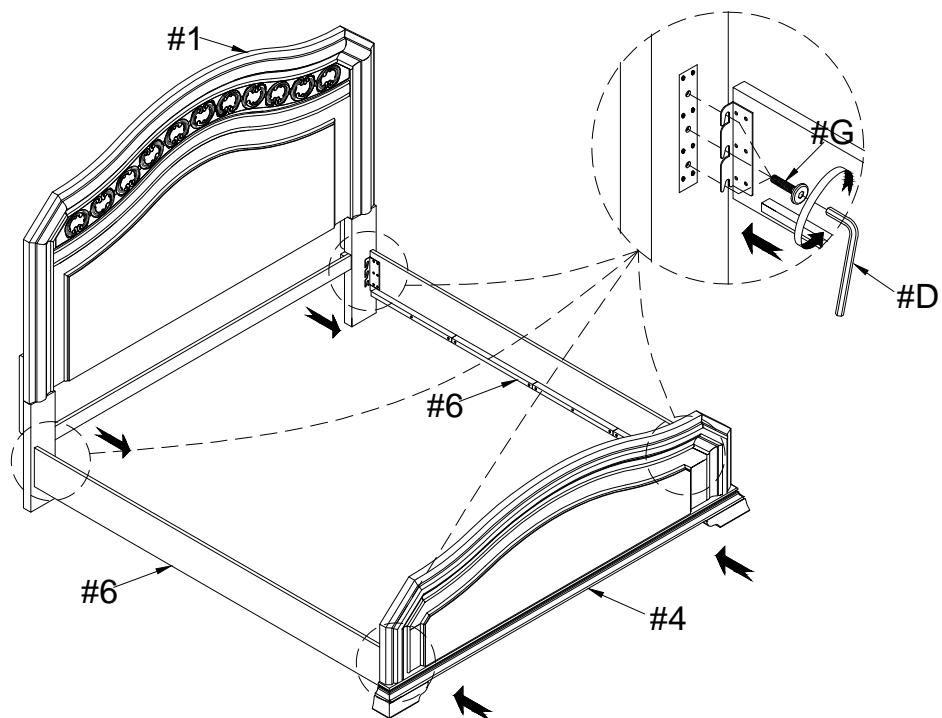

ASSEMBLY INSTRUCTIONS

5

Part #7 x8pcs

Part #8 x4pcs

Attach support legs (#7) to the holes of the slats (#8), then adjust the leveler on the support legs (#7) according to ground level.

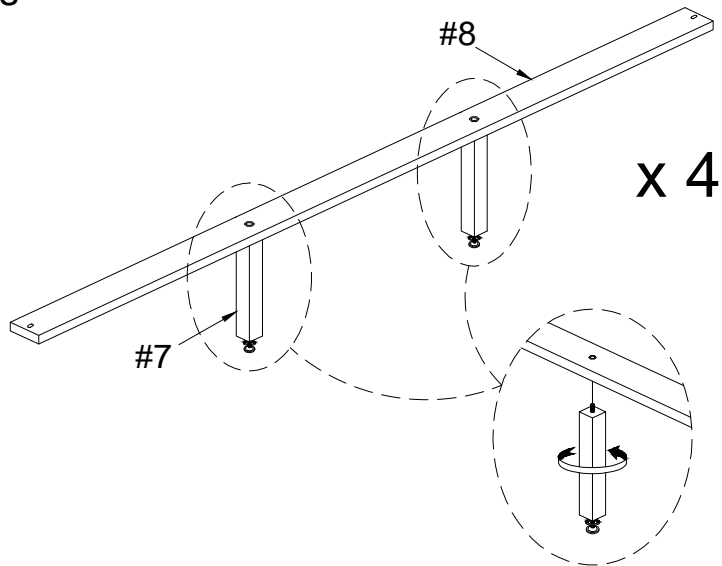

6

Hardware #E x8 pcs

Align slats to the side rails, secure by using screws (#E).

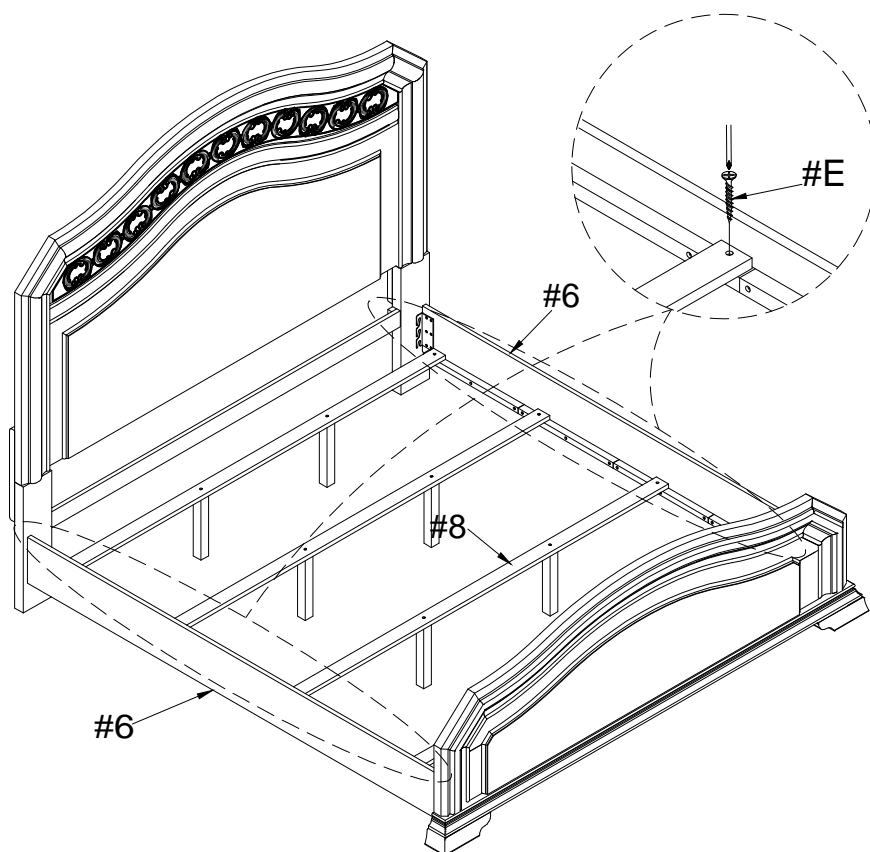

ASSEMBLY COMPLETED



Please ensure the furniture rests on an even and flat surface. If the product wobbles or feels loose, double-check all bolts and/or screws are properly tightened and secured.



Keep this handy!

Please retain this instruction manual and any order-related information for future reference.



Lift, don't drag!

To avoid damage to product please always LIFT the product when transporting or adjusting the placement.