

# ASSEMBLY INSTRUCTIONS

MODEL #

**CM7683CK**

Questions?

GIVE US CALL: 1-888-980-5122  
MON-FRI 8:30AM - 5:30PM (PST)

## TOOLS REQUIRED



Allen Wrench

(Included)



Phillips  
Screwdriver

(Not Included)

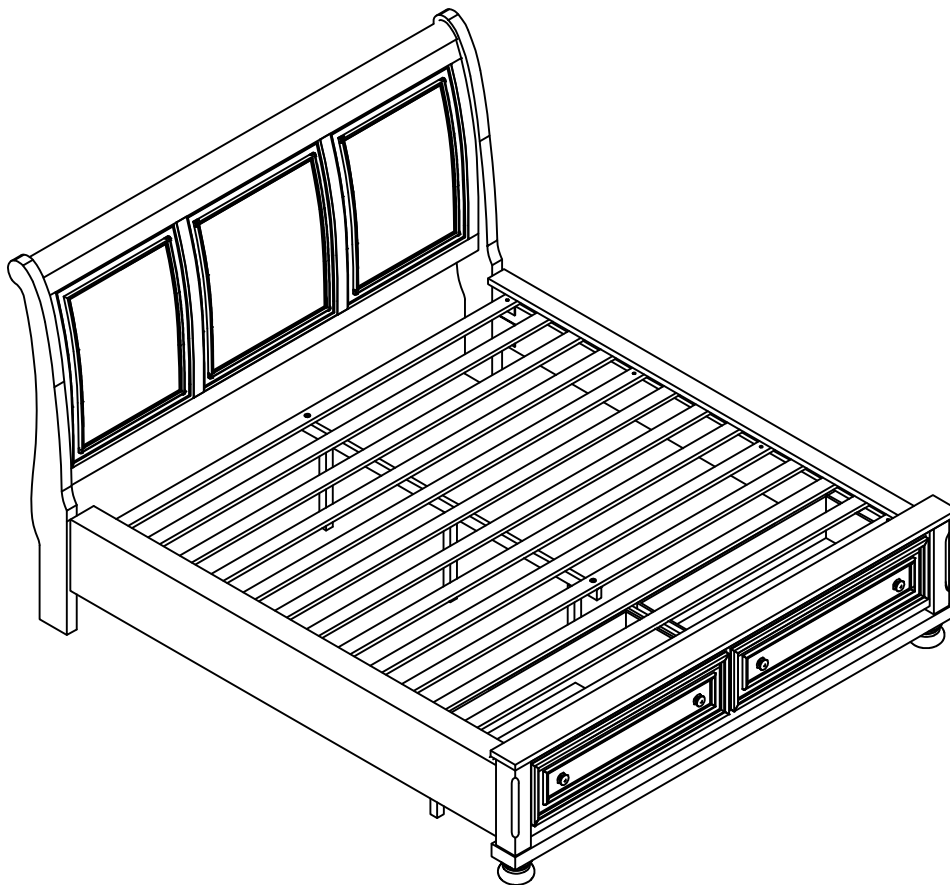

3 - People  
Recommended

## ASSEMBLY RATING



EASY —————> DIFFICULT

The Assembly Rating is a 5-point system showing the level of effort needed to assemble a specific product.



FOA Intro

Thank you for your purchase!

We hope you enjoy this new addition to your home for many years to come.

Our commitment to providing quality products does not simply end when you purchase our product. We fully stand behind our products from start to finish. Our customer service department is available Monday – Friday 8:30 AM – 5:30 PM Pacific and can help with assembly questions as well as, if necessary, replacing damaged or missing parts. To help expedite our service, please have these assembly instructions readily available, along with your order receipt.

 **Consumer Hotline**  
Toll-Free 1-888-980-5122

 **WEBSITE**  
[www.foagroup.com](http://www.foagroup.com)

    foagroup

 **Monday to Friday**  
8:30AM- 5:30PM (PST)

 **E-MAIL**  
[cs.ec@foagroup.com](mailto:cs.ec@foagroup.com)

 FurnitureOfAmerica

---

## CHECK BEFORE STARTING

**Are you missing anything?**

Double-check all parts, hardware and accessories listed on Page 6 are accounted for.

**Should we send any replacements?**

Are there any irregularities or flaws in the parts? We can send replacements!

**Check out our Quick Tips!**

We recommend reviewing the pre-assembly handouts. Even experts need a refresher now and then!

**Prep Time!**

Please review the assembly instructions and all diagrams prior to assembling. Arrange parts as recommended on Page 7 and group identical hardware together to make assembling easier.

# PRE ASSEMBLY INTRODUCTION

We understand building ready-to-assemble furniture can be a challenging experience for some. To help avoid confusion, we have provided some helpful tips that may speed up the process.



## Teamwork

ALWAYS have at least two people to help with transporting and assembling the product to avoid potential injury and/or damage.

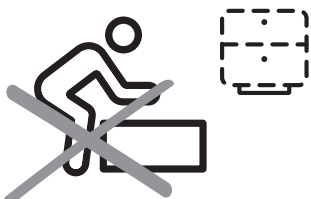

## Suitable Location

Assembling near the area of the intended location is highly recommended.



## Sufficient Space

Make sure you have enough space to move around during the assembly.

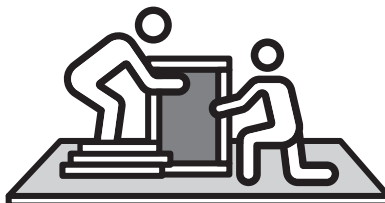

## Avoid Scratches

Use cardboard, blankets or a carpeted area while assembling furniture to prevent scratches.

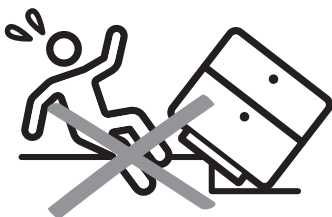

## Flat Surface

Make sure the furniture rests on a flat and level surface with each leg evenly touching the floor.

# ASSEMBLY AND CARE ADVICE



**FAILURE TO FOLLOW THE GUIDELINES BELOW MAY RESULT IN INJURY AND/OR PROPERTY DAMAGE.**



Position each part correctly and insert screws or bolts into their respective holes.

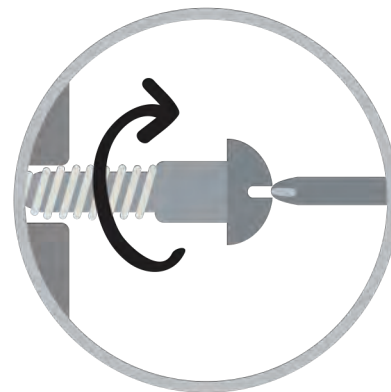

Turn clockwise to tighten and only tighten when step is completed or when instructed to do so.



Use the appropriate hand tools or power tools for assembly. Select steps, such as tightening screws and/or bolts, may require hand tools to avoid causing damage during assembly.



Save the instructions and store any supplied tools for later maintenance.



After two weeks, check and tighten any loose hardware and repeat again every six months thereafter.

**IT IS THE USER'S RESPONSIBILITY TO MAINTAIN THE FURNITURE. THE HARDWARE MAY LOOSEN OVER TIME AND MAY CAUSE THE FURNITURE TO BE WOBBLY AND UNABLE TO SUPPORT ITS INTENDED WEIGHT CAPACITY. THIS MAY LEAD TO COLLAPSE AND MAY CAUSE SERIOUS INJURY.**

# BED

CM7683CK



- Please keep instructions for future reference.
- Check the quantity and irregularity of parts and hardware before you start.

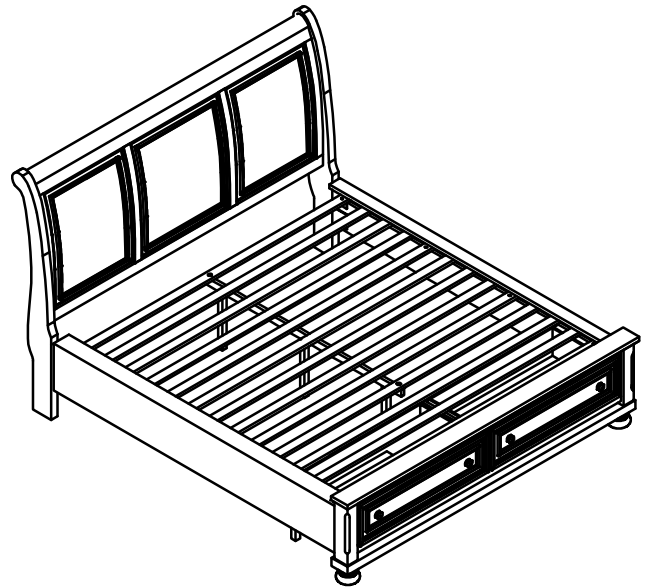

## PARTS

#1 1pc

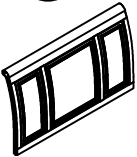

Headboard

#2 2pcs



Headboard Leg(L/R)

#3 1pc

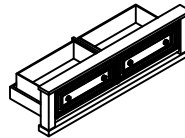

Footboard

#4 2pcs

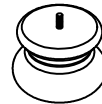

Footboard Leg

#5 3pcs

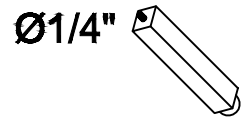

Support Leg  
32x32x150mm

#6 2pcs

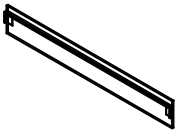

Side Rail

#7 1Set

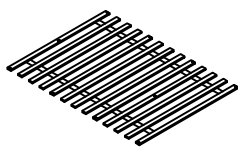

Slat

#8 1pc

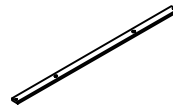

Support Rail

#9 3pcs



Rail Support Leg  
32x32x357mm

## HARDWARE

#A 6pcs

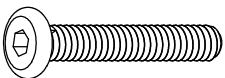

Bolt Ø5/16x1-3/4"

#B 6pcs



Lock Washer  
Ø5/16

#C 6pcs



Flat Washer  
Ø5/16

#D 1pc

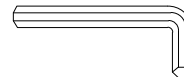

Allen Wrench M5

#E 2pcs



Bolt Ø1/4x1-1/4"

#F 2pcs



Lock Washer  
Ø1/4

#G 1pc



Flat Washer  
Ø1/4

#H 8pcs



Screw #8x30mm

#I 2pcs

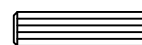

Wood Dowel

#J 1pc

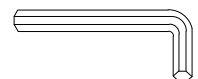





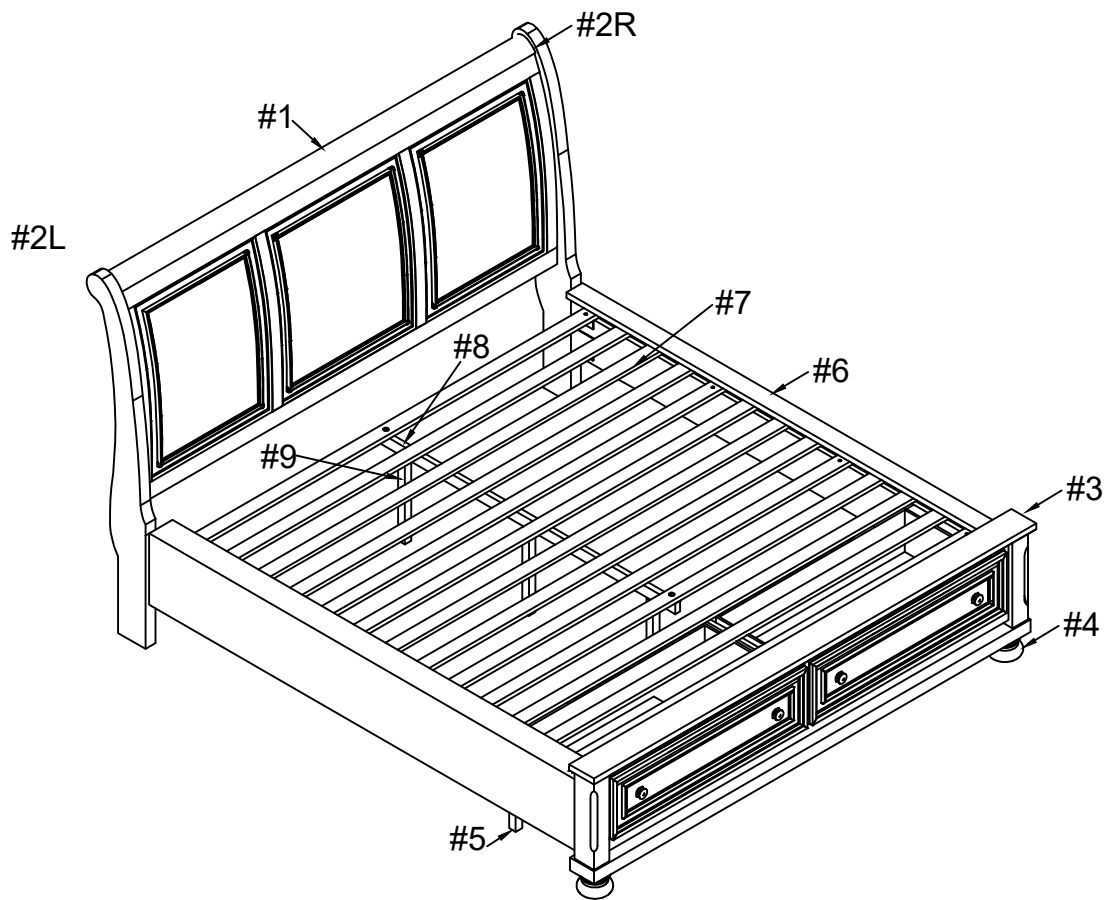









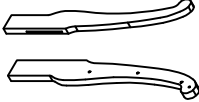
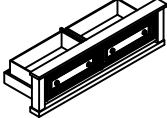

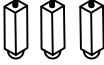
Allen Wrench M4

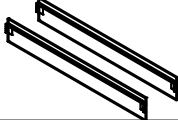
# Exploded View

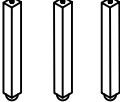

# CM7683CK is packed in 3 cases

Carton	Disignation	Part	Hardware
CM7683CK-HB	Headboard	#1 	 #A x 6pcs  #B x 6pcs  #Cx 6pcs  #D x 1pc  #Ix 2pcs
	Headboard Leg	#2 	
CM7683CK-FB	Footboard	#3 	
	Footboard Leg	#4 	
	Support Leg	#5 	
	Slat	#7 	
CM7683CK-R	Side Rail	#6 	 #E x 2pcs  #F x 2pcs  #Gx 1pcs  #Hx 8pcs  #J x 1pc
	Support Rail	#8 	
	Rail Support Leg	#9 	

# ASSEMBLY INSTRUCTIONS

## 1

- Part #1 x1pc
- Part #2 x2pcs
- Hardware #A x6pcs
- Hardware #B x6pcs
- Hardware #C x6pcs
- Hardware #I x2pcs

1) Attach wood dowels (#I) to the top hole of each headboard legs (#2R/L).

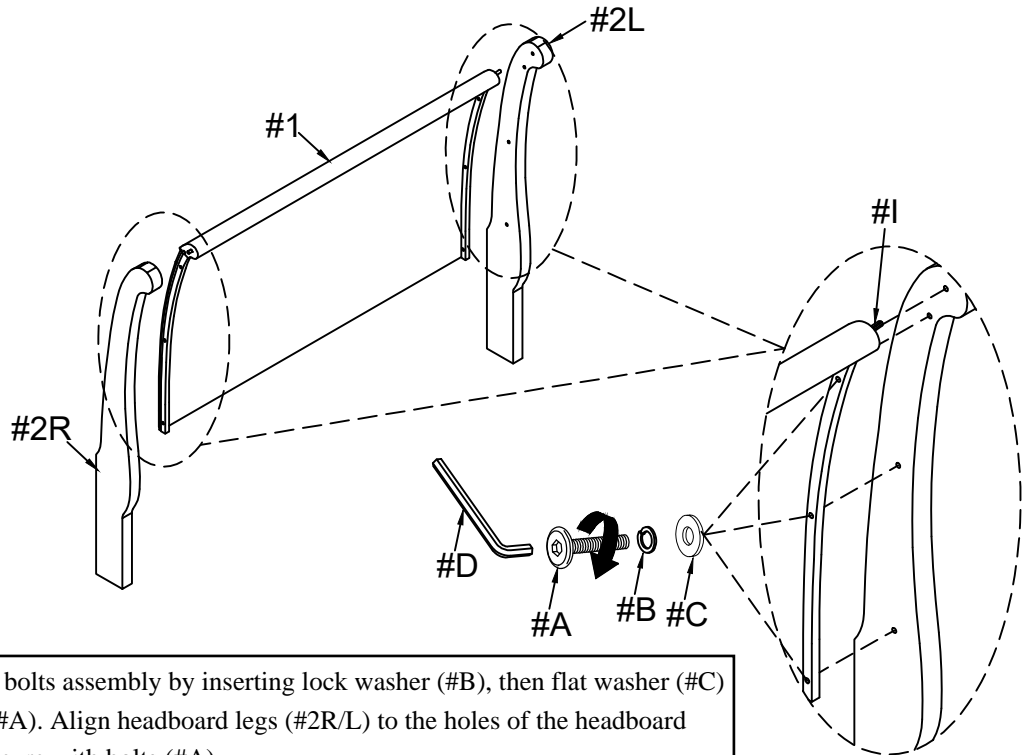

2) Prepare 6 bolts assembly by inserting lock washer (#B), then flat washer (#C) onto bolts (#A). Align headboard legs (#2R/L) to the holes of the headboard (#1), then secure with bolts (#A).

## 2

- Part #3 x1pc
- Part #4 x2pcs

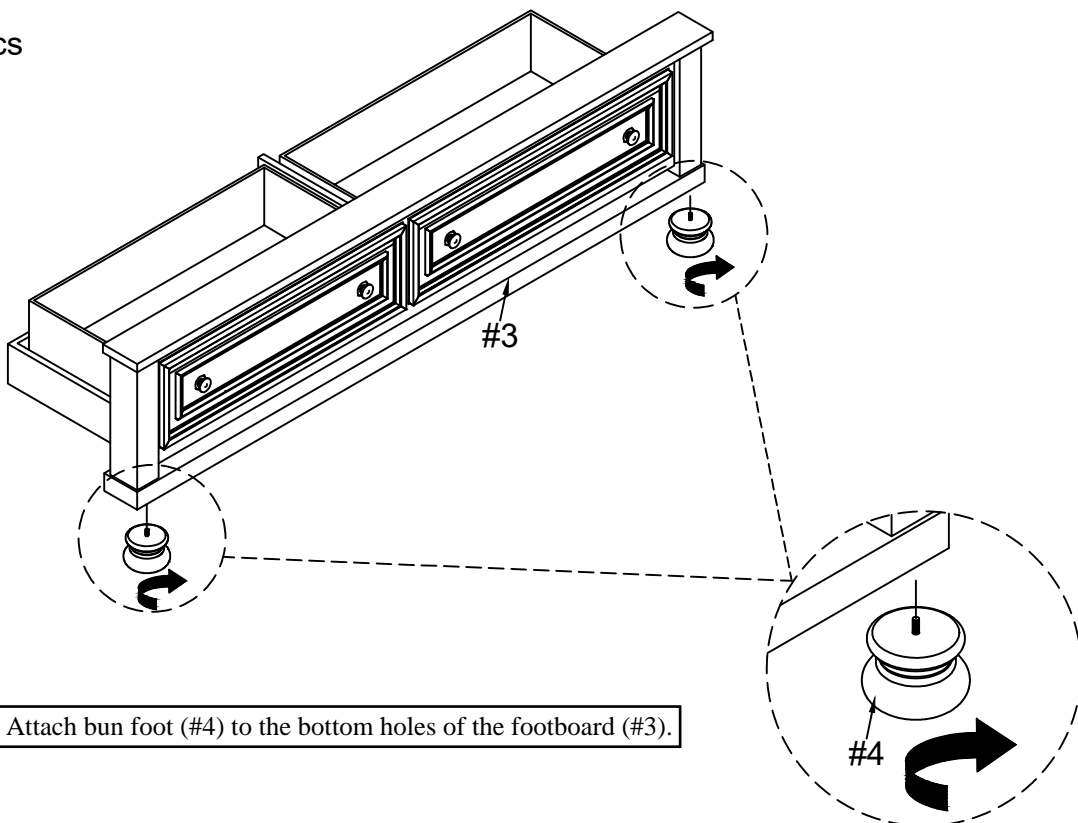

Attach bun foot (#4) to the bottom holes of the footboard (#3).



# ASSEMBLY INSTRUCTIONS

## 3

Attach support legs (#5) to the holes at the bottom of the footboard (#3).  
Adjust adjustable foot according to the ground level.

Part #5 x3pc

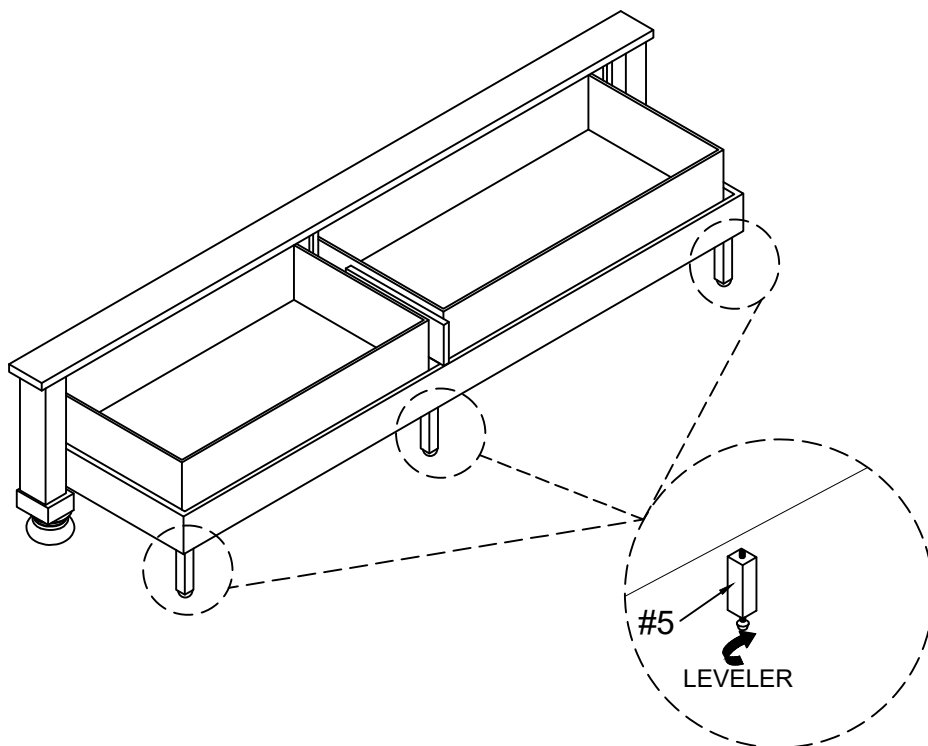

## 4

Part #6 x2pcs

Hook the side rails (#6) to the latch of the headboard (#1) and footboard (#3).  
Make sure it is firmly in place.

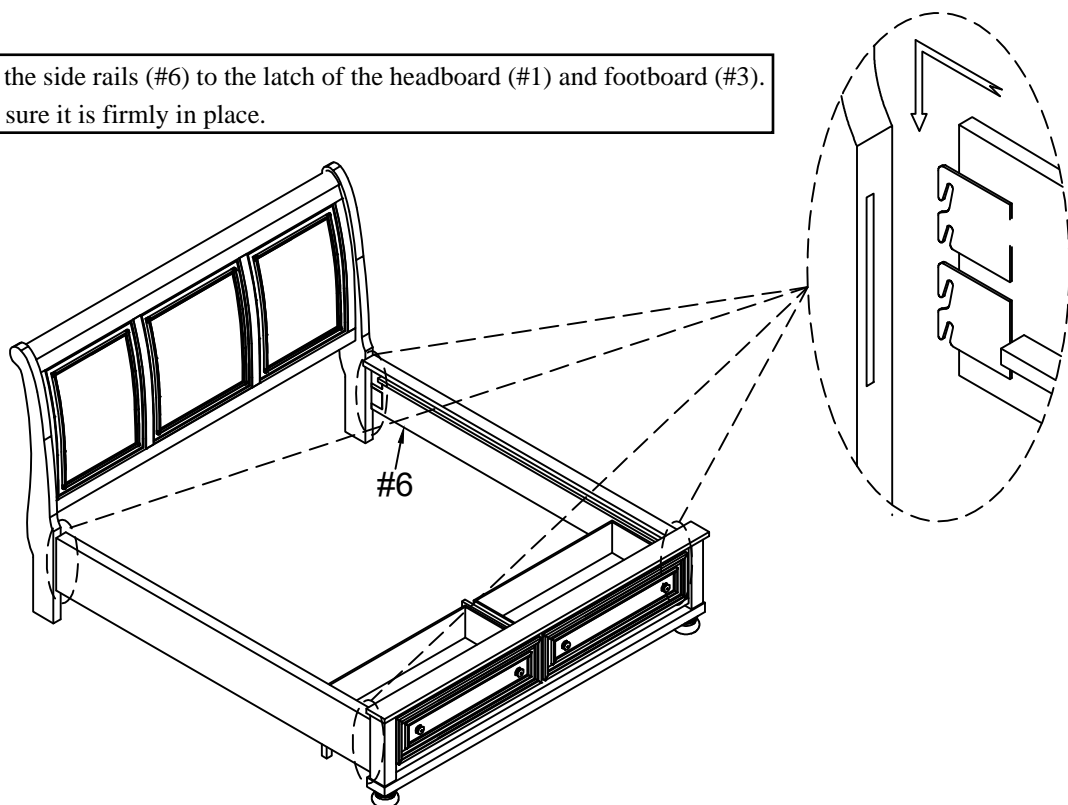

# ASSEMBLY INSTRUCTIONS

## 5

Part #8 x 1pc

Part #9 x 3pcs

Attach support legs (#9) to the holes of the support rails (#8).  
Adjust adjustable foot according to ground level.

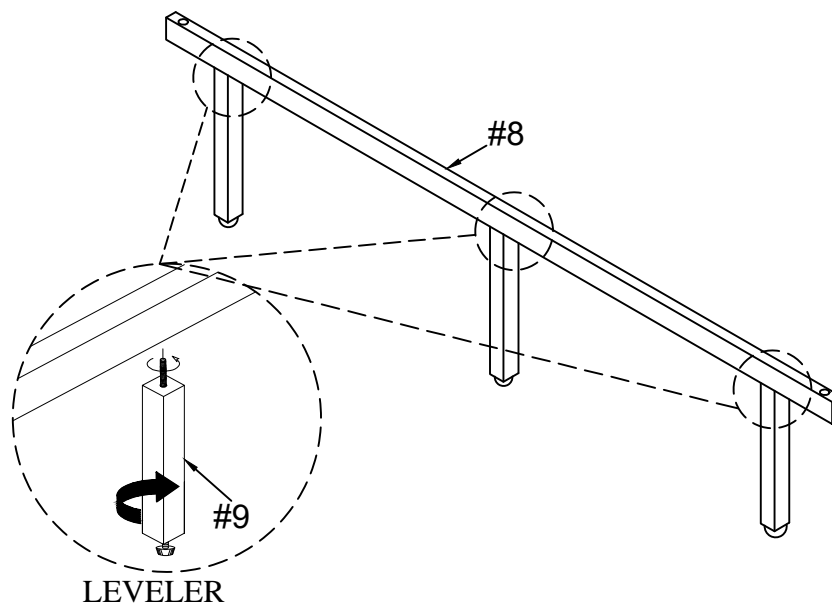

## 6

Part #7 x 1Set

Hardware #E x 2pcs

Hardware #F x 2pcs

Hardware #G x 2pcs

Prepare 2 bolts assembly by inserting lock washer (#F), then flat washer (#G) onto bolts (#E).  
Align slats (#7) to the holes of the support rail (#8). Secure with bolts (#E).

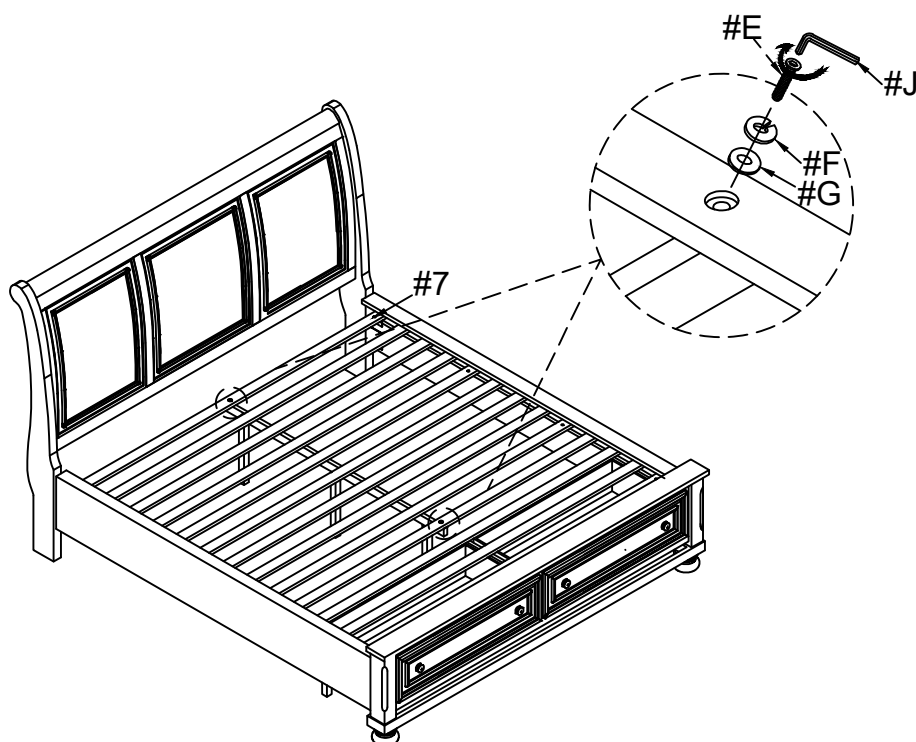

# ASSEMBLY INSTRUCTIONS

7

Hardware  x8pcs

Secure slats (#7) to the side rails (#6) with screws (#H).

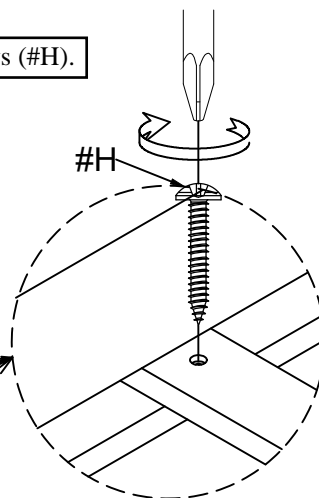
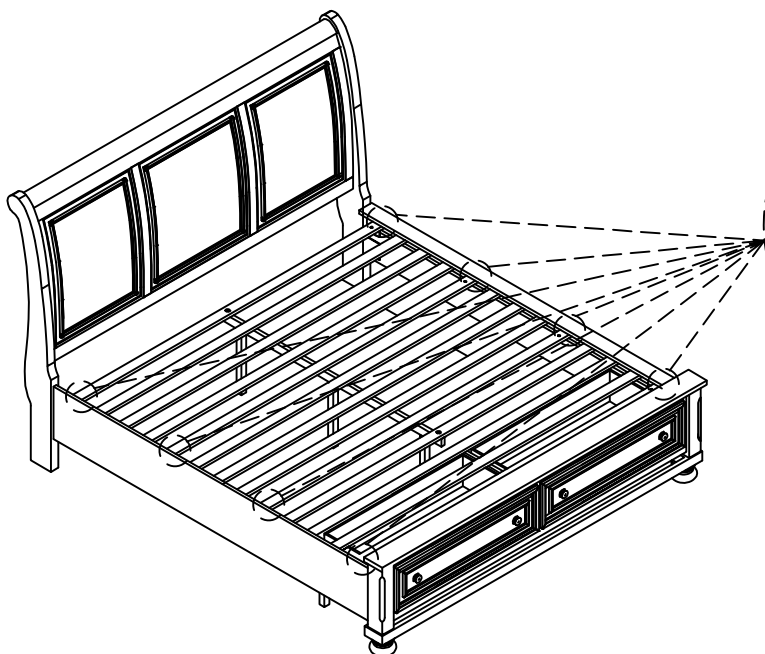

8

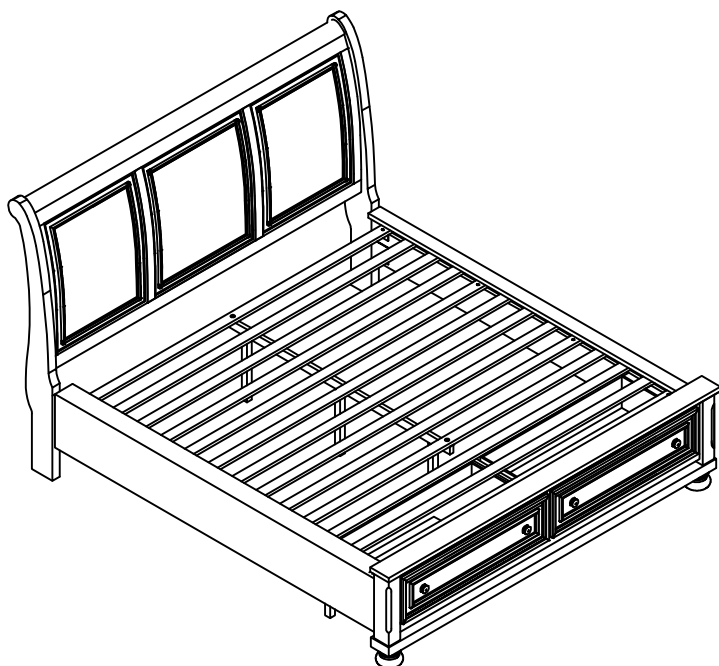

## ASSEMBLY COMPLETED



Please ensure the furniture rests on an even and flat surface. If the product wobbles or feels loose, double-check all bolts and/or screws are properly tightened and secured.



### Keep this handy!

Please retain this instruction manual and any order-related information for future reference.



### Lift, don't drag!

To avoid damage to product please always LIFT the product when transporting or adjusting the placement.