



Furniture of America®

E-Commerce by Enitial Lab

ASSEMBLY INSTRUCTIONS

MODEL #

CM7673Q

Questions?

GIVE US CALL: 1-888-980-5122
MON-FRI 8:30AM - 5:30PM (PST)

TOOLS REQUIRED



Allen Wrench
(Included)



Phillips Screwdriver
(Not Included)

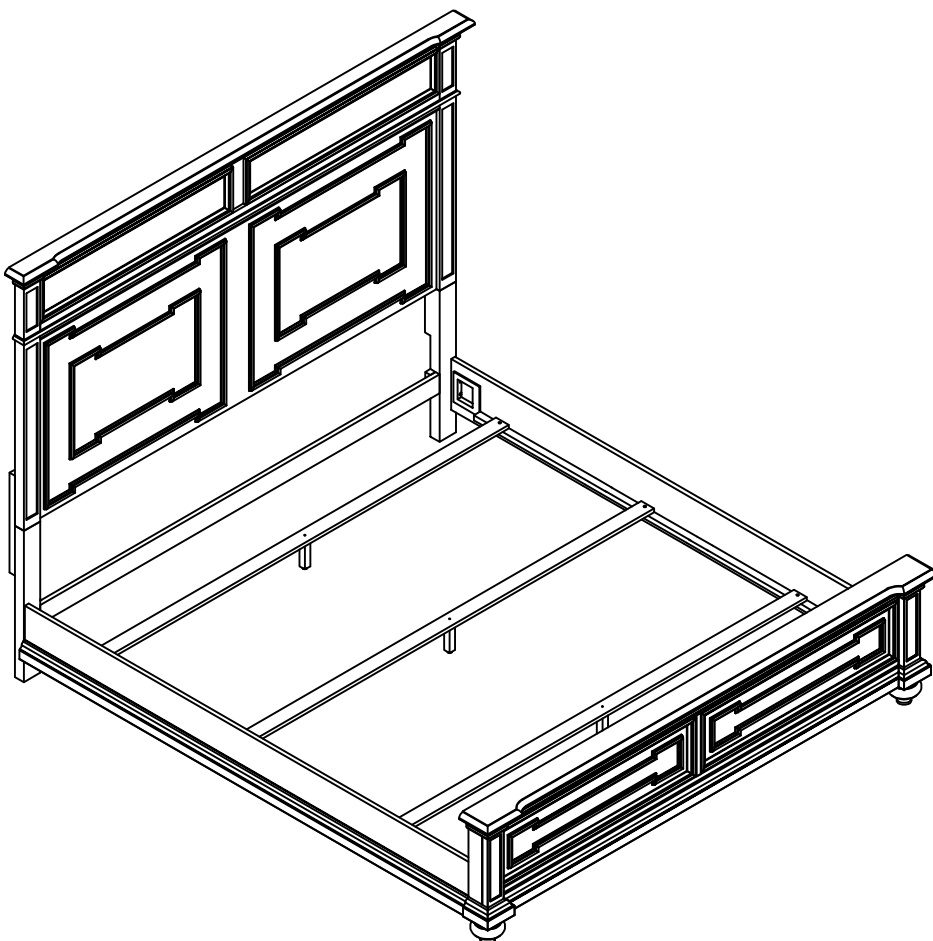

3 - People
Recommended

ASSEMBLY RATING



EASY —————> DIFFICULT

The Assembly Rating is a 5-point system showing the level of effort needed to assemble a specific product.





FOA Intro

Thank you for your purchase!

We hope you enjoy this new addition to your home for many years to come.

Our commitment to providing quality products does not simply end when you purchase our product. We fully stand behind our products from start to finish. Our customer service department is available Monday – Friday 8:30 AM – 5:30 PM Pacific and can help with assembly questions as well as, if necessary, replacing damaged or missing parts. To help expedite our service, please have these assembly instructions readily available, along with your order receipt.

 **Consumer Hotline**
Toll-Free 1-888-980-5122

 **Monday to Friday**
8:30AM- 5:30PM (PST)

 **WEBSITE**
www.foagroup.com

 **E-MAIL**
cs.ec@foagroup.com

    foagroup

 FurnitureOfAmerica

CHECK BEFORE STARTING

Are you missing anything?

Double-check all parts, hardware and accessories listed on Page 6 are accounted for.

Check out our Quick Tips!

We recommend reviewing the pre-assembly handouts. Even experts need a refresher now and then!

Should we send any replacements?

Are there any irregularities or flaws in the parts? We can send replacements!

Prep Time!

Please review the assembly instructions and all diagrams prior to assembling. Arrange parts as recommended on Page 7 and group identical hardware together to make assembling easier.

PRE ASSEMBLY INTRODUCTION

We understand building ready-to-assemble furniture can be a challenging experience for some. To help avoid confusion, we have provided some helpful tips that may speed up the process.

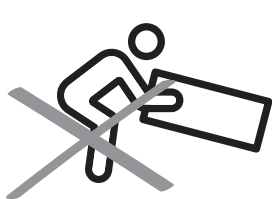

Teamwork

ALWAYS have at least two people to help with transporting and assembling the product to avoid potential injury and/or damage.

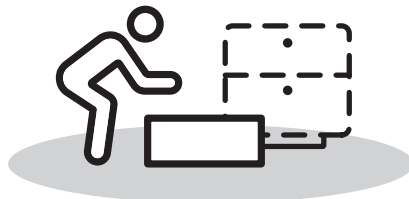
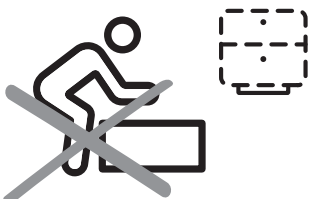

Suitable Location

Assembling near the area of the intended location is highly recommended.



Sufficient Space

Make sure you have enough space to move around during the assembly.

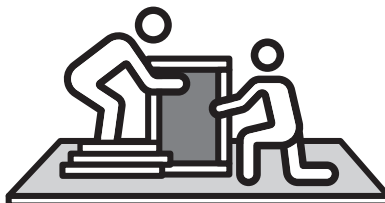

Avoid Scratches

Use cardboard, blankets or a carpeted area while assembling furniture to prevent scratches.

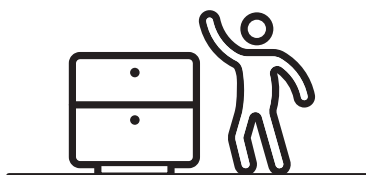
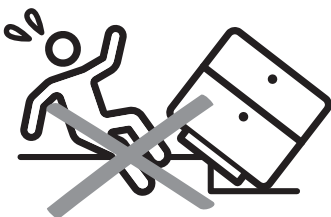

Flat Surface

Make sure the furniture rests on a flat and level surface with each leg evenly touching the floor.

ASSEMBLY AND CARE ADVICE



FAILURE TO FOLLOW THE GUIDELINES BELOW MAY RESULT IN INJURY AND/OR PROPERTY DAMAGE.



Position each part correctly and insert screws or bolts into their respective holes.



Turn clockwise to tighten and only tighten when step is completed or when instructed to do so.



Use the appropriate hand tools or power tools for assembly. Select steps, such as tightening screws and/or bolts, may require hand tools to avoid causing damage during assembly.



Save the instructions and store any supplied tools for later maintenance.



After two weeks, check and tighten any loose hardware and repeat again every six months thereafter.

IT IS THE USER'S RESPONSIBILITY TO MAINTAIN THE FURNITURE. THE HARDWARE MAY LOOSEN OVER TIME AND MAY CAUSE THE FURNITURE TO BE WOBBLY AND UNABLE TO SUPPORT ITS INTENDED WEIGHT CAPACITY. THIS MAY LEAD TO COLLAPSE AND MAY CAUSE SERIOUS INJURY.

QUEEN BED

CM7673Q



- Please keep instructions for future reference.
- Check the quantity and irregularity of parts and hardware before you start.

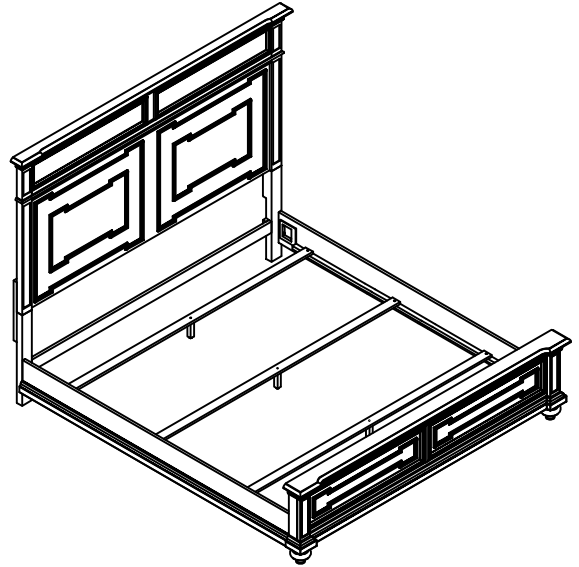

PARTS

#1 1pc



Headboard Panel

#2 2pcs

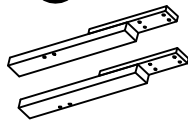

HB Leg (L&R)

#3 1pc

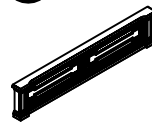

Footboard Panel

#4 2pcs



Side Rail

#5 1pc

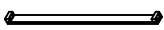

Headboard Support

#6 3pcs



Bed Slat

#7 3pcs

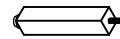

Support Leg

#8 2pcs



Footboard Leg

HARDWARE

#A 8pcs



Bolt
Ø5/16" x 2"

#B 8pcs



Lock Washer
Ø5/16"

#C 8pcs



Flat Washer
Ø5/16"

#D 1pc



Allen Wrench
4mm

#E 6pcs



Screw
#4 x 1-3/16"

#F 8pcs



Threaded Pins
Ø5/16" x 3-1/2"

#G 8pcs



Hex Nut
Ø5/16"

#H 1pc



Wrench
12mm

#I 2pcs

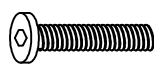

Bolt
Ø1/4" x 1-3/4"

#K 2pcs













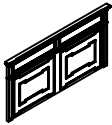

Lock Washer
Ø1/4"

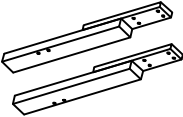
#L 2pcs

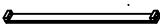
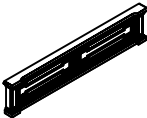
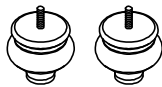
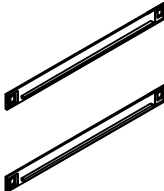
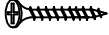

Flat Washer
Ø1/4"

CM7673Q is packed in 3 cases

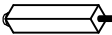
Carton	Disignation		Part	Hardware
CM7673Q-HB	Headboard Panel	#1		 #A 8pcs  #B 8pcs  #C 8pcs  #D 1pc
	HB Leg (L&R)	#2		 #I 2pcs  #K 2pcs  #L 2pcs
	HB Support	#5		
CM7673Q-FB	Footboard	#3		
	Footboard Leg	#8		
CM7673Q-R	Side Rail	#4		 #E 6pcs  #F 8pcs  #G 8pcs  #H 1pc
	Bed Slat	#6	 x 3	
	Support Leg	#7	 x 3	

Exploded View

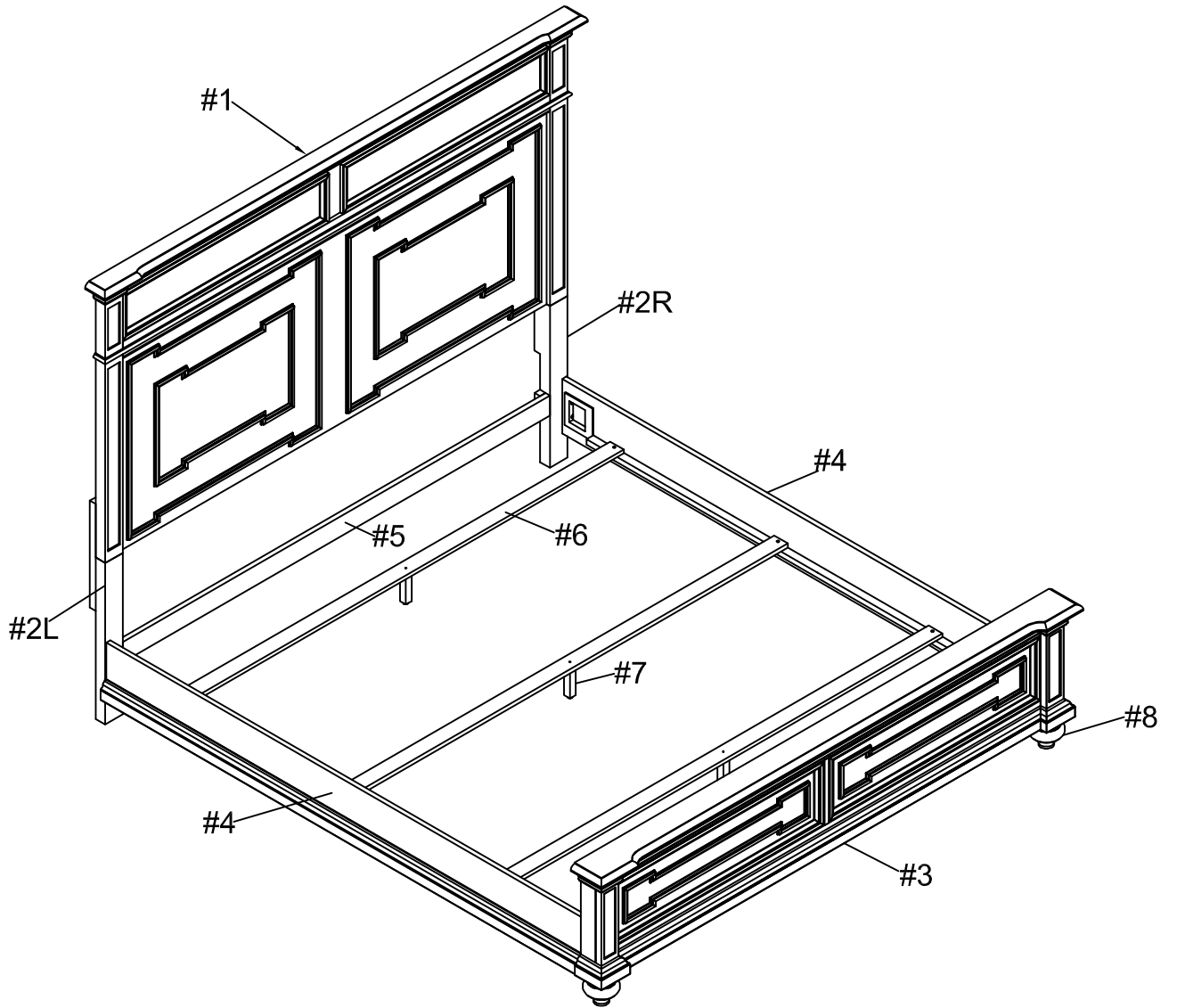

ASSEMBLY INSTRUCTIONS

1

- Part #1 x1pc
- Part #2 x2pcs
- Part #5 x1pc
- Hardware #A x8pcs
- Hardware #B x8pcs
- Hardware #C x8pcs
- Hardware #D x1pc
- Hardware #I x2pcs
- Hardware #K x2pcs
- Hardware #L x2pcs

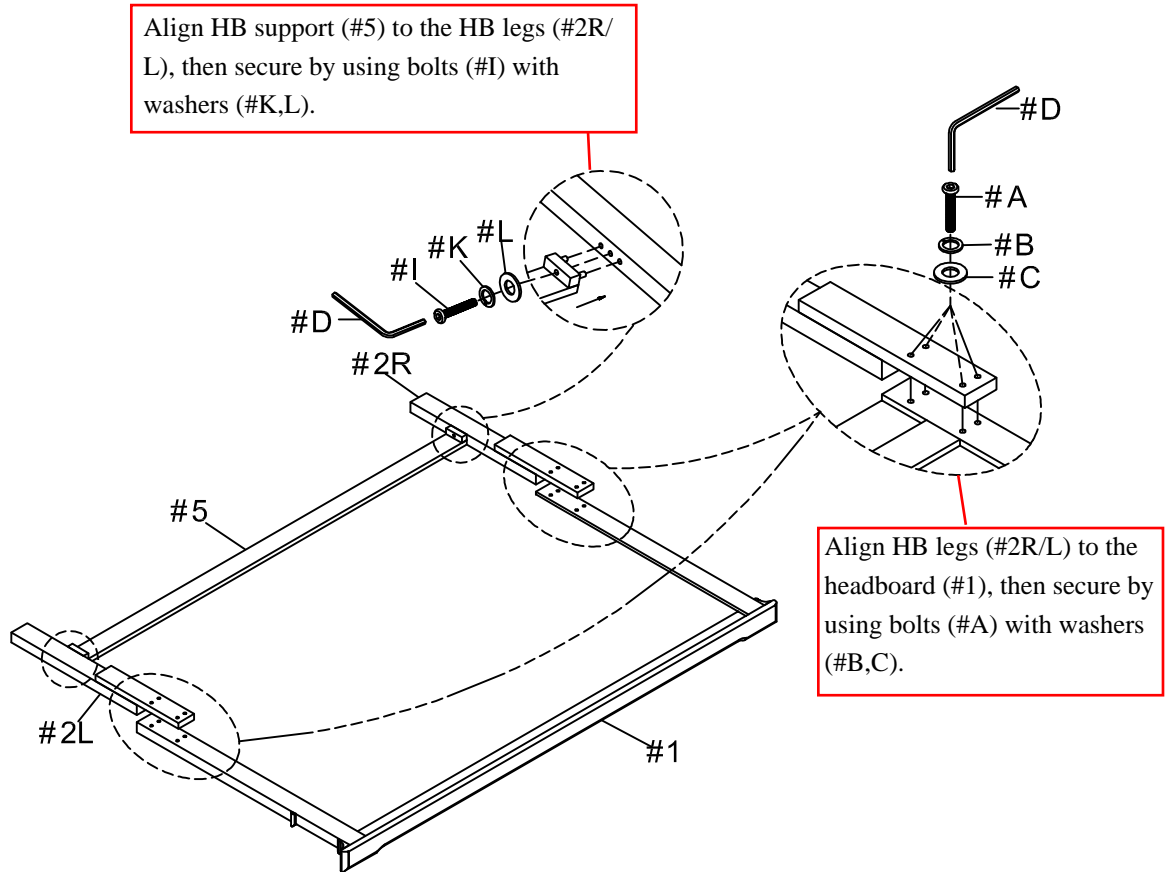

2

- Part #3 x1pc
- Part #8 x2pcs

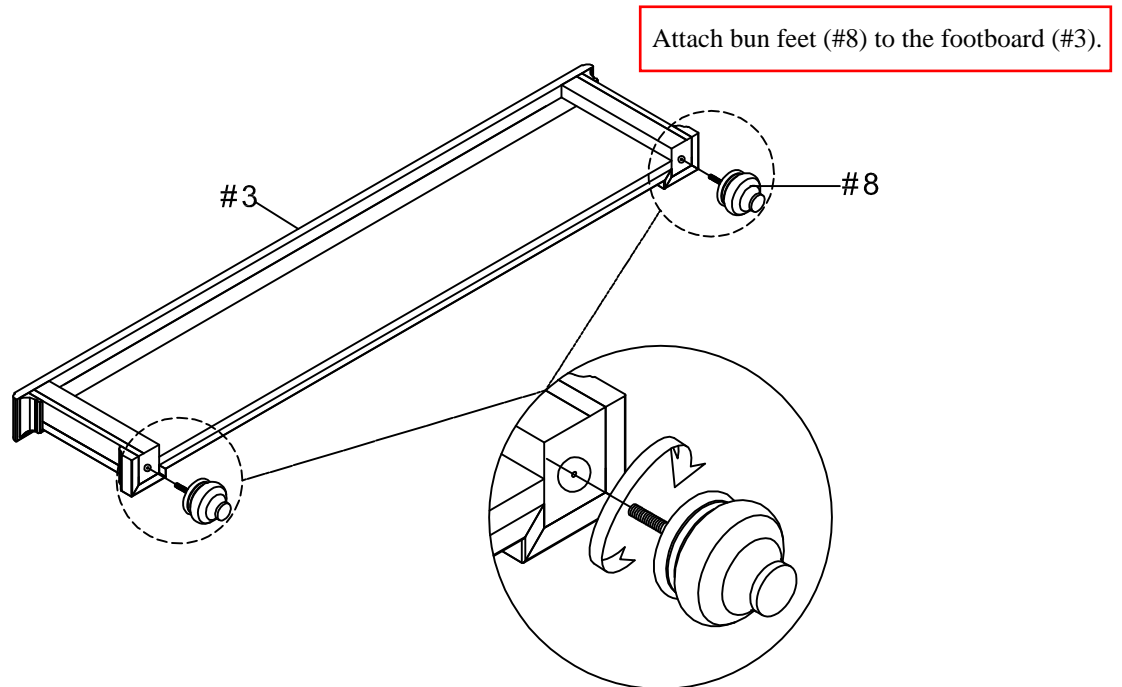

ASSEMBLY INSTRUCTIONS

3

- Part #4 x2pcs
- Hardware #F x8pcs
- Hardware #G x8pcs
- Hardware #H x1pc

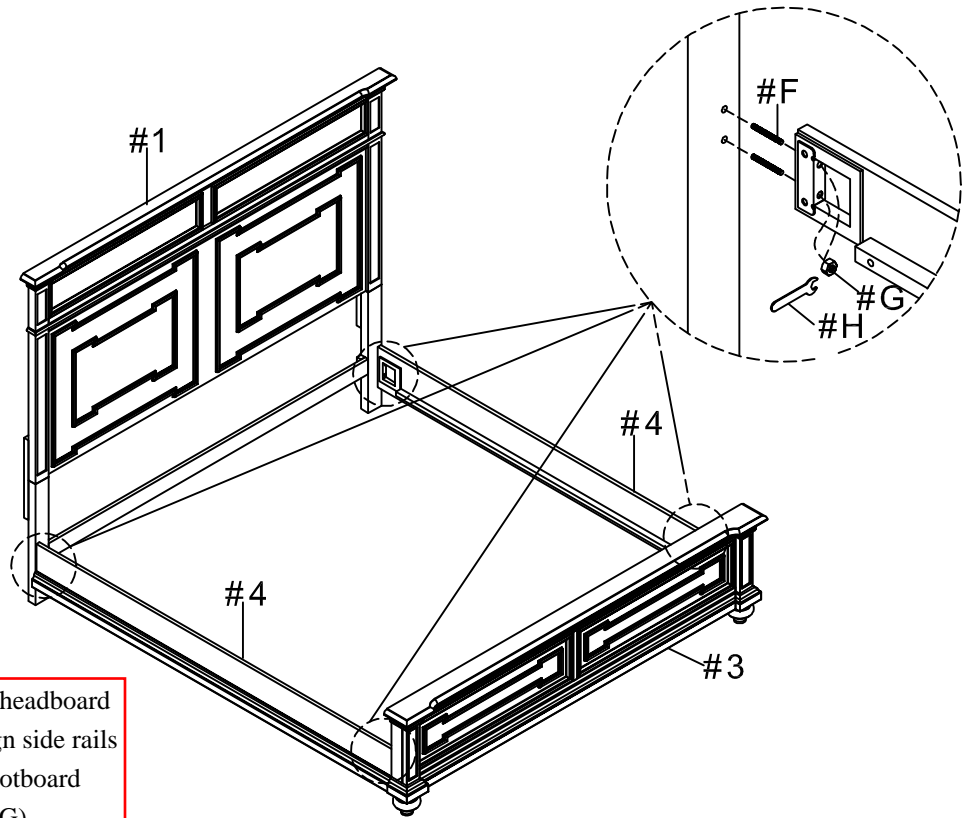

Attach threaded bolts (#F) to the headboard (#1) and footboard (#3), then align side rails (#4) to the headboard (#1) and footboard (#3). Secure by using hex nuts (#G).

4

- Part #6 x3pcs
- Part #7 x3pcs

Attach support legs (#7) to the slats (#6).

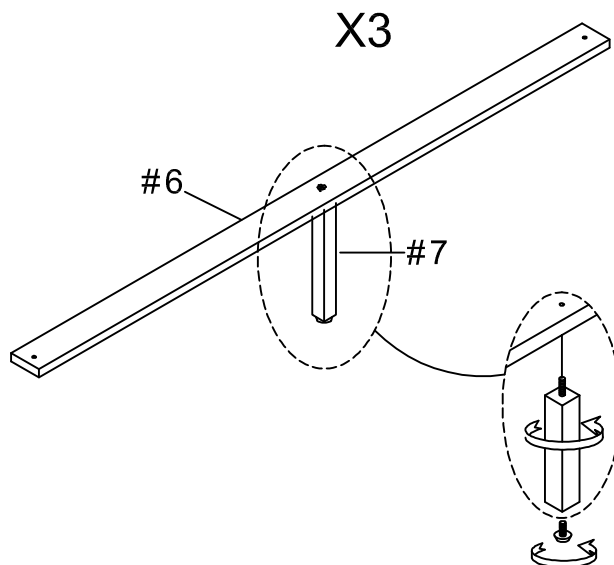

ASSEMBLY INSTRUCTIONS

5

Part #6 x3pcs
Hardware #E x6pcs

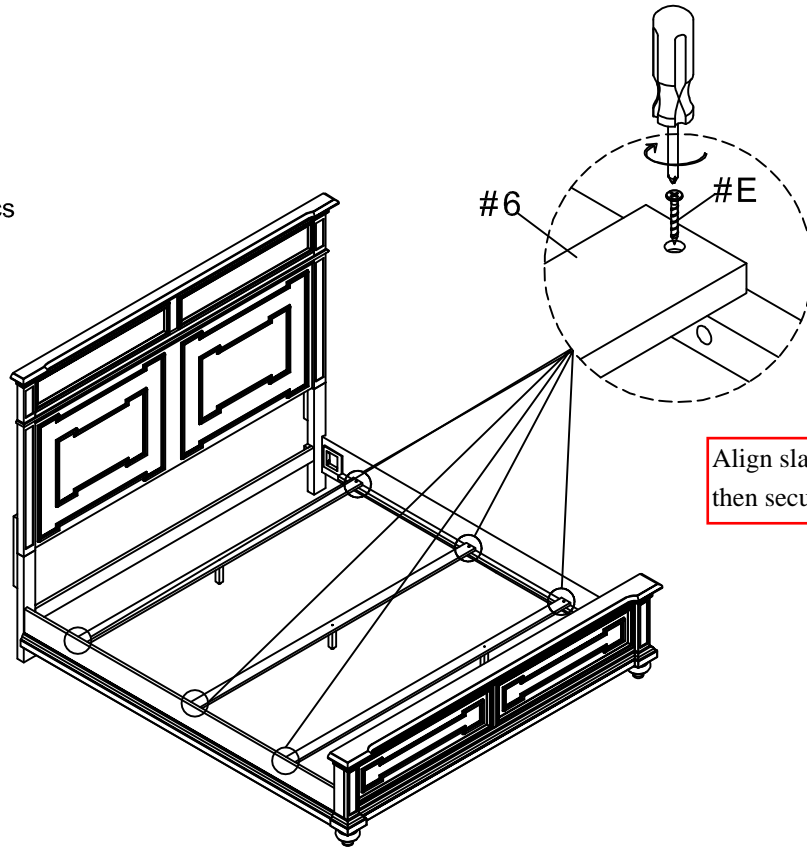

Align slats (#6) to the side rails, then secure by using screws (#E).

6

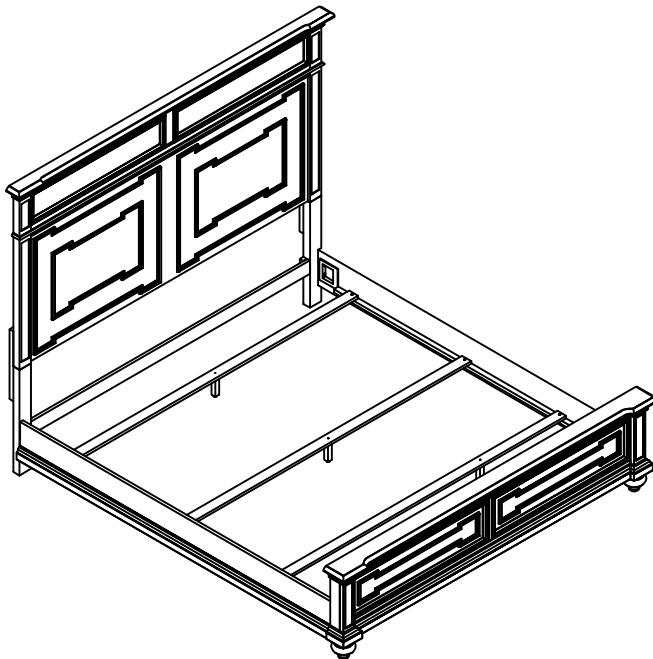

ASSEMBLY COMPLETED



Please ensure the furniture rests on an even and flat surface. If the product wobbles or feels loose, double-check all bolts and/or screws are properly tightened and secured.



Keep this handy!

Please retain this instruction manual and any order-related information for future reference.



Lift, don't drag!

To avoid damage to product please always LIFT the product when transporting or adjusting the placement.