



Furniture of America[®]

E-Commerce by Enitial Lab

ASSEMBLY INSTRUCTIONS

MODEL #

CM7590EK

Questions?

GIVE US CALL: 1-888-980-5122
MON-FRI 8:30AM - 5:30PM (PST)

TOOLS REQUIRED



Allen Wrench
(Included)



Phillips Screwdriver
(Not Included)



Wrench
(Included)



3 - People
Recommended

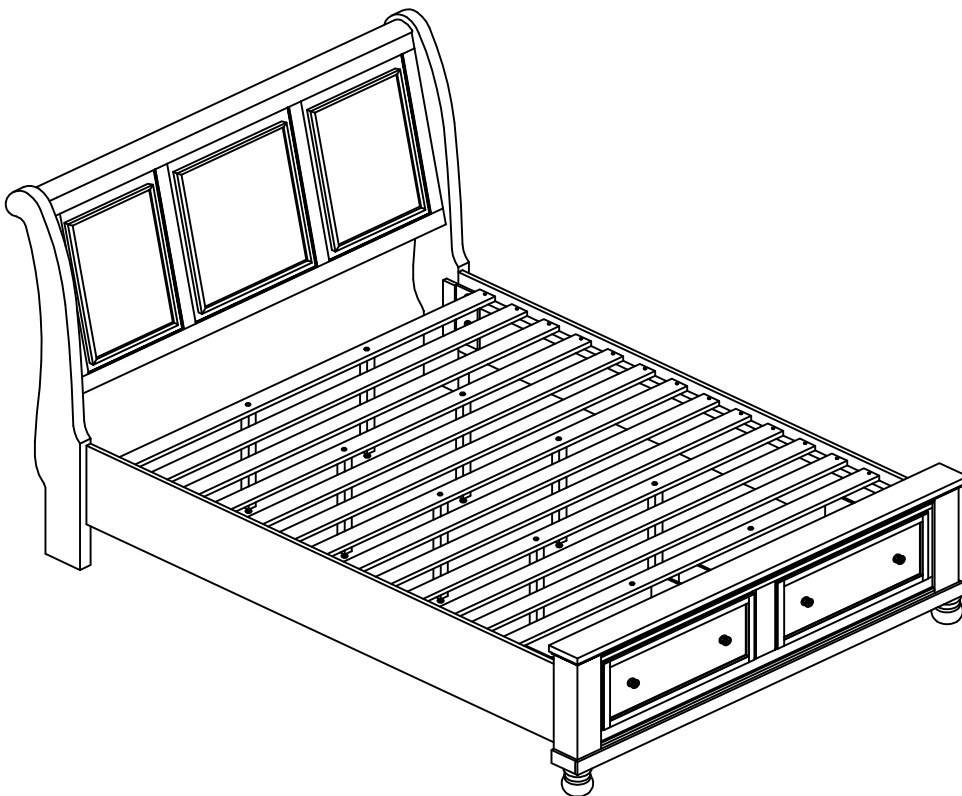

ASSEMBLY RATING



EASY —————> DIFFICULT

The Assembly Rating is a 5-point system showing the level of effort needed to assemble a specific product.





FOA Intro

Thank you for your purchase!

We hope you enjoy this new addition to your home for many years to come.

Our commitment to providing quality products does not simply end when you purchase our product. We fully stand behind our products from start to finish. Our customer service department is available Monday – Friday 8:30 AM – 5:30 PM Pacific and can help with assembly questions as well as, if necessary, replacing damaged or missing parts. To help expedite our service, please have these assembly instructions readily available, along with your order receipt.

 **Consumer Hotline**
Toll-Free 1-888-980-5122

 **Monday to Friday**
8:30AM- 5:30PM (PST)

 **WEBSITE**
www.foagroup.com

 **E-MAIL**
cs.ec@foagroup.com

    foagroup

 FurnitureOfAmerica

CHECK BEFORE STARTING

Are you missing anything?

Double-check all parts, hardware and accessories listed on Page 6 are accounted for.

Check out our Quick Tips!

We recommend reviewing the pre-assembly handouts. Even experts need a refresher now and then!

Should we send any replacements?

Are there any irregularities or flaws in the parts? We can send replacements!

Prep Time!

Please review the assembly instructions and all diagrams prior to assembling. Arrange parts as recommended on Page 7 and group identical hardware together to make assembling easier.

PRE ASSEMBLY INTRODUCTION

We understand building ready-to-assemble furniture can be a challenging experience for some. To help avoid confusion, we have provided some helpful tips that may speed up the process.

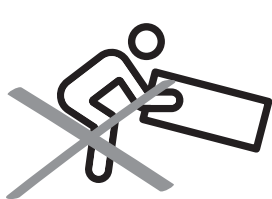

Teamwork

ALWAYS have at least two people to help with transporting and assembling the product to avoid potential injury and/or damage.

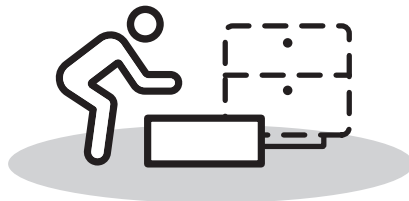
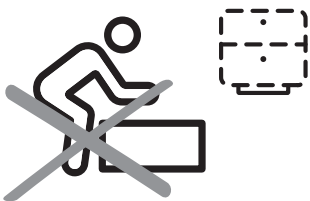

Suitable Location

Assembling near the area of the intended location is highly recommended.



Sufficient Space

Make sure you have enough space to move around during the assembly.

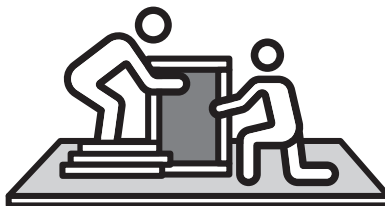

Avoid Scratches

Use cardboard, blankets or a carpeted area while assembling furniture to prevent scratches.

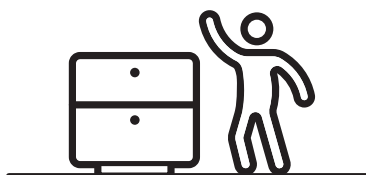
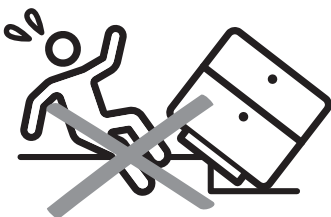

Flat Surface

Make sure the furniture rests on a flat and level surface with each leg evenly touching the floor.

ASSEMBLY AND CARE ADVICE



FAILURE TO FOLLOW THE GUIDELINES BELOW MAY RESULT IN INJURY AND/OR PROPERTY DAMAGE.



Position each part correctly and insert screws or bolts into their respective holes.

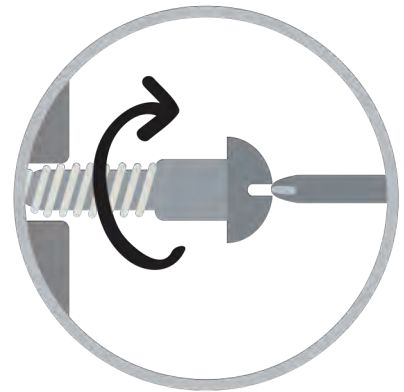

Turn clockwise to tighten and only tighten when step is completed or when instructed to do so.



Use the appropriate hand tools or power tools for assembly. Select steps, such as tightening screws and/or bolts, may require hand tools to avoid causing damage during assembly.

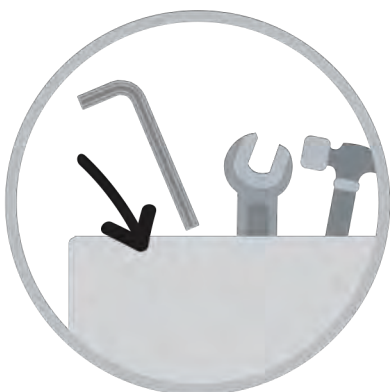

Save the instructions and store any supplied tools for later maintenance.

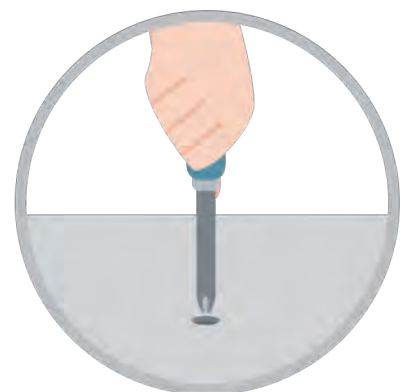

After two weeks, check and tighten any loose hardware and repeat again every six months thereafter.

IT IS THE USER'S RESPONSIBILITY TO MAINTAIN THE FURNITURE. THE HARDWARE MAY LOOSEN OVER TIME AND MAY CAUSE THE FURNITURE TO BE WOBBLY AND UNABLE TO SUPPORT ITS INTENDED WEIGHT CAPACITY. THIS MAY LEAD TO COLLAPSE AND MAY CAUSE SERIOUS INJURY.

E.KING BED

CM7590EK



- Please keep instructions for future reference.
- Check the quantity and irregularity of parts and hardware before you start.

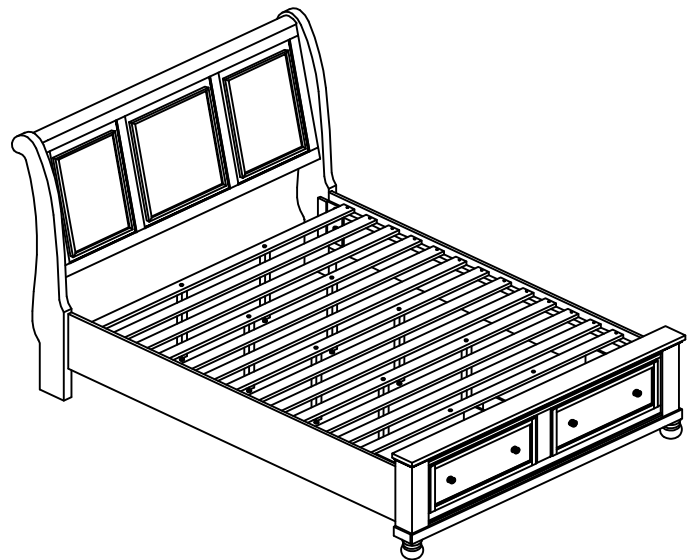

PARTS

#1 1pc

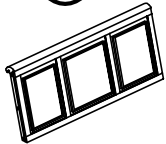

Headboard

#2 2pcs



Headboard Leg (L&R)

#3 1pc



Headboard cross bar

#4 2pcs



Side Rail

#5 1pcs

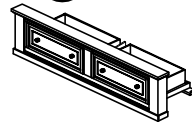

Footboard

#6 2pcs



Footboard bunfoot

#7 1 Set

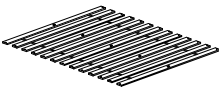

Slat (13pcs)

#8 2pcs



Drawer support leg $\text{Ø}\frac{5}{16}$ "
155 x 30 x 30mm

#9 8pcs

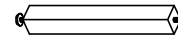

Slat support leg $\text{Ø}\frac{5}{16}$ "
390 x 30 x 30mm

HARDWARE

#A 8pcs



Bolt 5/16" x 1-3/8"

#B 16pcs



Lock washer
Ø5/16"

#C 16pcs



Flat washer
Ø5/16"

#D 1pc



Allen wrench M4

HARDWARE

#E 2pcs



Bolt 1/4" x 1-5/8"

#F 2pcs



Lock washer
Ø1/4"

#G 2pcs



Flat washer
Ø1/4"x19mm

#H 26pcs



Screw #4 x 30mm

#I 3pcs



Thread rod
Ø5/16" x 3-1/8"

#J 8pcs

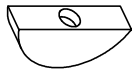

Half moon washer

#K 8pcs



Hex nut Ø5/16"

#L 1pc







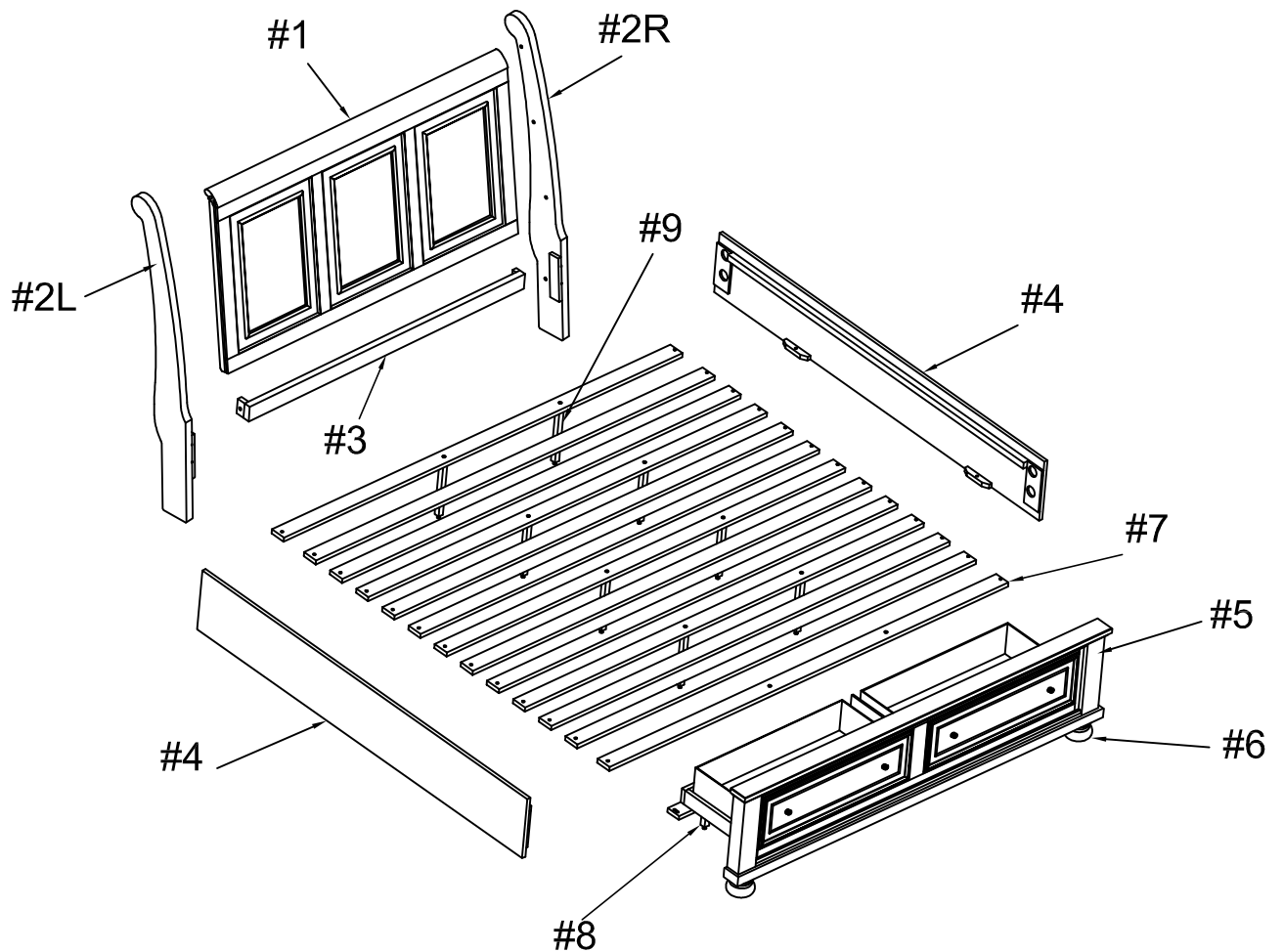



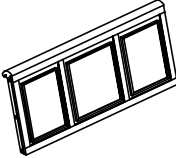
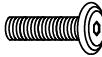

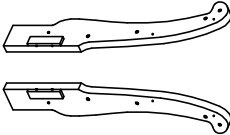



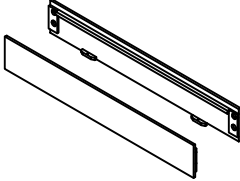

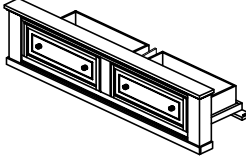

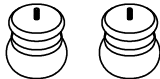
Wrench

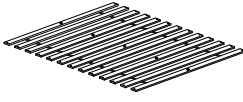
Exploded View

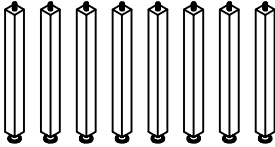

CM7590EK is packed in 3 cases

Carton	Disignation	Part		Hardware
CM7590 EK-HB	Headboard	#1		 #A x 8pcs  #B x 8pcs
	Headboard Leg (L&R)	#2		 #C x 8pcs  #D x 1pc
	Headboard cross bar	#3		
CM7590 EK-R	Side Rail	#4		 #B x 8pcs  #C x 8pcs
CM7590 EK-FB	Footboard	#5		 #I x 8pcs  #J x 8pcs
	Footboard bunfoot	#6		 #K x 8pcs  #L x 1pc
	Slat (13pcs)	#7		 #E x 2pcs
	Drawer support leg	#8		 #F x 2pcs  #G x 2pcs
	Slat support leg	#9		 #H x 26pcs  #D x 1pc

ASSEMBLY INSTRUCTIONS

1

Prepare 8 bolts assembly by inserting lock washer (#B), then flat washer (#C) onto bolts (#A). Align headboard (#1) and headboard cross bar (#3) to the holes of the headboard legs (#2R/L). Secure by using bolts (#A).

- Part #1 x1pc
- Part #2 x2pcs
- Part #3 x1pc
- Hardware #A x8pcs
- Hardware #B x8pcs
- Hardware #C x8pcs

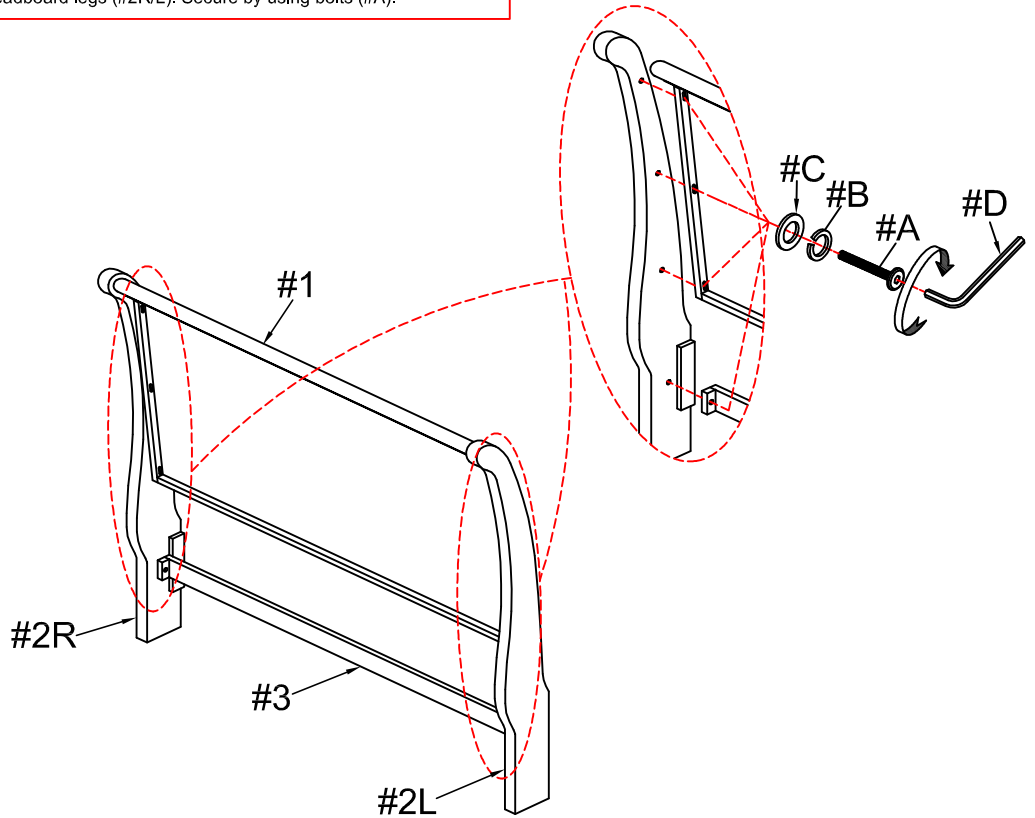

2

- Part #5 x1pc
- Part #6 x2pcs

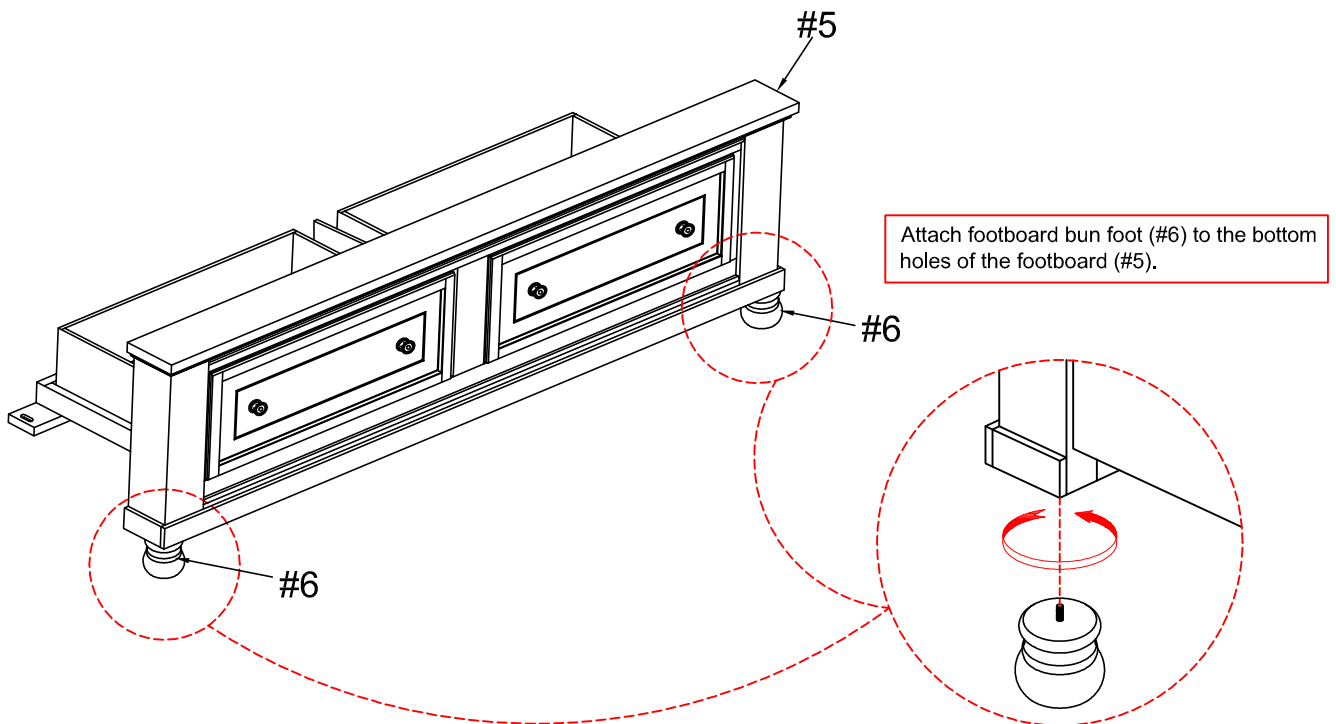

ASSEMBLY INSTRUCTIONS

3

Attach support legs (#8) to the bottom holes of the footboard (#5).
Adjust the leveler of the support legs (#8) according to ground level.

Part #8 x2pcs

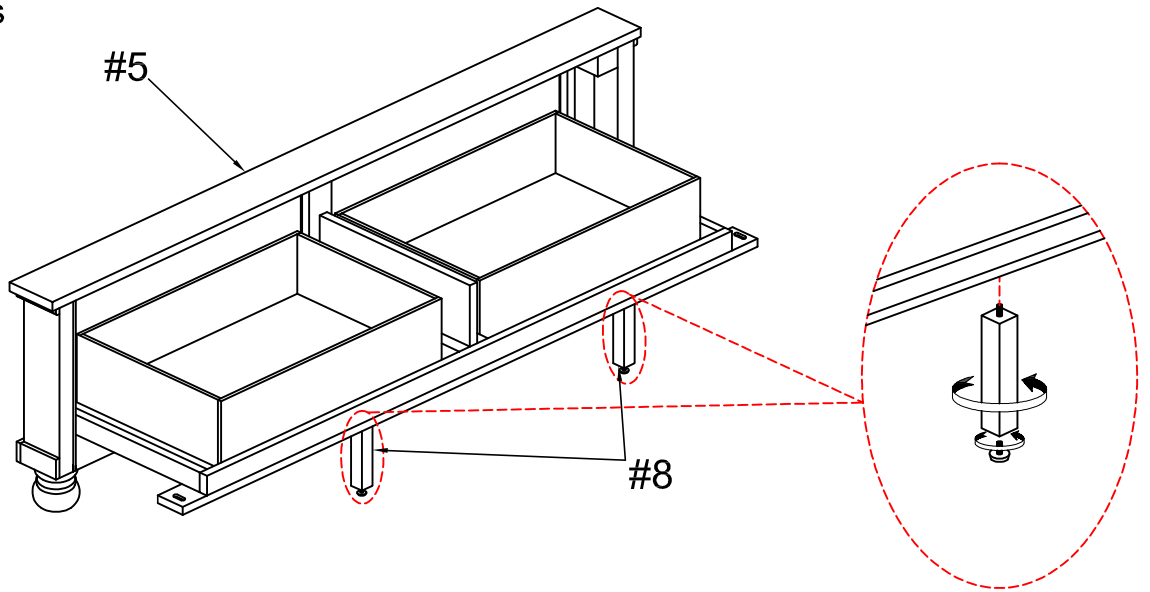

4

Attach threaded bolts (#1) to the foot board (#5) and headboard (#1). Align side rails (#4) to the threaded bolts of the foot board (#5) and headboard (#1). Secure by inserting half moon (#J), flat washer (#C), lock washer (#B) and hex nut (#K).

Part #4 x2pcs

Hardware #B x8pcs

Hardware #C x8pcs

Hardware #I x8pcs

Hardware #J x8pcs

Hardware #K x8pcs

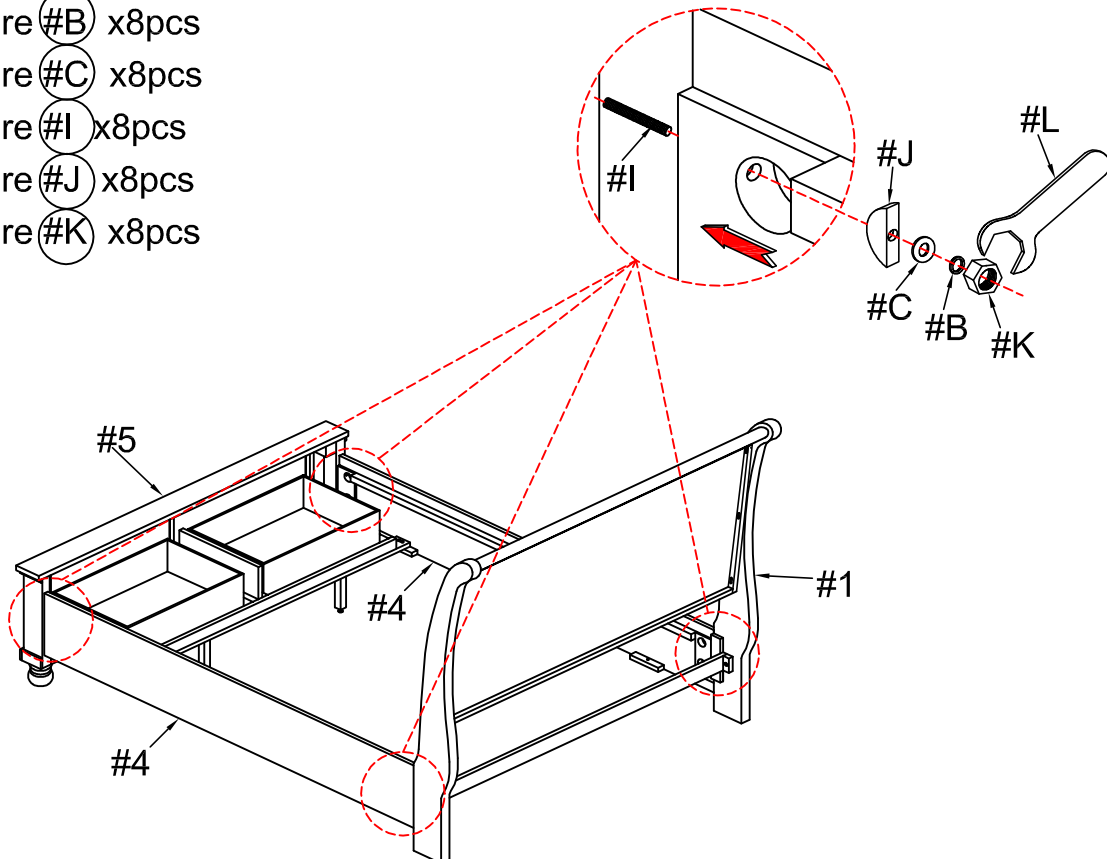

ASSEMBLY INSTRUCTIONS

5

Prepare 2 bolts assembly by inserting lock washer (#F), then flat washer (#G) onto bolts (#E). Align and secure foot board (#5) to the side rails (#4) by using bolts (#E).

Hardware (#E) x2pcs

Hardware (#F) x2pcs

Hardware (#G) x2pcs

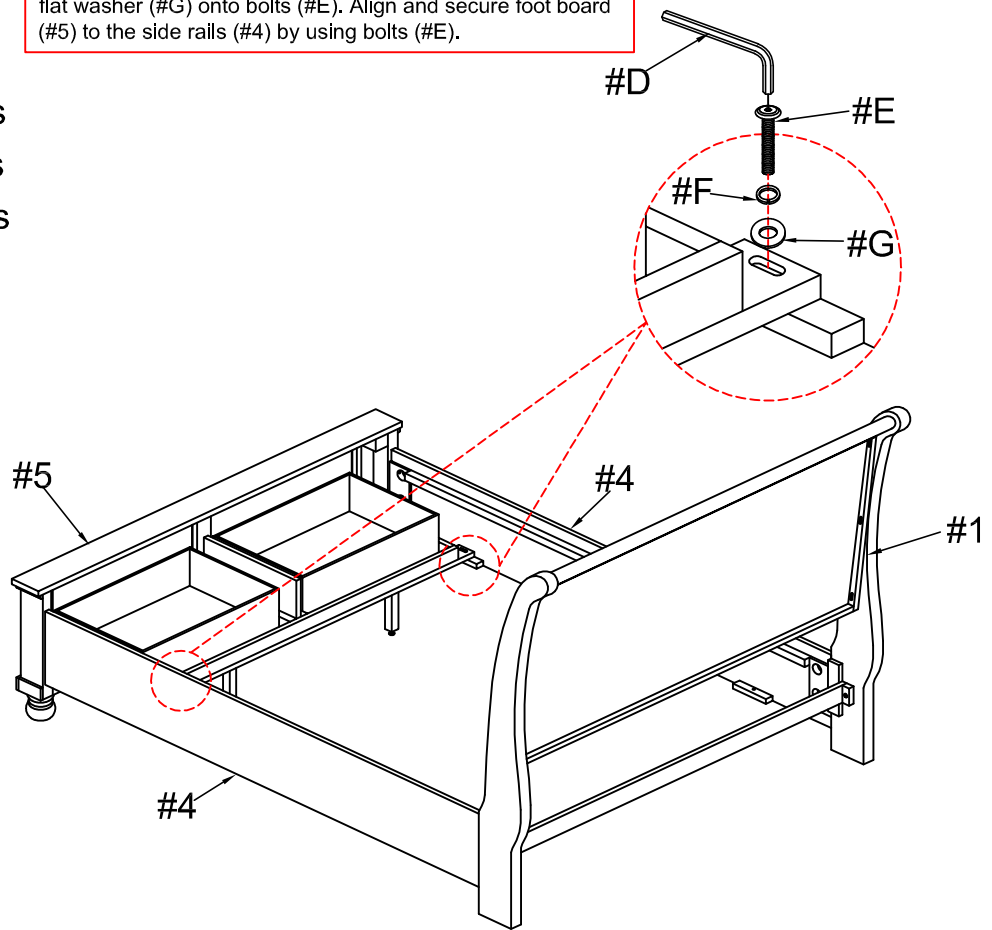

6

Part (#7) x1set

Part (#9) x8pcs

Attach support legs (#9) to the holes of the slats (#7). Adjust leveler of the support legs (#9) according to ground level.

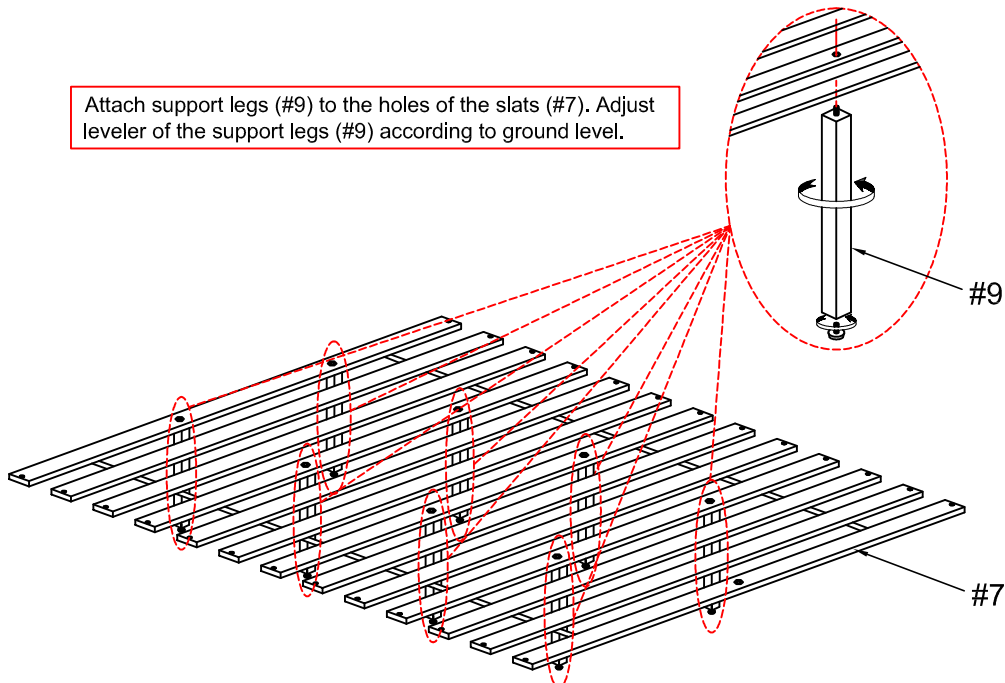

ASSEMBLY INSTRUCTIONS

7

Align slats to the side rails (#4), then secure by using screws (#H).

Hardware (#H) x26pcs

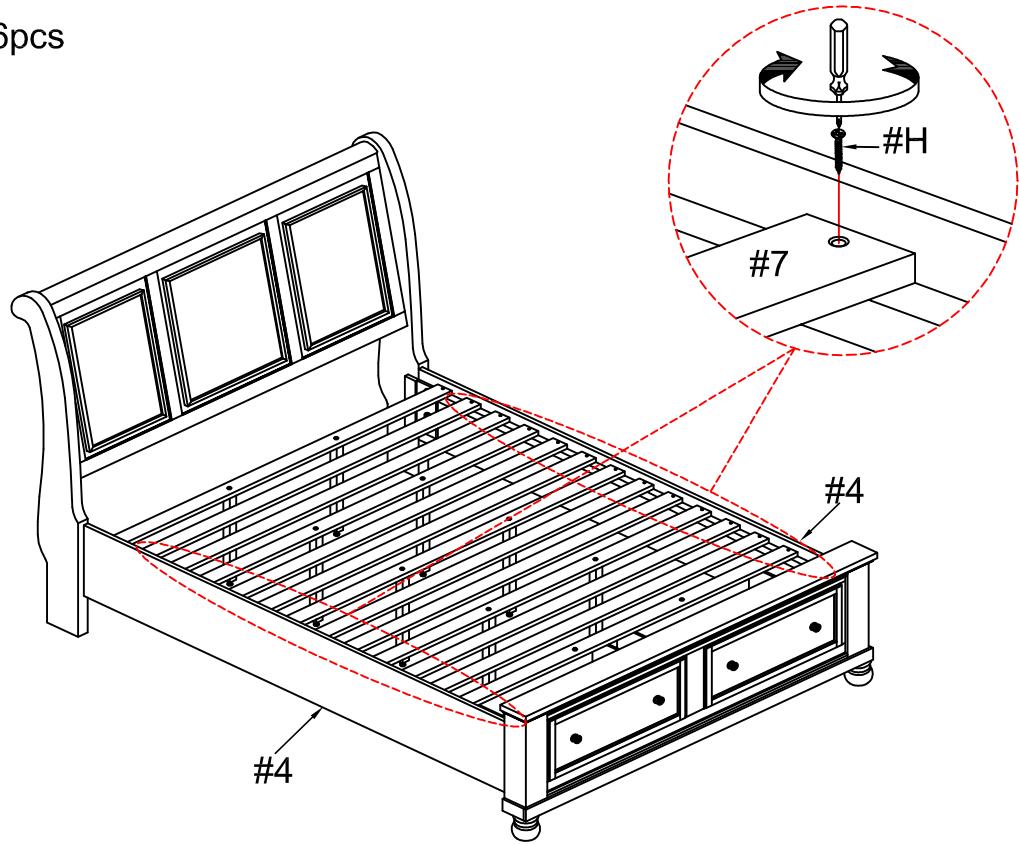

8

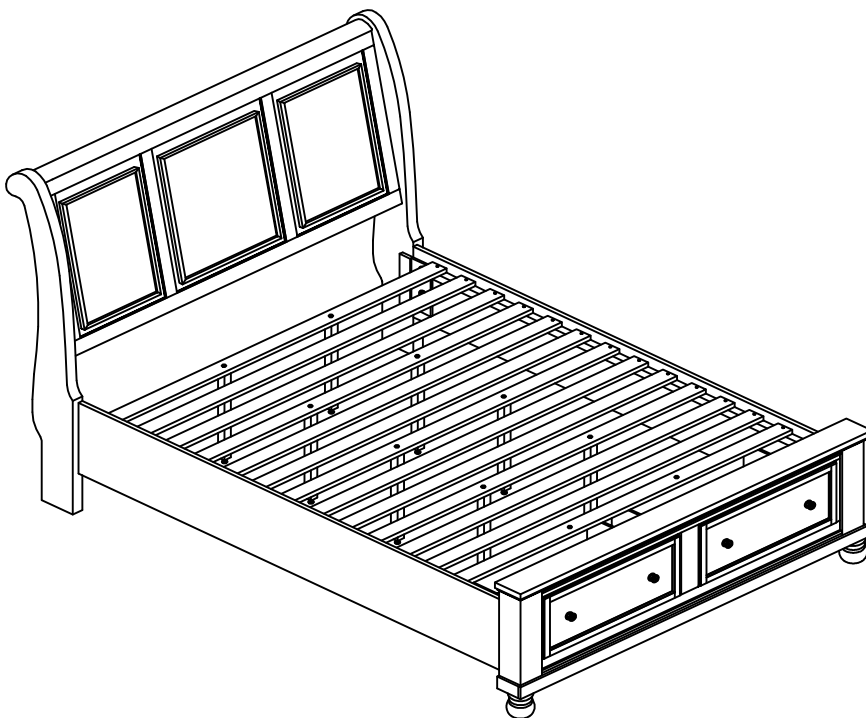

ASSEMBLY COMPLETED



Please ensure the furniture rests on an even and flat surface. If the product wobbles or feels loose, double-check all bolts and/or screws are properly tightened and secured.



Keep this handy!

Please retain this instruction manual and any order-related information for future reference.



Lift, don't drag!

To avoid damage to product please always LIFT the product when transporting or adjusting the placement.