

ASSEMBLY INSTRUCTIONS

MODEL #

CM7365Q

Questions?

GIVE US CALL: 1-888-980-5122
MON-FRI 8:30AM - 5:30PM (PST)

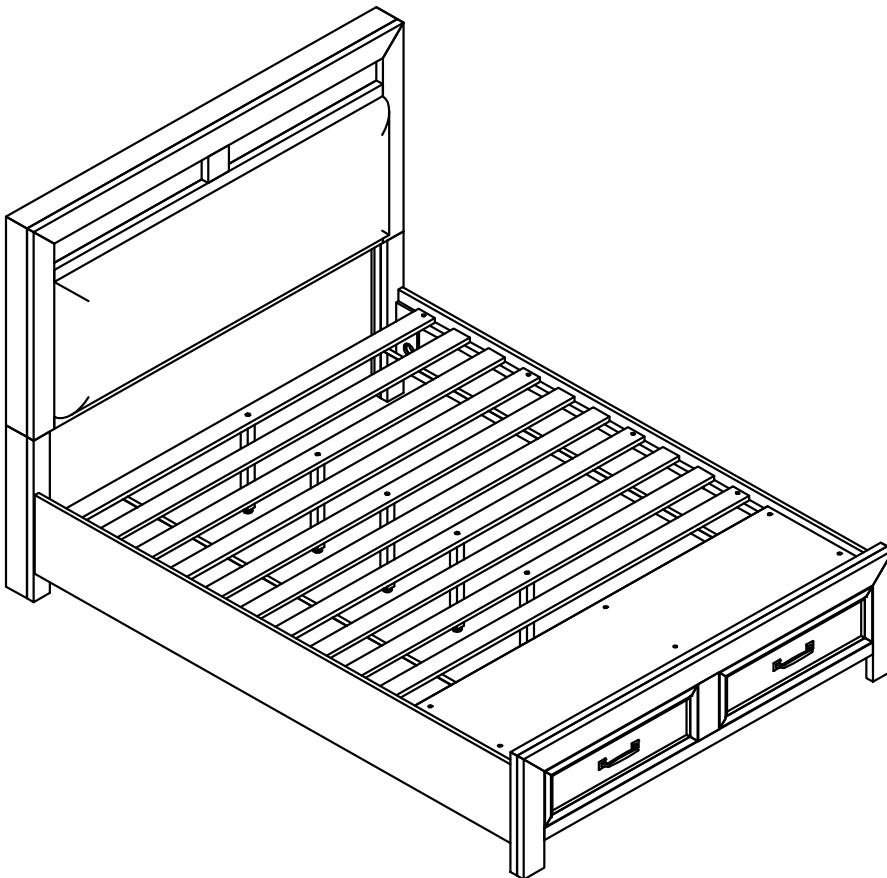

TOOLS REQUIRED



Allen Wrench
(Included)



Phillips
Screwdriver
(Not Included)

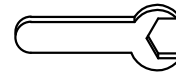

Wrench 12mm
(Included)



3 - People
Recommended

ASSEMBLY RATING



EASY —————> DIFFICULT

The Assembly Rating is a 5-point system showing the level of effort needed to assemble a specific product.



FOA Intro

Thank you for your purchase!

We hope you enjoy this new addition to your home for many years to come.

Our commitment to providing quality products does not simply end when you purchase our product. We fully stand behind our products from start to finish. Our customer service department is available Monday – Friday 8:30 AM – 5:30 PM Pacific and can help with assembly questions as well as, if necessary, replacing damaged or missing parts. To help expedite our service, please have these assembly instructions readily available, along with your order receipt.

 **Consumer Hotline**
Toll-Free 1-888-980-5122

 **Monday to Friday**
8:30AM- 5:30PM (PST)

 **WEBSITE**
www.foagroup.com

 **E-MAIL**
cs.ec@foagroup.com

    foagroup

 FurnitureOfAmerica

CHECK BEFORE STARTING

Are you missing anything?

Double-check all parts, hardware and accessories listed on Page 6 are accounted for.

Check out our Quick Tips!

We recommend reviewing the pre-assembly handouts. Even experts need a refresher now and then!

Should we send any replacements?

Are there any irregularities or flaws in the parts? We can send replacements!

Prep Time!

Please review the assembly instructions and all diagrams prior to assembling. Arrange parts as recommended on Page 7 and group identical hardware together to make assembling easier.

PRE ASSEMBLY INTRODUCTION

We understand building ready-to-assemble furniture can be a challenging experience for some. To help avoid confusion, we have provided some helpful tips that may speed up the process.



Teamwork

ALWAYS have at least two people to help with transporting and assembling the product to avoid potential injury and/or damage.



Suitable Location

Assembling near the area of the intended location is highly recommended.



Sufficient Space

Make sure you have enough space to move around during the assembly.

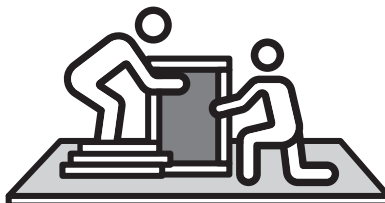

Avoid Scratches

Use cardboard, blankets or a carpeted area while assembling furniture to prevent scratches.



Flat Surface

Make sure the furniture rests on a flat and level surface with each leg evenly touching the floor.

ASSEMBLY AND CARE ADVICE



FAILURE TO FOLLOW THE GUIDELINES BELOW MAY RESULT IN INJURY AND/OR PROPERTY DAMAGE.



Position each part correctly and insert screws or bolts into their respective holes.



Turn clockwise to tighten and only tighten when step is completed or when instructed to do so.



Use the appropriate hand tools or power tools for assembly. Select steps, such as tightening screws and/or bolts, may require hand tools to avoid causing damage during assembly.



Save the instructions and store any supplied tools for later maintenance.



After two weeks, check and tighten any loose hardware and repeat again every six months thereafter.

IT IS THE USER'S RESPONSIBILITY TO MAINTAIN THE FURNITURE. THE HARDWARE MAY LOOSEN OVER TIME AND MAY CAUSE THE FURNITURE TO BE WOBBLY AND UNABLE TO SUPPORT ITS INTENDED WEIGHT CAPACITY. THIS MAY LEAD TO COLLAPSE AND MAY CAUSE SERIOUS INJURY.

BED

CM7365Q

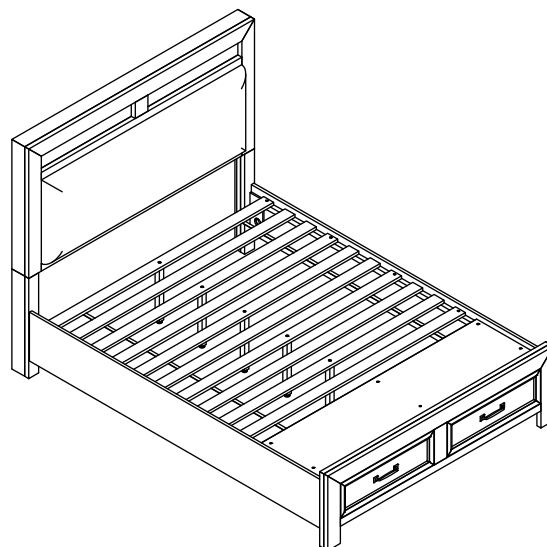

- Please keep instructions for future reference.
- Check the quantity and irregularity of parts and hardware before you start.

PARTS

#1 1pc

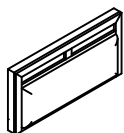

Headboard

#2 2pcs

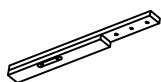

Headboard Leg (L&R)

#3 2pcs

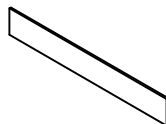

Rail

#4 1pc

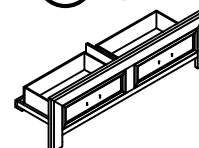

Storage Footboard

#5 1Set

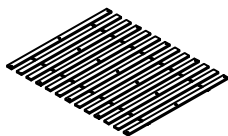

Slat 13pcs

#6 2pcs

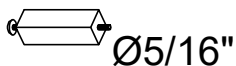

Drawer Support Leg
120x30x30mm

#7 6pcs



Slat Support Leg
365x30x30mm

#8 1pc

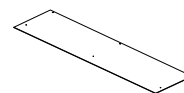

Dusty Panel

HARDWARE

#A 6pcs



Bolt 5/16" x 1-3/8"

#B 14pcs



Lock washer
Ø5/16"

#C 14pcs



Flat washer
Ø5/16

#D 1pc



Allen wrench M4

#E 8pcs



Thread Rod
Ø5/16" x 3-1/2"

#F 8pcs



Half Moon Washer
Ø5/16"

#G 8pcs

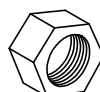

Hex Nut
Ø5/16"

#H 1pc

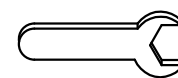

Wrench 12mm

HARDWARE

Ⓢ10pcs

Ⓢ6pcs



Screw #4 x 30mm







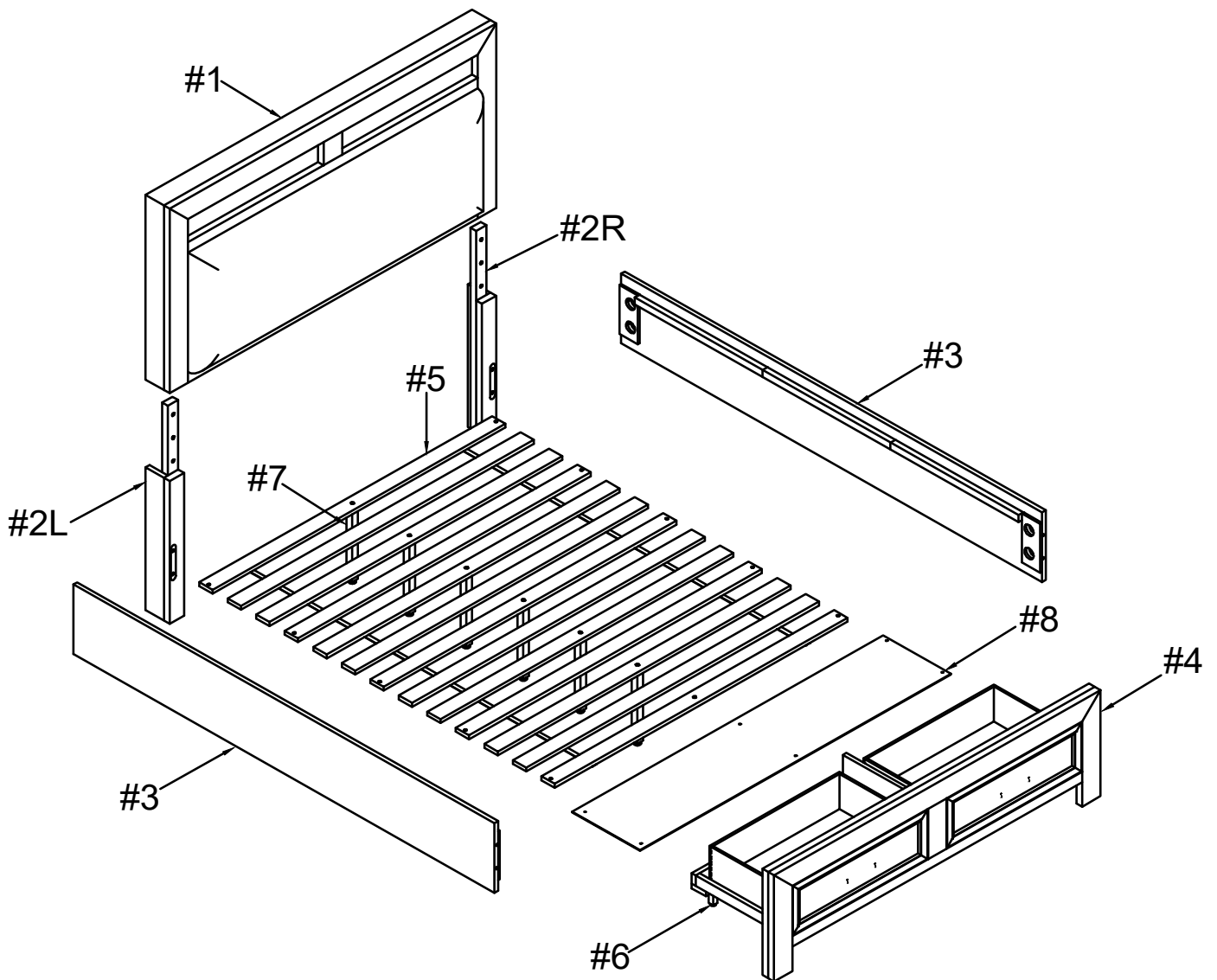



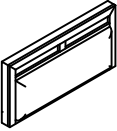
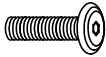

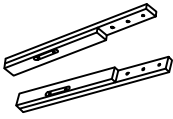

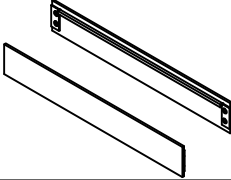

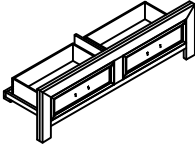
Screw #4 x 10mm

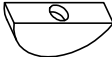
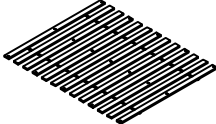
Exploded View

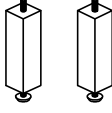

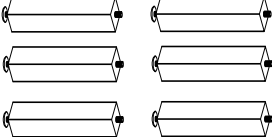
CM7365Q is packed in 3 cases

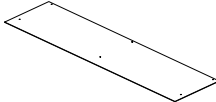
Carton	Disignation	Part		Hardware
CM7365Q-HB	Headboard	#1		 #A x 6pcs  #B x 6pcs
	Headboard Leg (L&R)	#2		 #C x 6pcs  #D x 1pc
CM7365Q-R	Rail	#3		CM7365Q-R  #B x 8pcs  #C x 8pcs
CM7365Q-FB	Storage Footboard	#4		 #E x 8pcs  #F x 8pcs
	Slat 13pcs	#5		 #G x 8pcs  #H x 1pc
	Drawer Support Leg 120x30x30mm	#6		CM7365Q-FB  #I x 10pcs
	Slat Support Leg 365x30x30mm	#7		 #J x 6pcs
	Dusty Panel	#8		

ASSEMBLY INSTRUCTIONS

1

Align HB legs (#2R/L) to the headboard (#1), then secure by using bolts (#A) with washers (#B,C).

- Part #1 x1pc
- Part #2 x2pcs
- Hardware #A x6pcs
- Hardware #B x6pcs
- Hardware #C x6pcs

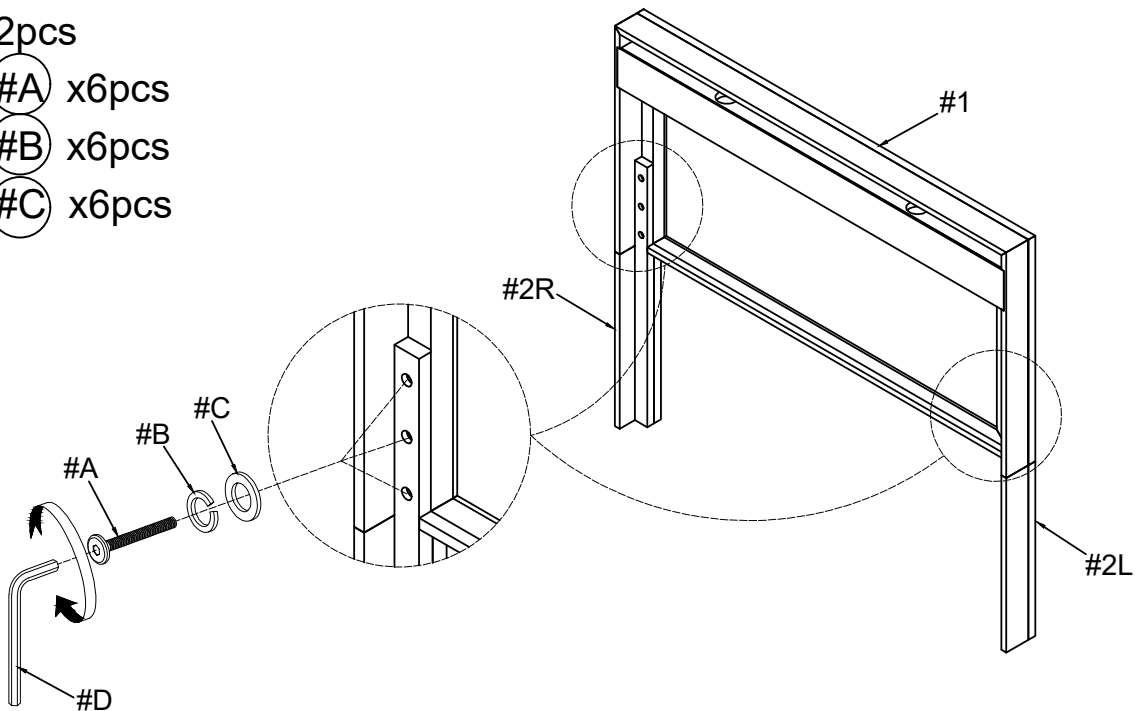

2

Attach support legs (#6) to the footboard (#4).
Adjust the leveler on the support legs (#6) according to ground level.

- Part #4 x1pc
- Part #6 x2pcs

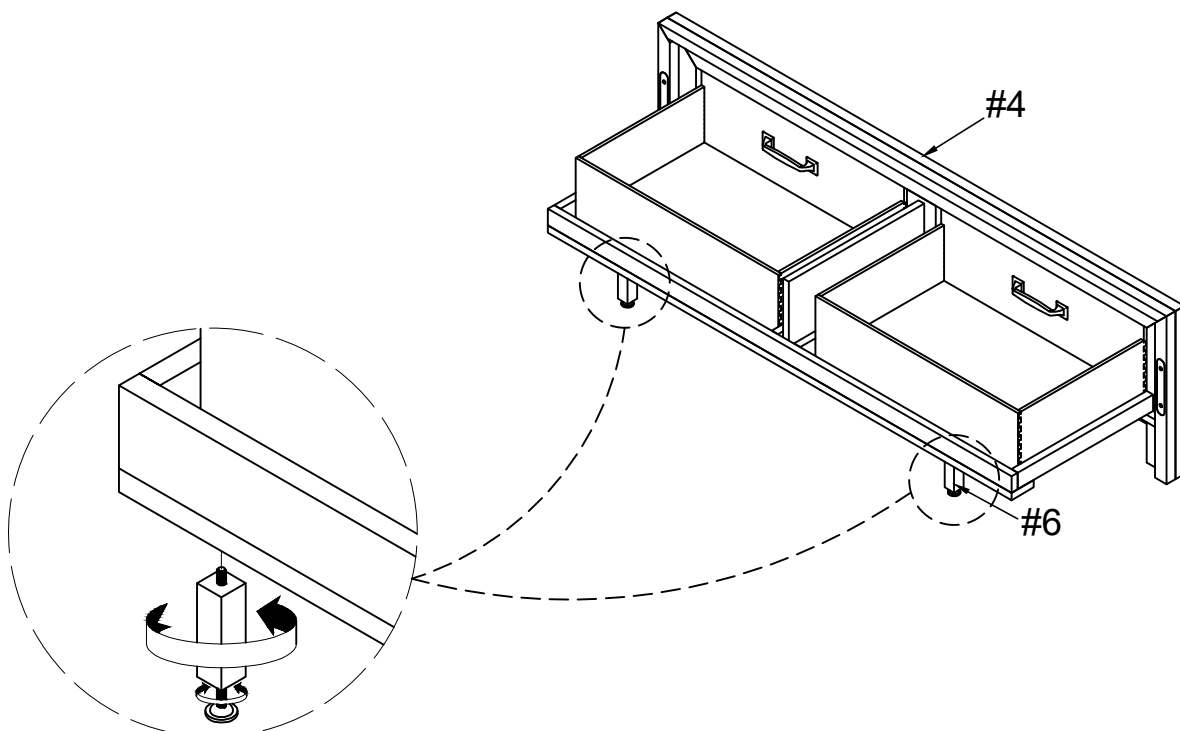

ASSEMBLY INSTRUCTIONS

3

Attach threaded bolts (#E) to the headboard (#1) and footboard (#4), then align side rails (#3) to the threaded bolts (#E) of the headboard (#1) and footboard (#4). Secure by using half moon washers (#F), washers (#B,C), and hex nuts (#G).

Part #3 x2pcs

Hardware #B x8pcs

Hardware #C x8pcs

Hardware #E x8pcs

Hardware #F x8pcs

Hardware #G x8pcs

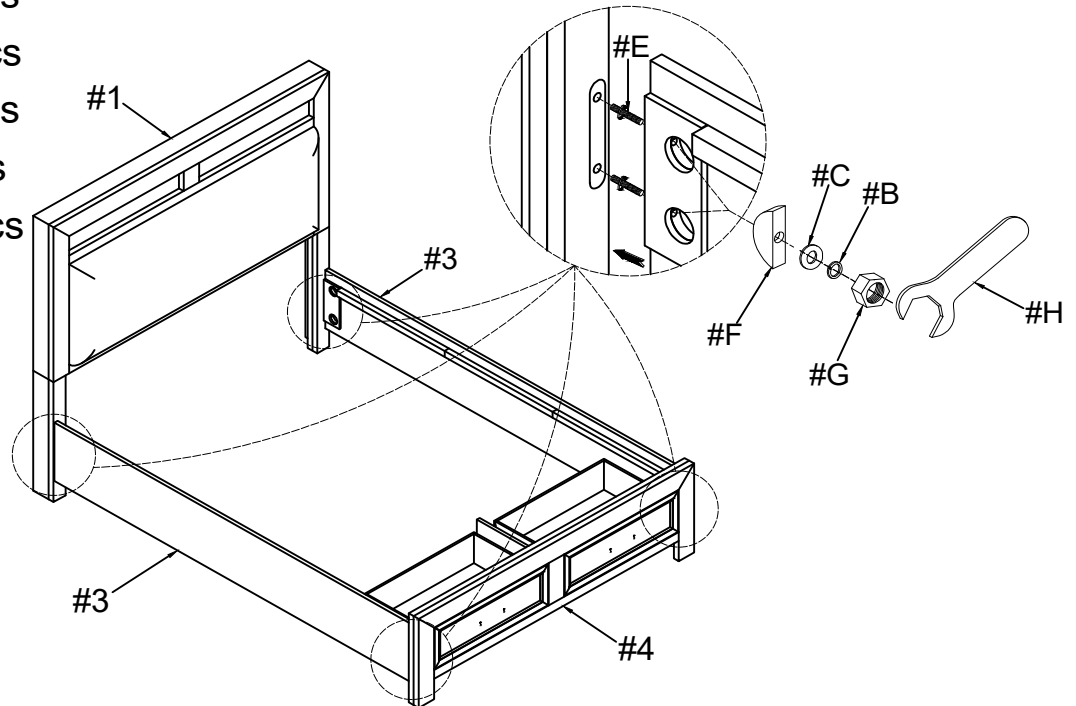

4

Part #5 x1Set

Part #7 x6pcs

Attach support legs (#7) to the slat kit (#5), then adjust levelers on the support legs (#7) according to ground level.

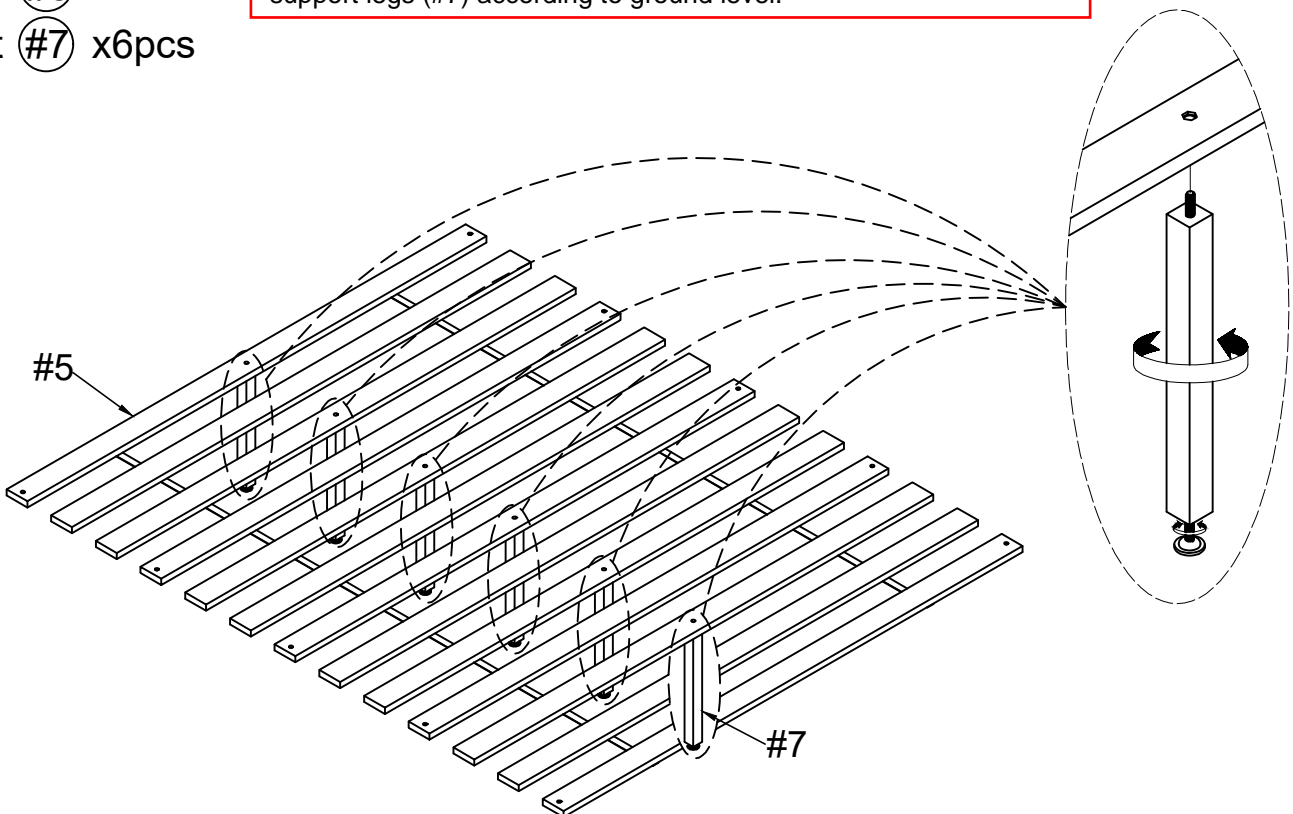

ASSEMBLY INSTRUCTIONS

5

Hardware (#I) x10pcs

Align slat kit (#5) to the side rails (#3), then secure by using screws (#I).

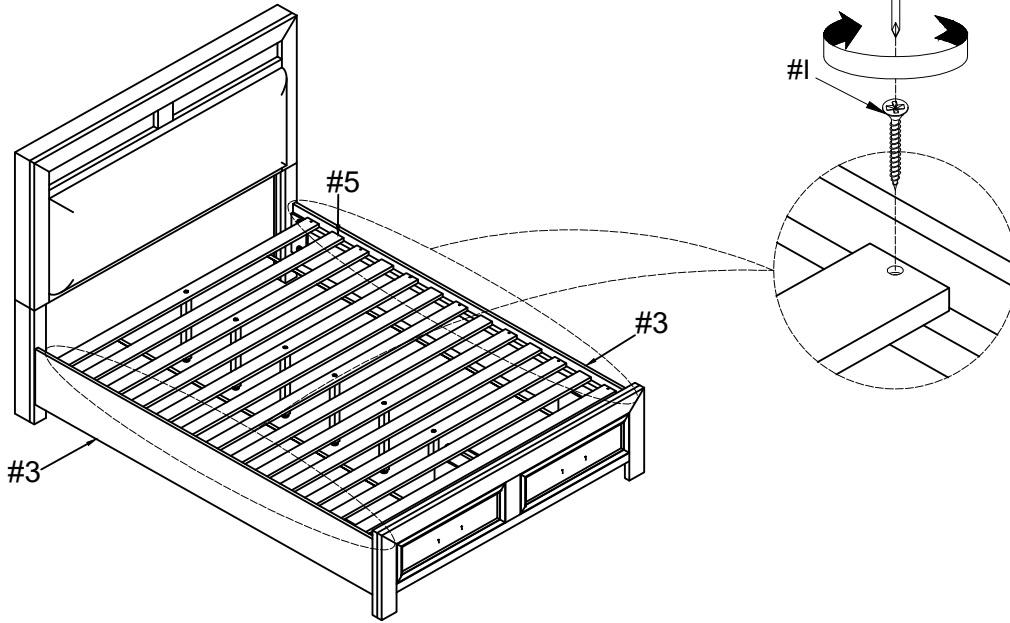

6

Part (#8) x1pc

Hardware (#J) x6pcs

Place dusty panel (#8) to the bottom end of the slats (#5), then secure by using screws (#J).

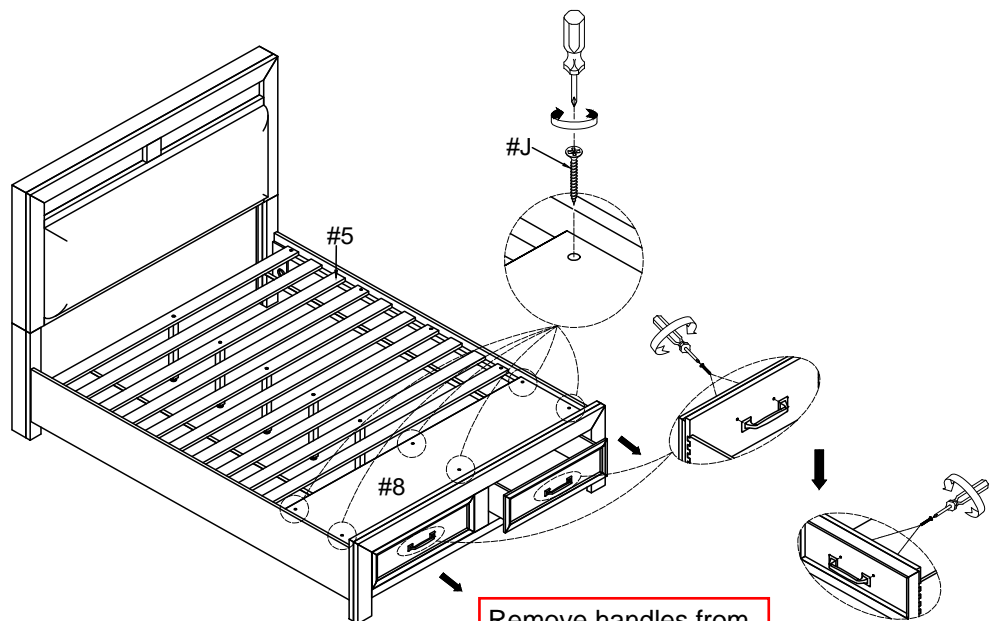

Remove handles from the inside of drawers, then secure handles to the outside of drawers.

ASSEMBLY INSTRUCTIONS

7

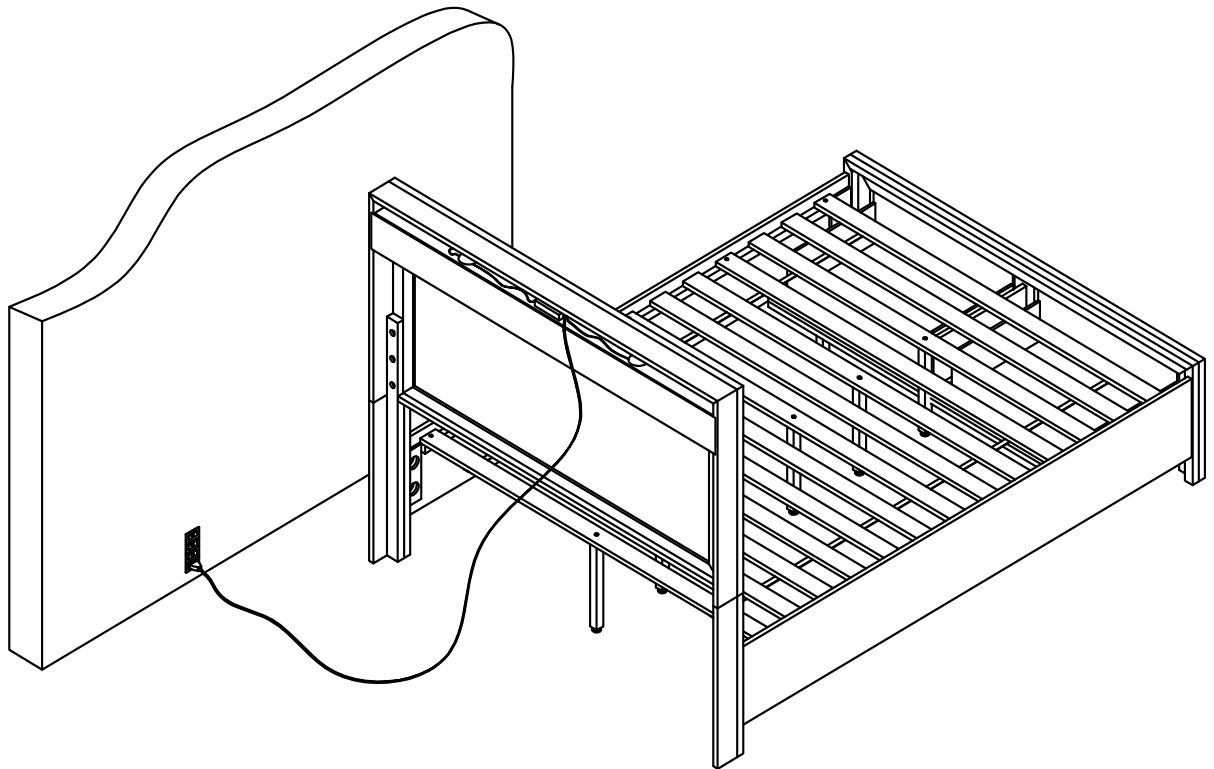

8

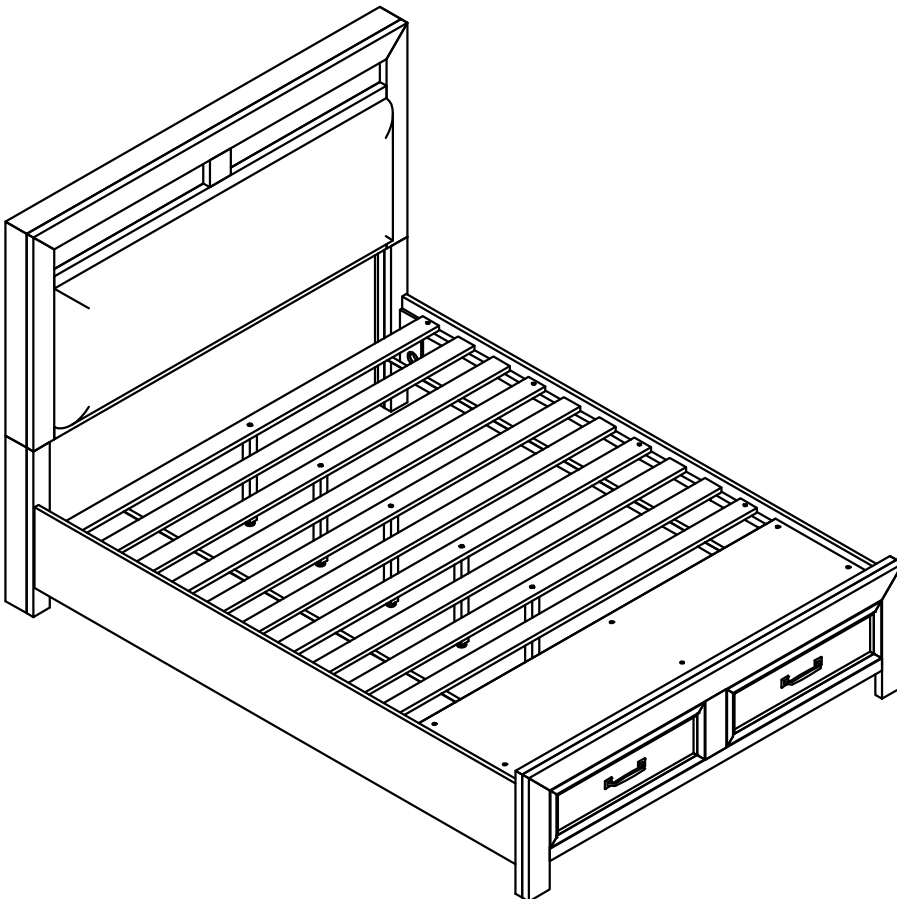

ASSEMBLY COMPLETED



Please ensure the furniture rests on an even and flat surface. If the product wobbles or feels loose, double-check all bolts and/or screws are properly tightened and secured.



Keep this handy!

Please retain this instruction manual and any order-related information for future reference.



Lift, don't drag!

To avoid damage to product please always LIFT the product when transporting or adjusting the placement.