

Furniture of America[®]

Assembly Instructions

For more information contact our team: service.ec@foagroup.com

CM7303Q/EK/CK

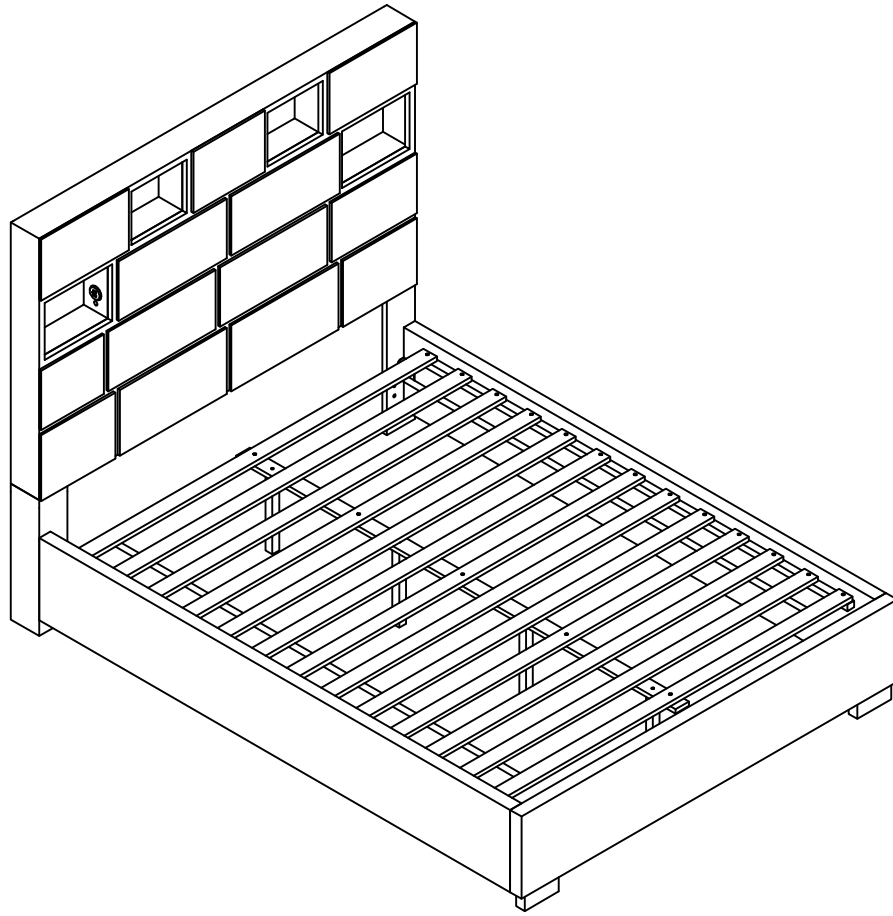

ASSEMBLY RATING

The Assembly Rating is a 5-point system that shows the degree of effort needed in assembling a specific product (with 1 being easy and 5 being difficult). For some products, two persons are recommended.

EASY  DIFFICULT

Tools Required For Assembly:

Allen Wrench

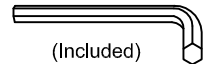

Phillips Screwdriver

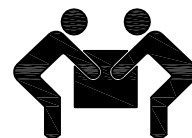
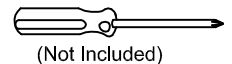

2 PERSONS RECOMMENDED

ASSEMBLY & CARE ADVICE

FOR YOUR FURNITURE TO LAST, CORRECT ASSEMBLY AND PROPER MAINTENANCE ARE NECESSARY. PLEASE FOLLOW THE INFORMATION PROVIDED BELOW TO FULLY ENJOY YOUR FURNITURE.

BASIC ASSEMBLY TECHNIQUES

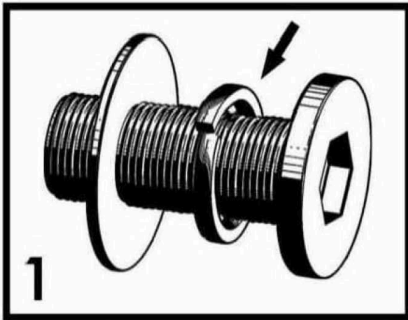

When lock or spring washer is used in an assembly, please make sure the lock or spring washer is placed between the larger flat washer and the head of the screw or bolt.

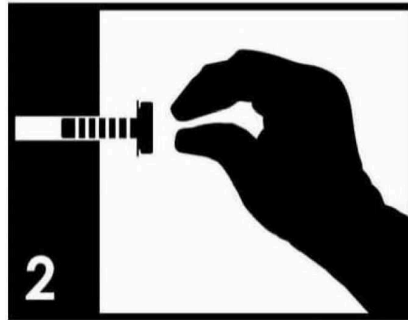

Position each part correctly and insert screws or bolts into their respective holes by hand tighten or using the proper hand tool. Only tighten when step is completed or when instructed to do so.

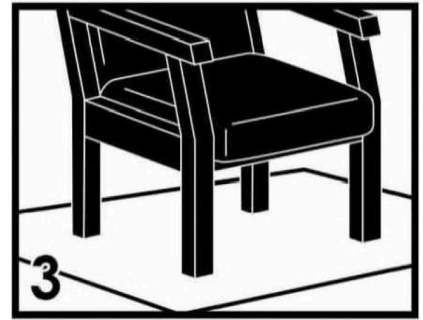

Use cardboard or carpet area when assembling furniture to prevent scratches. Make sure the furniture rests on a flat and level surface with each leg evenly touching the floor.

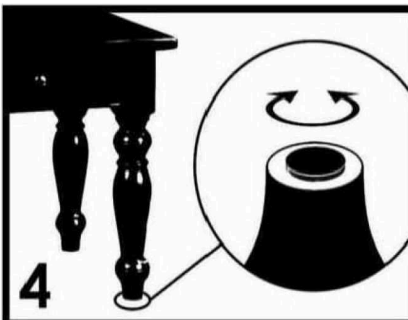

Some furniture comes with height adjustment knobs underneath each leg. To lower or to raise each leg, you need to turn clockwise or counterclockwise, respectively.

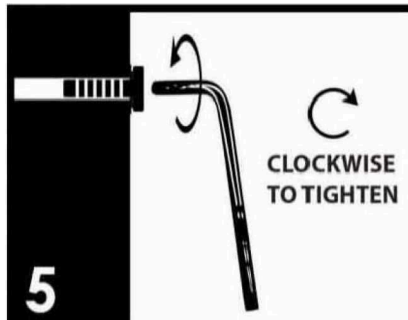

Make sure all parts are properly aligned, then use the appropriate hand tool to completely tighten the bolts or screws. Do not use power tools and do not overtighten.

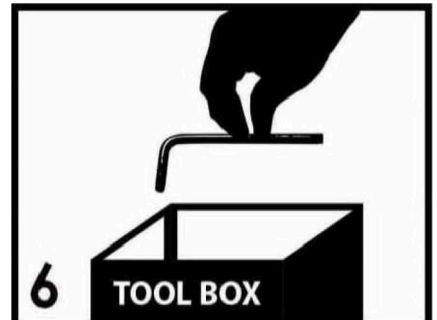

Save the instructions and store the Allen wrench or any supplied tool for later maintenance. After two weeks, check and tighten any loose hardware and repeat again every six months thereafter.

IT IS THE USER'S RESPONSIBILITY TO MAINTAIN THE FURNITURE. THE HARDWARE MAY LOOSEN OVER TIME AND MAY CAUSE THE FURNITURE TO BE WOBBLY AND UNABLE TO SUPPORT ITS INTENDED WEIGHT CAPACITY. THIS MAY LEAD TO COLLAPSE AND MAY CAUSE SERIOUS INJURY.

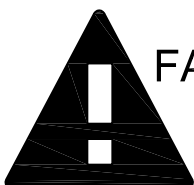

FAILURE TO FOLLOW THE GUIDELINES ABOVE MAY RESULT IN INJURY AND/OR PROPERTY DAMAGE.

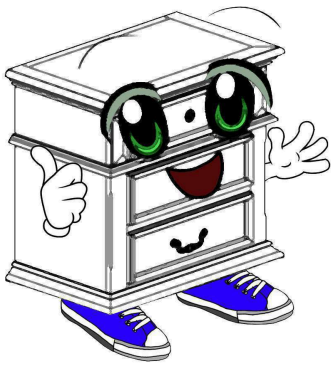

Before you begin, please read Page 2 of "Assembly and Care Advice".

And remember, do not tighten until each step is completed or instructed.

Parts List

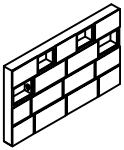

#1 x 1pc
Headboard Panel

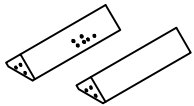

#2 x 2pcs
Headboard Leg (L&R)

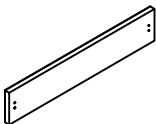

#3 x 1pc
Footboard



#4 x 2pcs
Bun Feet

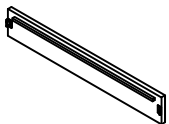

#5 x 2pcs
Side Rails

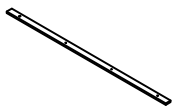

#6 x 1pc
Slat Center Support

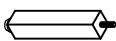

#7 x 4pcs $\varnothing 1/4$
Support Leg 303x30x30mm

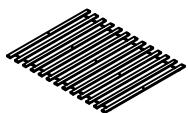

#8 x 1Set
Bed Slat 13pcs

Hardware List



#A x 10pcs
Bolt $\varnothing 5/16$ " x 2-3/8"



#B x 18pcs
Lock Washer $\varnothing 5/16$ "



#C x 18pcs
Flat Washer $\varnothing 5/16$ "



#D x 8pcs
Bolt $\varnothing 5/16$ " x 1-3/16"

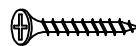

#E x 31pcs
Screw #4 x 1-1/4"



#F x 1pc
Allen Wrench M4

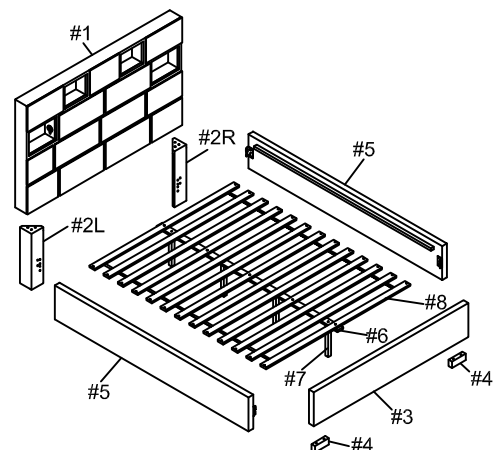



#1

Back view

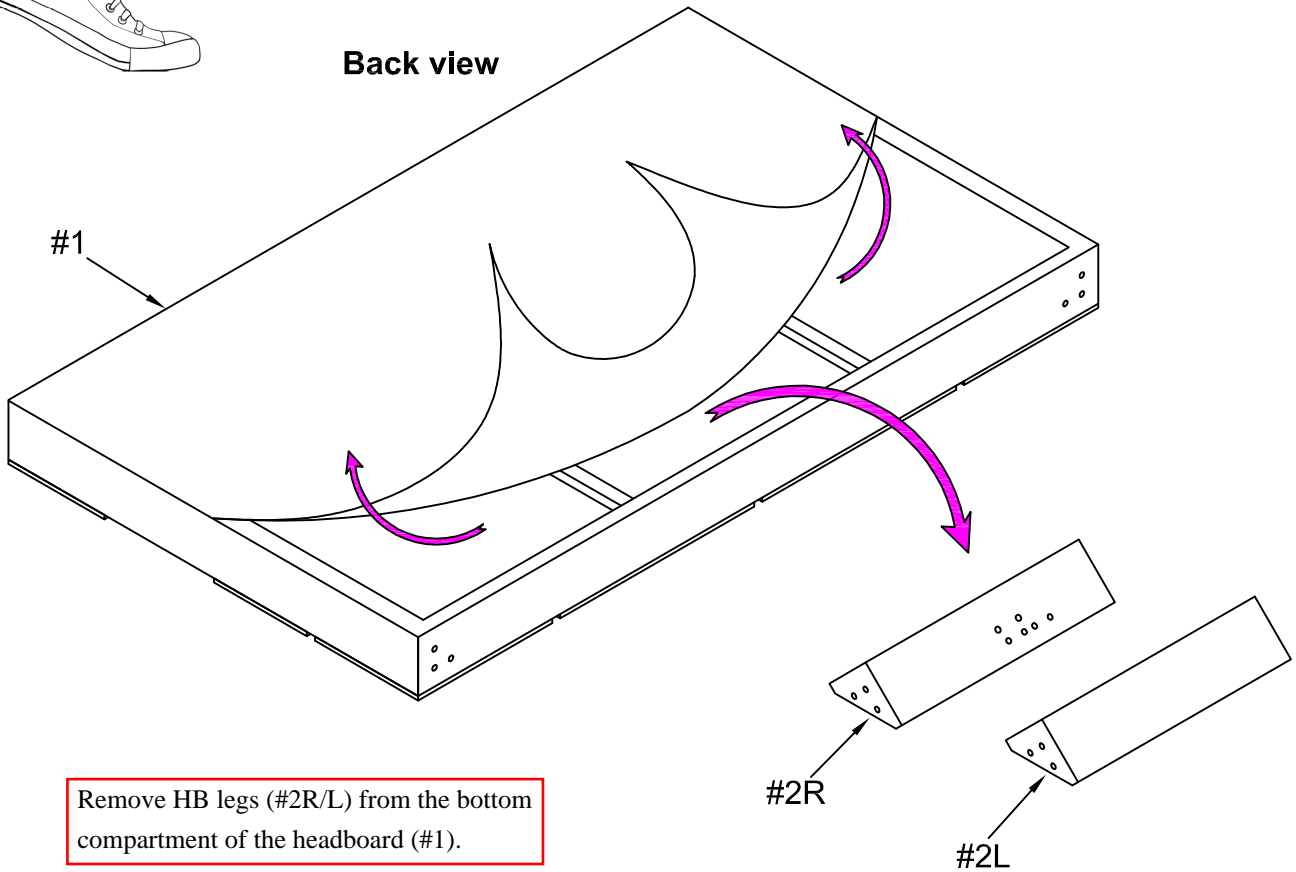

Remove HB legs (#2R/L) from the bottom compartment of the headboard (#1).



#2

Back view

A x 6pcs
 # B x 6pcs
 # C x 6pcs

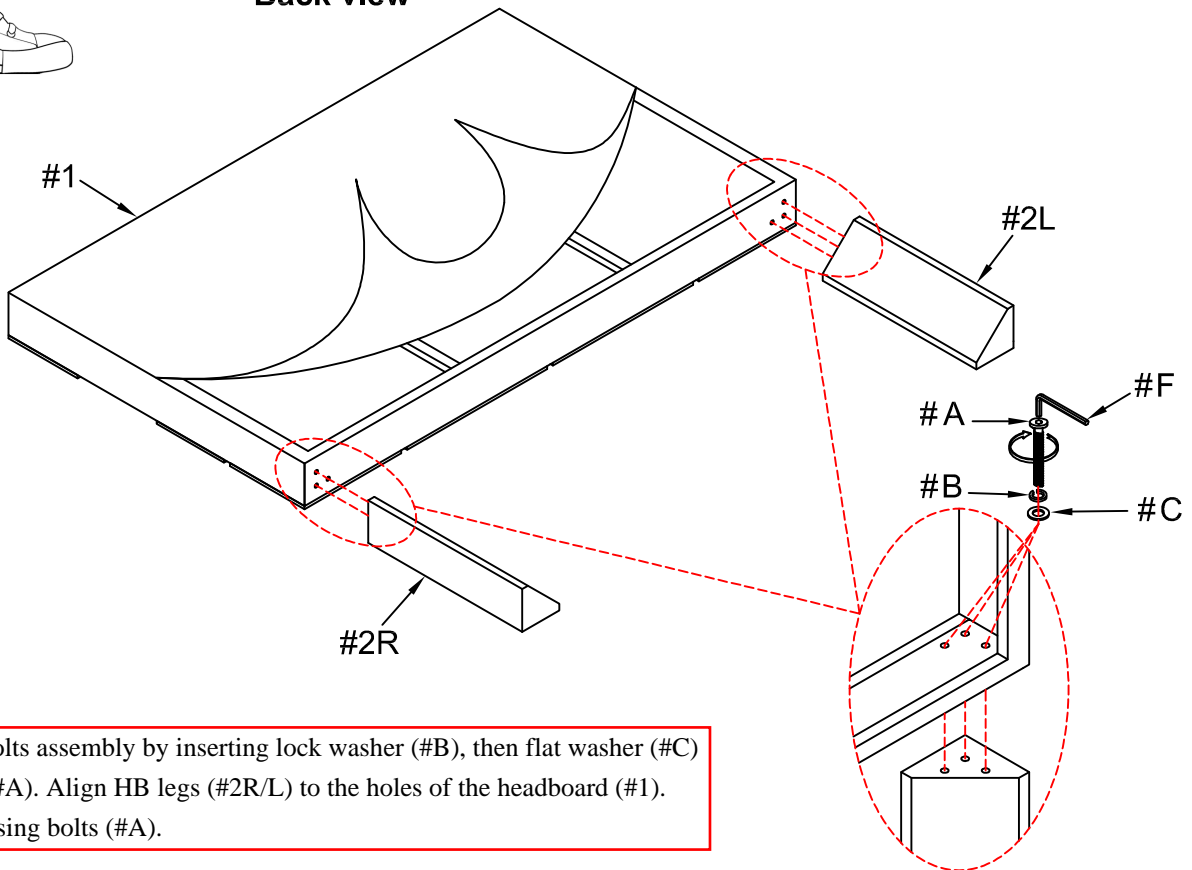

Prepare 6 bolts assembly by inserting lock washer (#B), then flat washer (#C) onto bolts (#A). Align HB legs (#2R/L) to the holes of the headboard (#1). Secure by using bolts (#A).



A x 4pcs
 # B x 4pcs
 # C x 4pcs

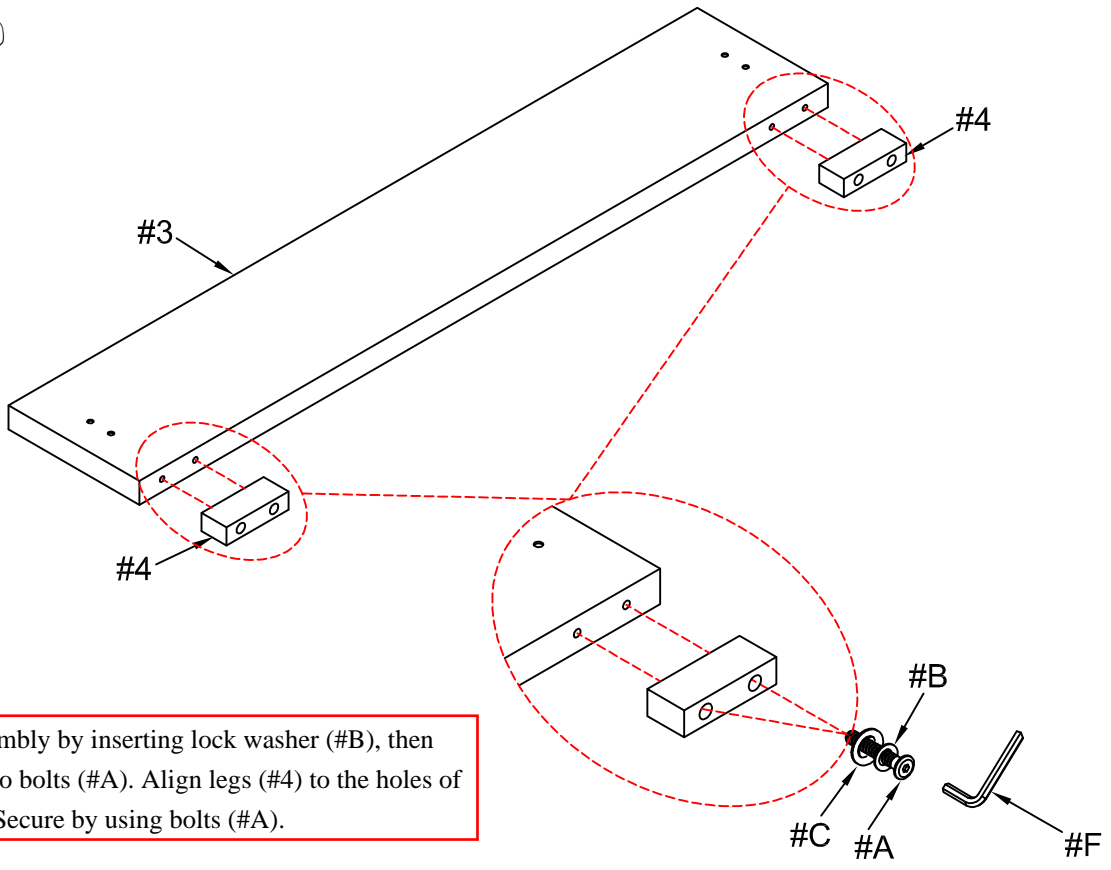

Prepare 4 bolts assembly by inserting lock washer (#B), then flat washer (#C) onto bolts (#A). Align legs (#4) to the holes of the footboard (#3). Secure by using bolts (#A).



B x 8pcs
 # C x 8pcs
 # D x 8pcs

Prepare 8 bolts assembly by inserting lock washer (#B), then flat washer (#C) onto bolts (#D). Attach bolts (#D) half way into the headboard (#1) and footboard (#3) holes. Rest the hooks of the side rails (#5) to bolts (#D). Secure by tightening bolts (#D).

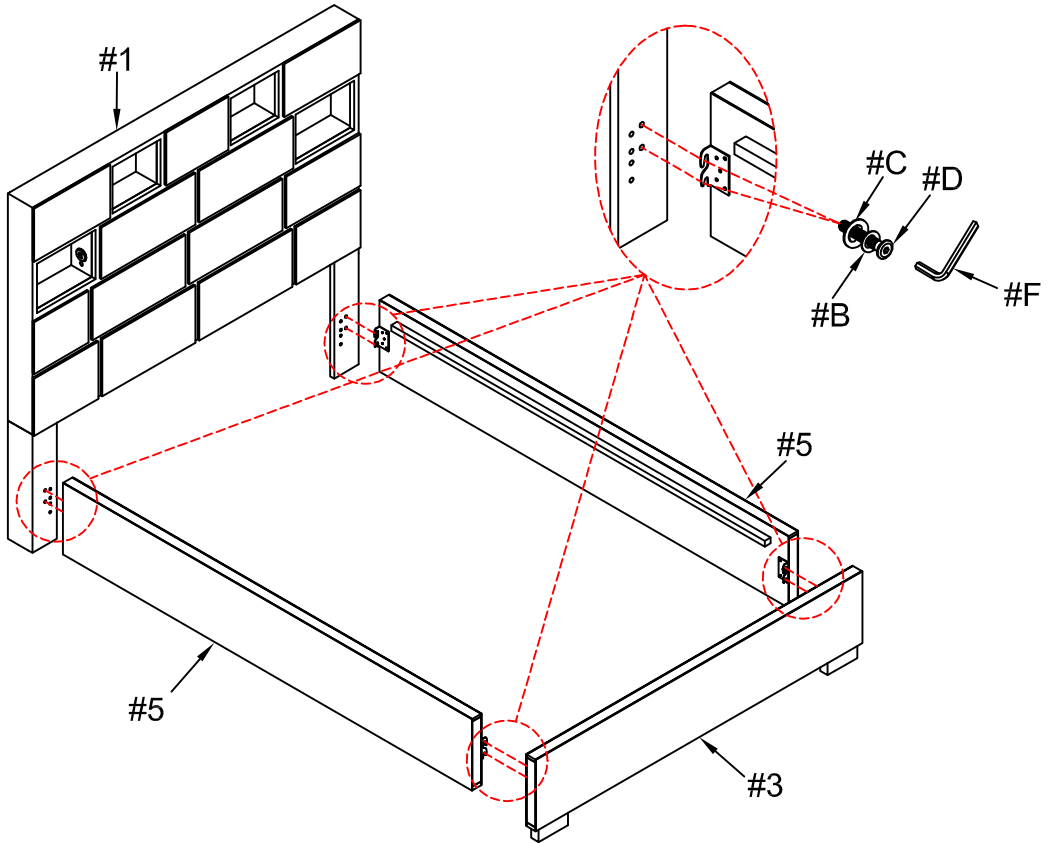



Attach support legs (#7) to the holes of the slat center support (#6), then adjust the floor leveler of the support legs according to ground level.

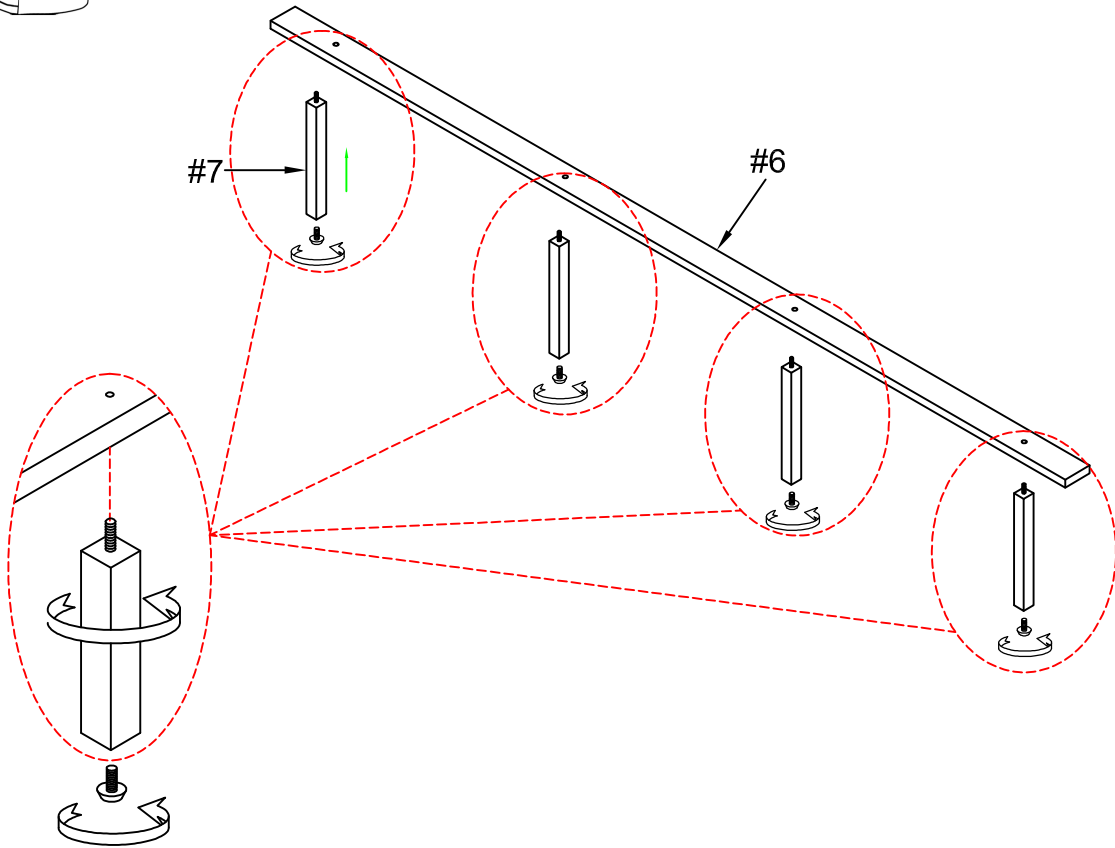

Align the bed slats (#8) to the side rails (#5) and center support (#6). Secure by using screws (#E).

#E x 31pcs

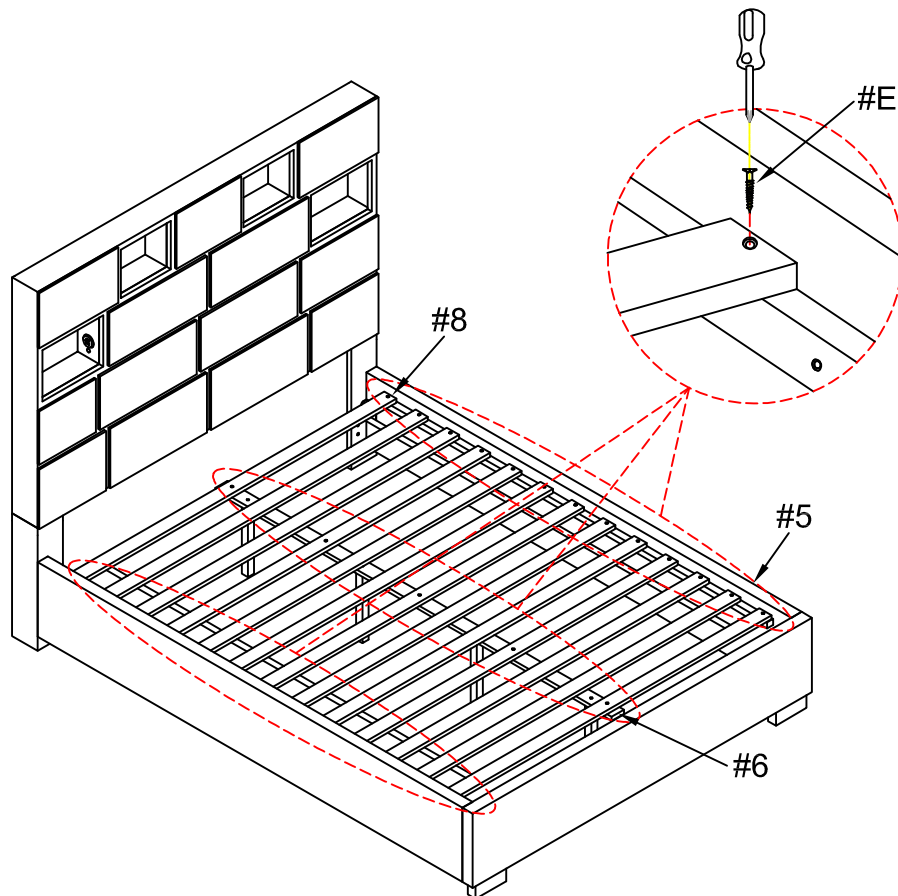

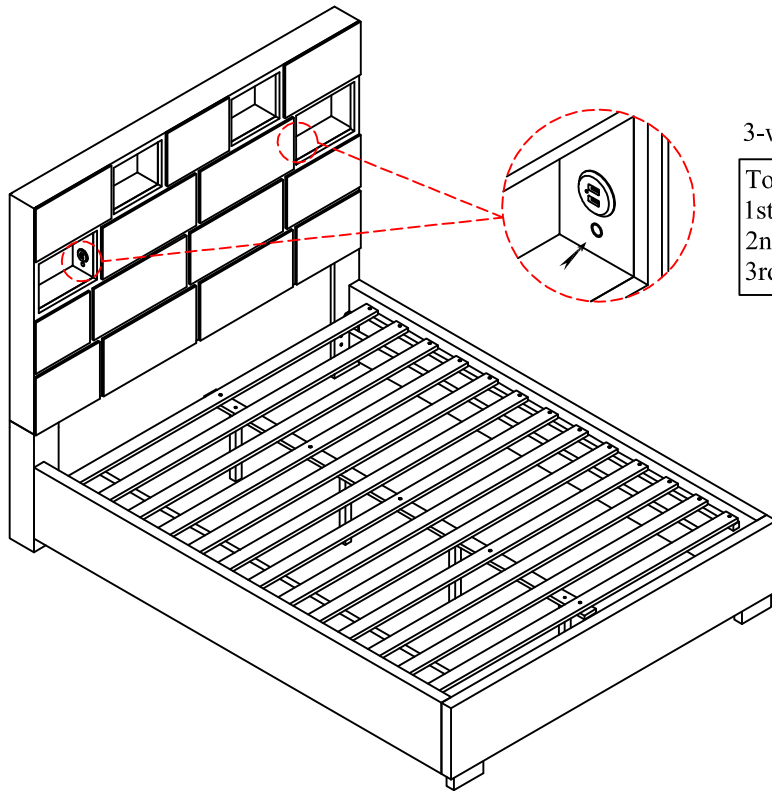

3-way touch switch

Touch light switch.
1st. touch dim light
2nd. touch bright light
3rd. touch light off

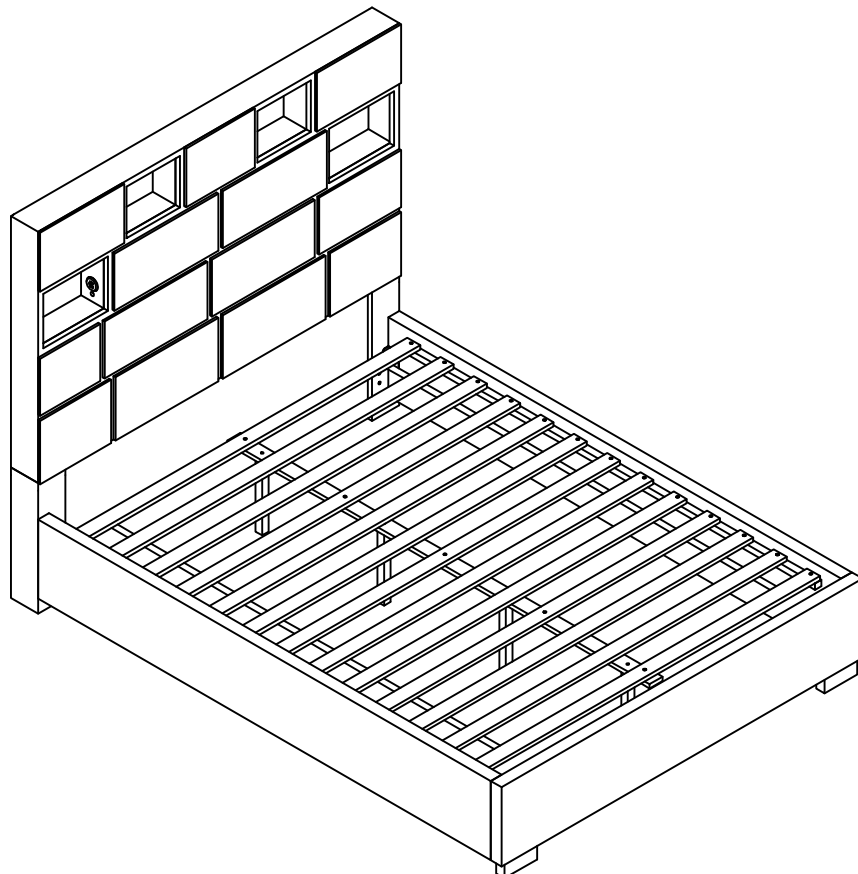

ASSEMBLY IS COMPLETED