

ASSEMBLY INSTRUCTIONS

MODEL #

**CM7271EK
CM7271CK**

Questions?

GIVE US CALL: 1-888-980-5122
MON-FRI 8:30AM - 5:30PM (PST)

TOOLS REQUIRED



Allen Wrench

(Included)



Phillips
Screwdriver

(Not Included)

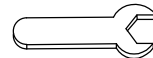

Wrench

(Included)

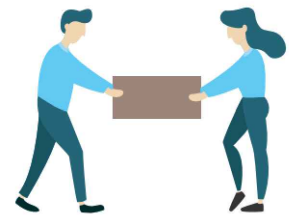

3 - People
Recommended

ASSEMBLY RATING



EASY —————> DIFFICULT

The Assembly Rating is a 5-point system showing the level of effort needed to assemble a specific product.



FOA Intro

Thank you for your purchase!

We hope you enjoy this new addition to your home for many years to come.

Our commitment to providing quality products does not simply end when you purchase our product. We fully stand behind our products from start to finish. Our customer service department is available Monday – Friday 8:30 AM – 5:30 PM Pacific and can help with assembly questions as well as, if necessary, replacing damaged or missing parts. To help expedite our service, please have these assembly instructions readily available, along with your order receipt.

 **Consumer Hotline**
Toll-Free 1-888-980-5122

 **Monday to Friday**
8:30AM- 5:30PM (PST)

 **WEBSITE**
www.foagroup.com

 **E-MAIL**
cs.ec@foagroup.com

    foagroup

 FurnitureOfAmerica

CHECK BEFORE STARTING

Are you missing anything?

Double-check all parts, hardware and accessories listed on Page 6 are accounted for.

Check out our Quick Tips!

We recommend reviewing the pre-assembly handouts. Even experts need a refresher now and then!

Should we send any replacements?

Are there any irregularities or flaws in the parts? We can send replacements!

Prep Time!

Please review the assembly instructions and all diagrams prior to assembling. Arrange parts as recommended on Page 7 and group identical hardware together to make assembling easier.

PRE ASSEMBLY INTRODUCTION

We understand building ready-to-assemble furniture can be a challenging experience for some. To help avoid confusion, we have provided some helpful tips that may speed up the process.



Teamwork

ALWAYS have at least two people to help with transporting and assembling the product to avoid potential injury and/or damage.



Suitable Location

Assembling near the area of the intended location is highly recommended.



Sufficient Space

Make sure you have enough space to move around during the assembly.



Avoid Scratches

Use cardboard, blankets or a carpeted area while assembling furniture to prevent scratches.



Flat Surface

Make sure the furniture rests on a flat and level surface with each leg evenly touching the floor.

ASSEMBLY AND CARE ADVICE



FAILURE TO FOLLOW THE GUIDELINES BELOW MAY RESULT IN INJURY AND/OR PROPERTY DAMAGE.



Position each part correctly and insert screws or bolts into their respective holes.



Turn clockwise to tighten and only tighten when step is completed or when instructed to do so.



Use the appropriate hand tools or power tools for assembly. Select steps, such as tightening screws and/or bolts, may require hand tools to avoid causing damage during assembly.



Save the instructions and store any supplied tools for later maintenance.

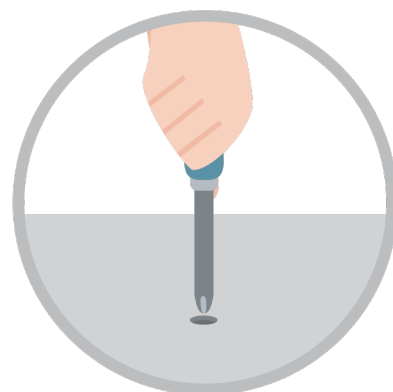

After two weeks, check and tighten any loose hardware and repeat again every six months thereafter.

IT IS THE USER'S RESPONSIBILITY TO MAINTAIN THE FURNITURE. THE HARDWARE MAY LOOSEN OVER TIME AND MAY CAUSE THE FURNITURE TO BE WOBBLY AND UNABLE TO SUPPORT ITS INTENDED WEIGHT CAPACITY. THIS MAY LEAD TO COLLAPSE AND MAY CAUSE SERIOUS INJURY.

E.KING BED

CAL.KING BED

CM7271EK/CK

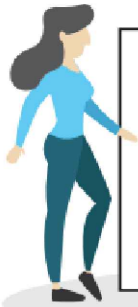

- Please keep instructions for future reference.
- Check the quantity and irregularity of parts and hardware before you start.

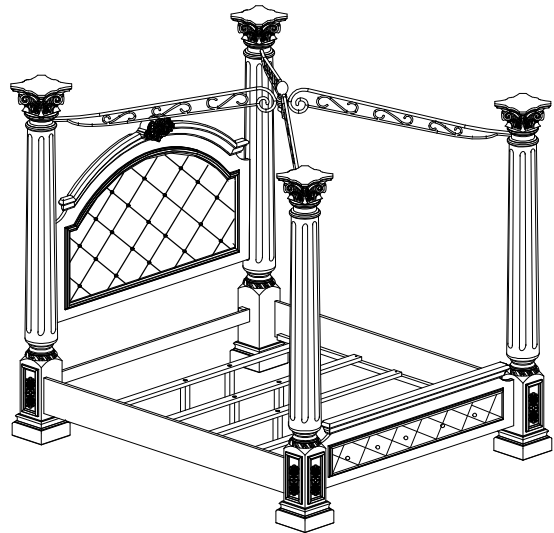

PARTS

#A 2pcs

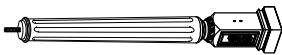

Headboard Pots
(R&L)

#B 1pc

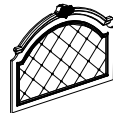

Headboard Panel

#C 1pc



Bottom Rail

#D 2pcs



Footboard Pots
(R&L)

#E 1pc

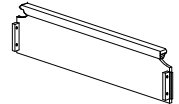

Footboard Panel

#F 2pcs



Bed Rail

#G 4pcs



Bed Slats

#H 8pcs

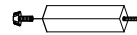

Bed Slats Support
With Leveler

#I 4pcs



Finial For Post

#J 4pcs

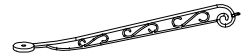

Metal Frame

#K 1pc



Mounting Plate

#L 1pc



Finial

#M 1pc



Bracket

HARDWARE

#1 14pcs

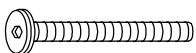

Long Bolt
Ø5/16" x 2-1/2"

#2 4pcs

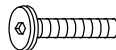

Short Bolt
Ø1/4" x 1/2"

#3 14pcs



Flat Washer
Ø5/16" x 19mm

#4 1pc



Allen Wrench
5mm

#5 8pcs



Wood Screw
#4 x 1-1/4"

#6 8pcs



Thread Bolt
Ø5/16" x 3-1/2"

#7 8 pcs



Nut Ø5/16"

#8 1pcs







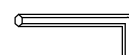









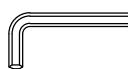
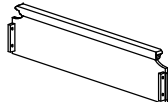

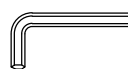
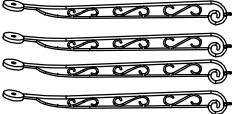
Wrench
Ø5/16"

#9 1pc

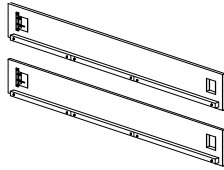
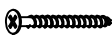

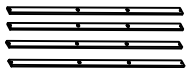
Allen Wrench
4mm

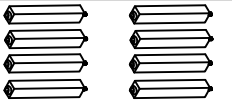
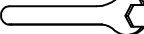
CM7271EK/CK is packed in 6 cases

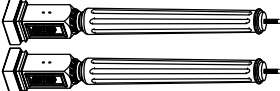
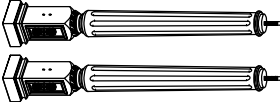
Carton	Disignation	Part		Hardware
CM7271EK/CK- 1	Headboard Panel	#B		 #1 14pcs
	Bottom Rail	#C		 #3 14pcs  #4 1pc
CM7271EK/CK- 2	Footboard Panel	#E		 #2 4pcs  #9 1pc
	Matel Frame	#J		
	Mounting Plate	#K		
	Finial	#L		
	Bracket	#M		
CM7271EK/CK- 3	Bed Rail	#F		 #5 6pcs  #6 8pcs
	Bed Slats	#G		 #7 8pcs
	Bed Slats Support With Leveler	#H		 #8 1pc
CM7271EK/CK- 4	Finial For Post	#I		
CM7271EK/CK- 5	Headboard Pots (R&L)	#A		
CM7271EK/CK- 6	Footboard Pots (R&L)	#D		

Exploded View

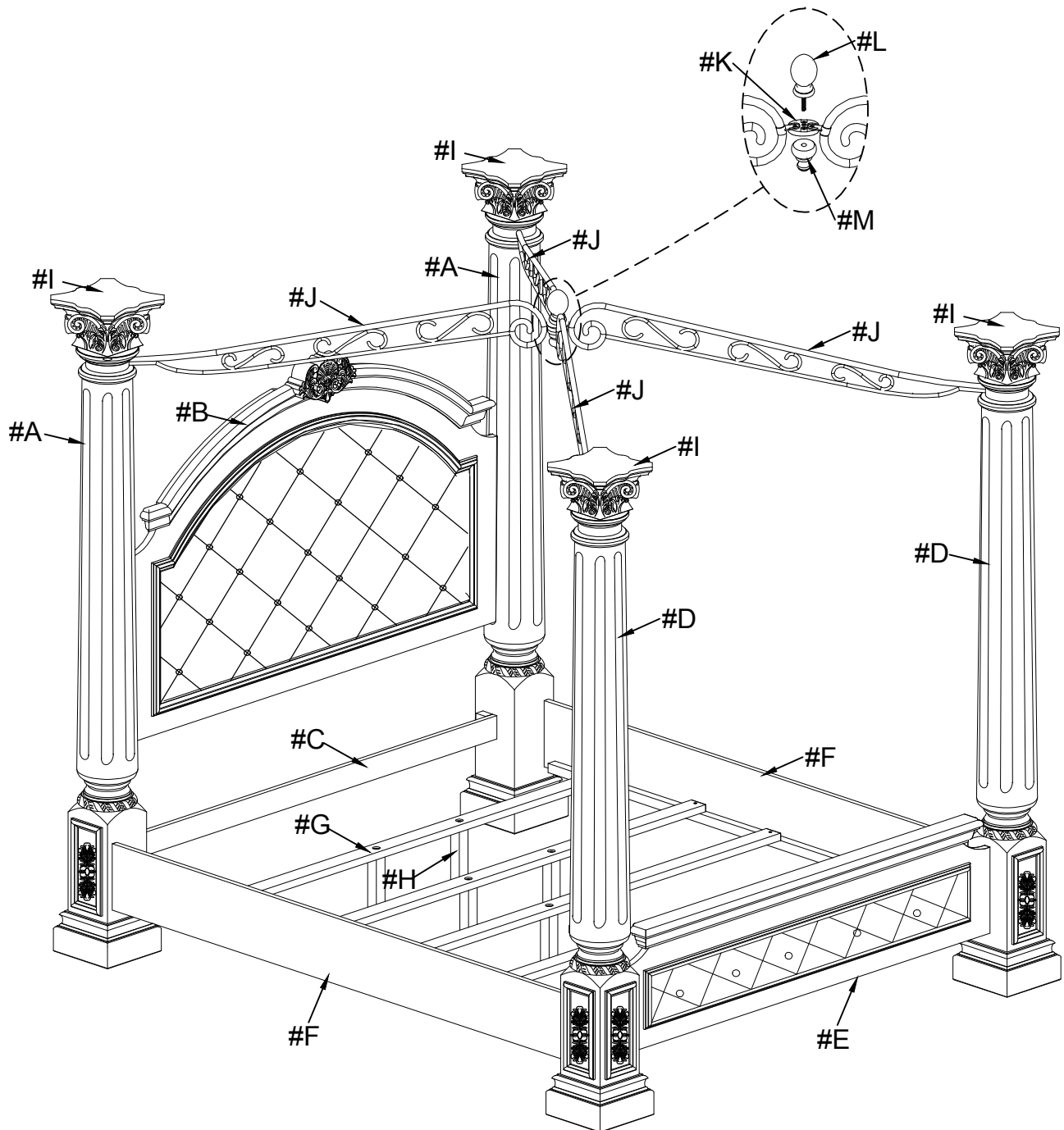

ASSEMBLY INSTRUCTIONS

1

Align HB posts (#A) to the HB panel (#B) and bottom rail (#C), then secure by using bolts (#A) with washers (#3).

- Part (#A) x 2pcs
- Part (#B) x 1pc
- Part (#C) x 1pc
- Hardware (#1) x 10pcs
- Hardware (#3) x 10pcs

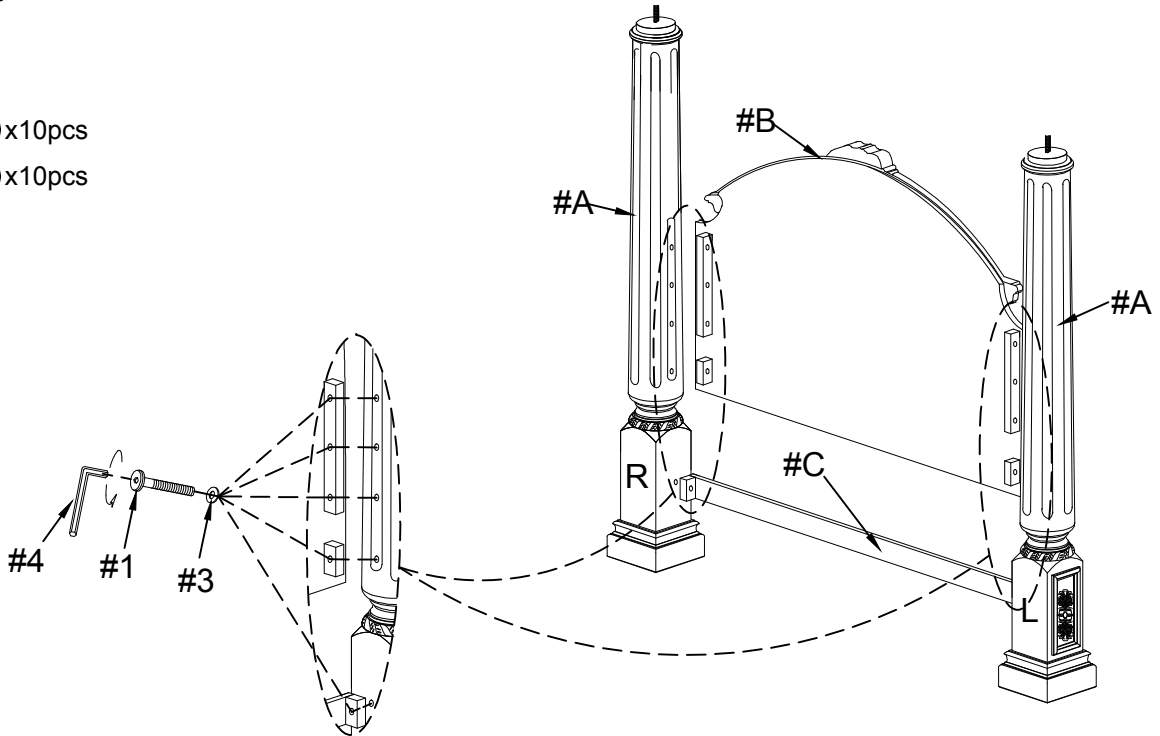

2

- Part (#D) x 2pcs
- Part (#E) x 1pc
- Hardware (#1) x 4pcs
- Hardware (#3) x 4pcs

Align FB posts (#D) to FB panel (#E), then secure by using bolts (#1) with washers (#3).

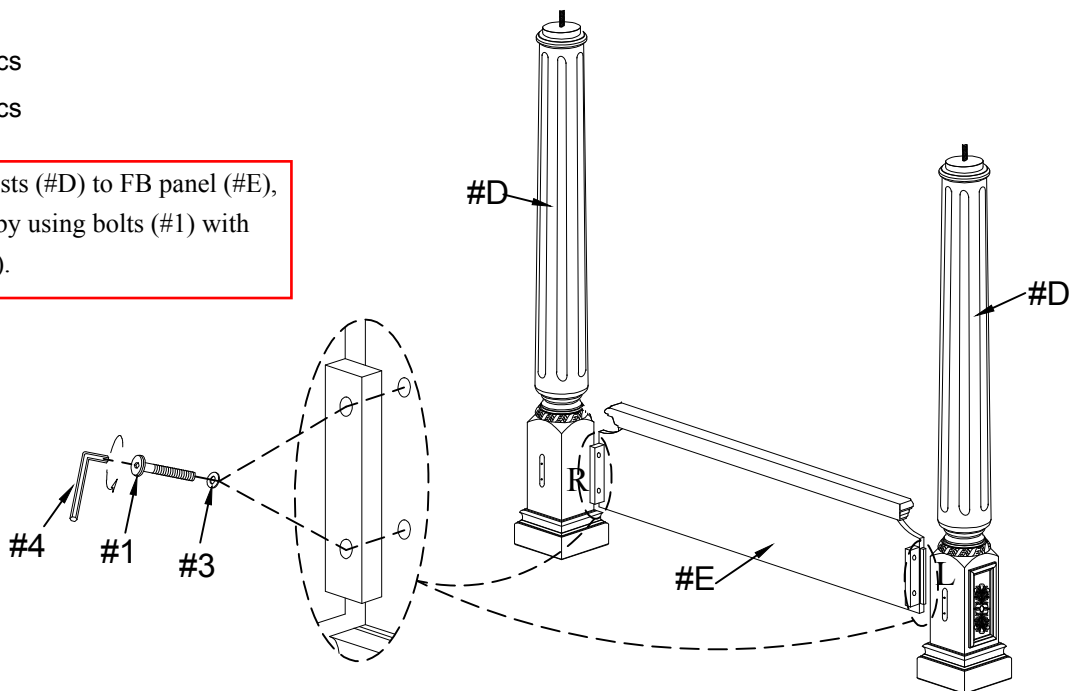

ASSEMBLY INSTRUCTIONS

3

Part #F x2pcs

Hardware #6 x8pcs

Hardware #7 x8pcs

Attach threaded bolts (#6) to the posts, then align the side rails (#F) to the posts. Secure by using hex nuts (#7).

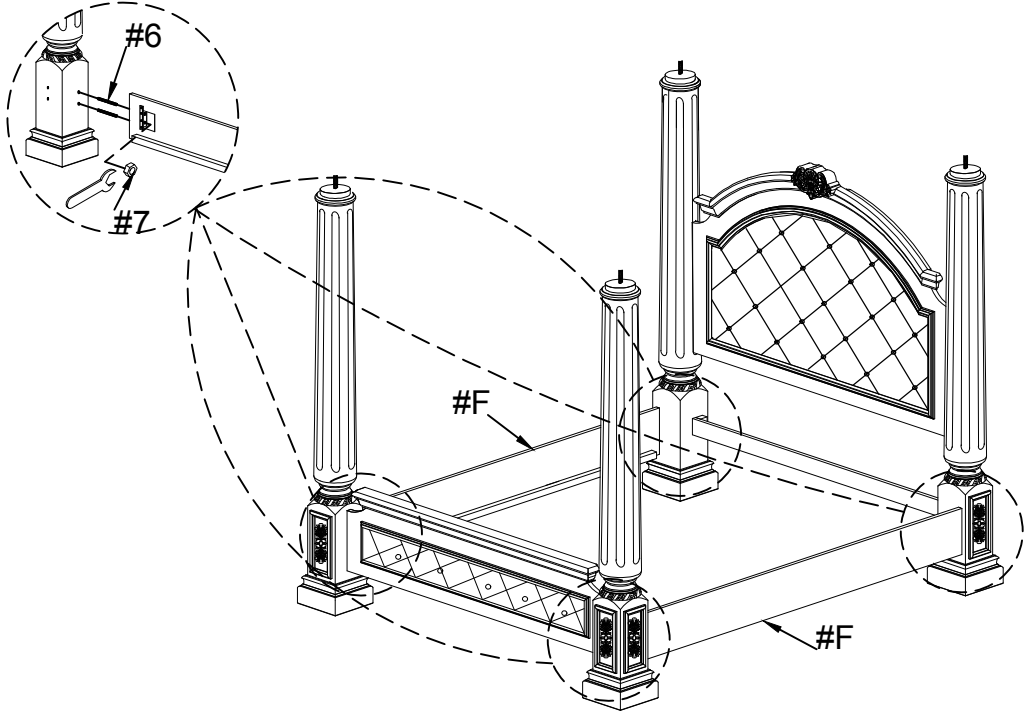

4

Part #G x 1pc

Part #H x 2pcs

Attach support legs (#H) to the slats (#G).

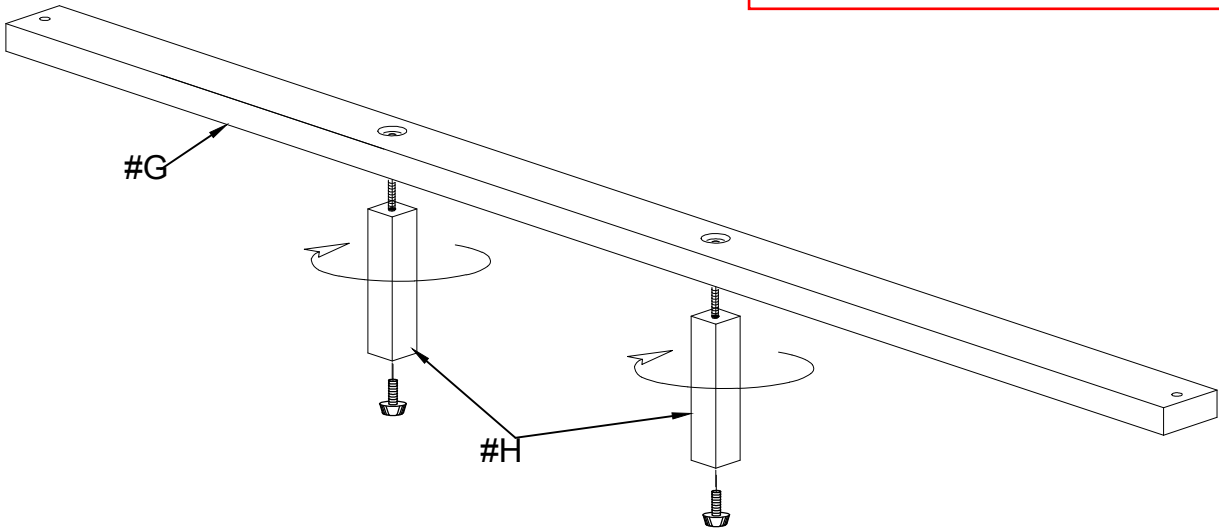

x3

ASSEMBLY INSTRUCTIONS

5

Hardware  x 8pcs

Align slats to the side rails, then secure by using screws (#5).

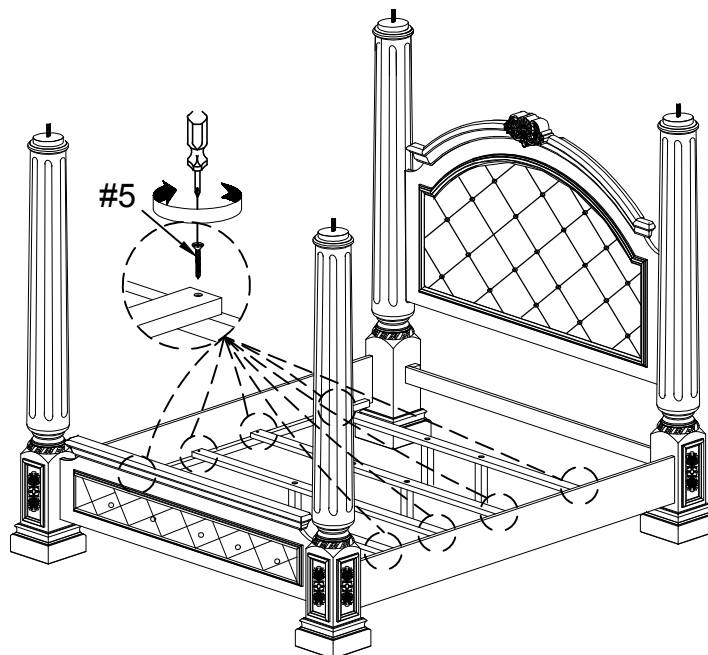

6

Part  x4pcs

Part  x4pcs

Align metal frame to the posts, then secure by using finial (#I).

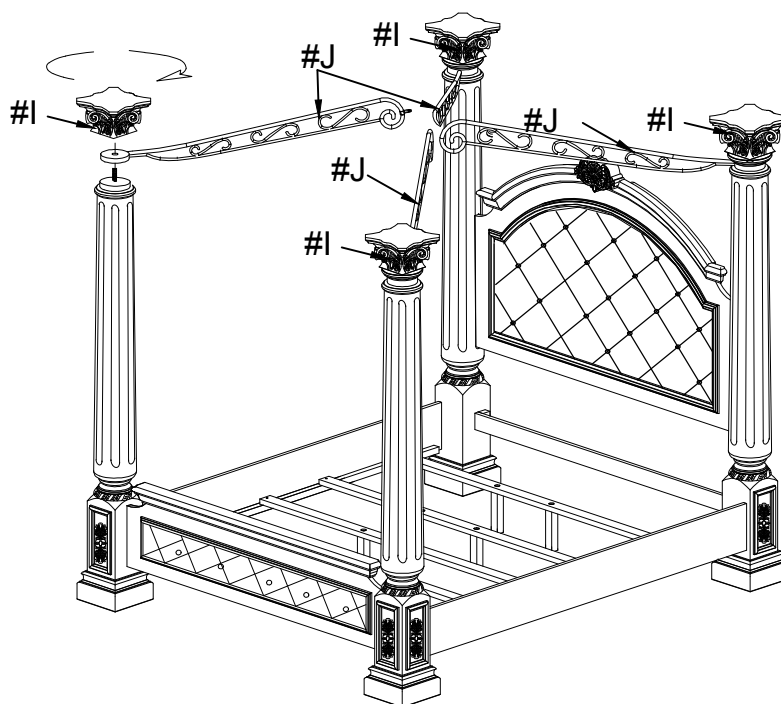

ASSEMBLY INSTRUCTIONS

7

Part #K x1pc
Part #L x1pc
Part #M x1pc
Hardware #2 x4pcs

Align metal frame (#J) to each other, then secure by using finial (#L) to bracket (#M). Secure holes by using bolts (#2).

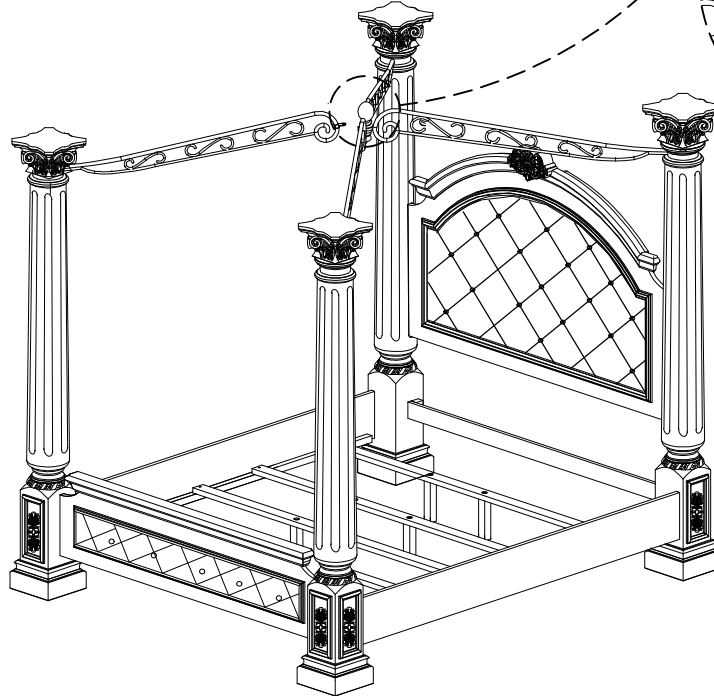

8

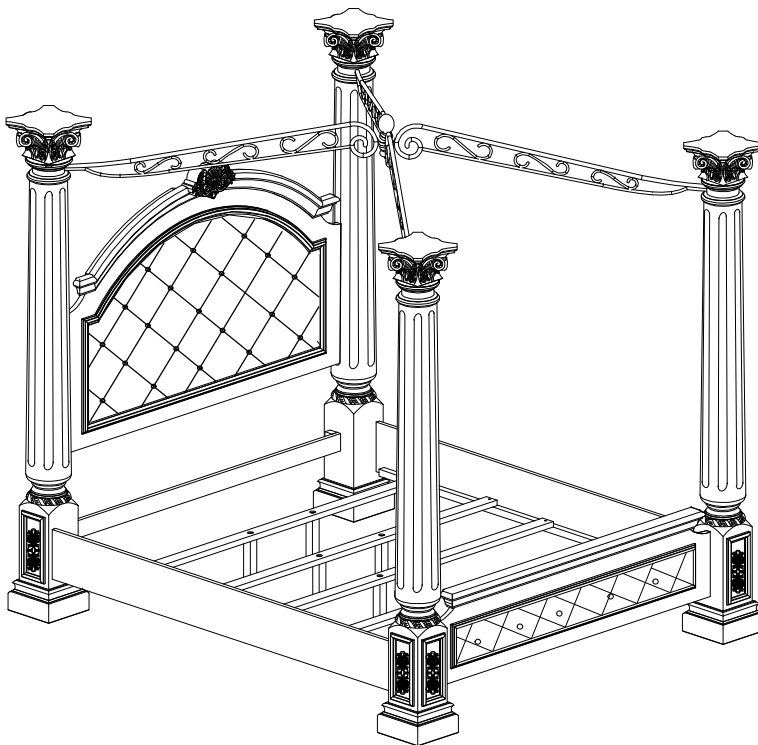

ASSEMBLY COMPLETED



Please ensure the furniture rests on an even and flat surface. If the product wobbles or feels loose, double-check all bolts and/or screws are properly tightened and secured.



Keep this handy!

Please retain this instruction manual and any order-related information for future reference.



Lift, don't drag!

To avoid damage to product please always LIFT the product when transporting or adjusting the placement.