

Assembly Instructions

CM7201F/Q

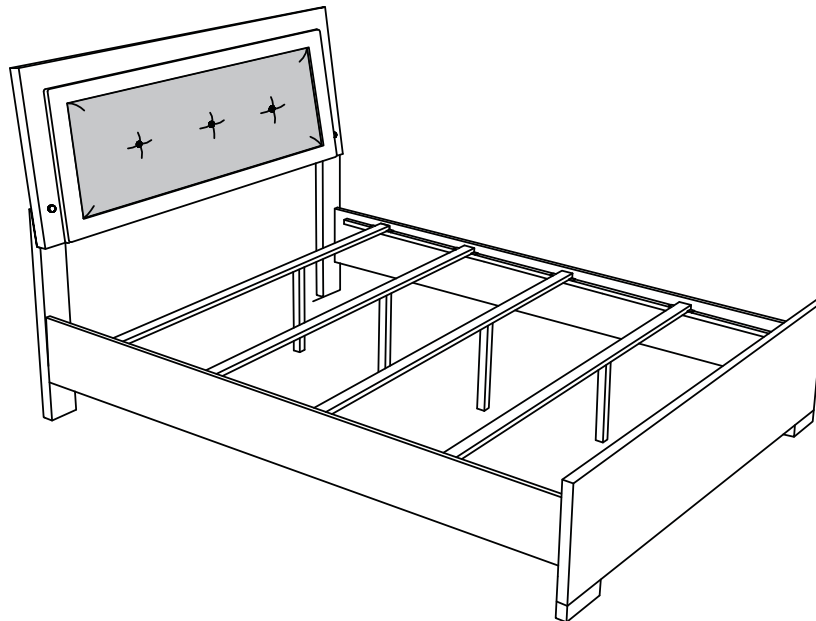

ASSEMBLY RATING

The Assembly Rating is a 5-point system that shows the degree of effort needed in assembling a specific product (with 1 being easy and 5 being difficult). For some products, two persons are recommended.

EASY  DIFFICULT

Tools Required For Assembly:

Allen Wrench

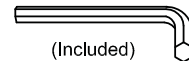

Phillips Screwdriver

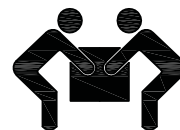
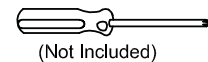

2 PERSONS RECOMMENDED

ASSEMBLY & CARE ADVICE

FOR YOUR FURNITURE TO LAST, CORRECT ASSEMBLY AND PROPER MAINTENANCE ARE NECESSARY. PLEASE FOLLOW THE INFORMATION PROVIDED BELOW TO FULLY ENJOY YOUR FURNITURE.

BASIC ASSEMBLY TECHNIQUES

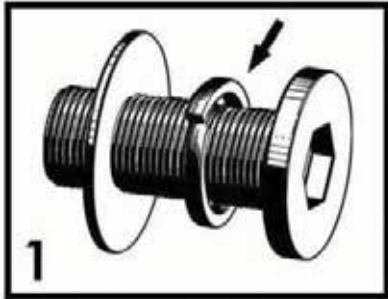

1 When lock or spring washer is used in an assembly, please make sure the lock or spring washer is placed between the larger flat washer and the head of the screw or bolt.



2 Position each part correctly and insert screws or bolts into their respective holes by hand tighten or using the proper hand tool. Only tighten when step is completed or when instructed to do so.

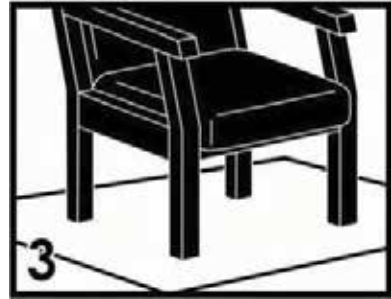

3 Use cardboard or carpet area when assembling furniture to prevent scratches. Make sure the furniture rests on a flat and level surface with each leg evenly touching the floor.

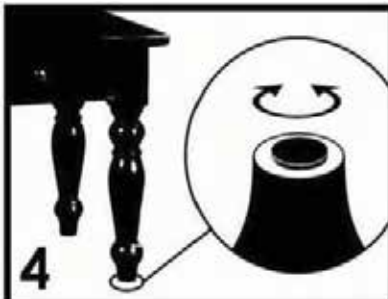

4 Some furniture comes with height adjustment knobs underneath each leg. To lower or to raise each leg, you need to turn clockwise or counterclockwise, respectively.

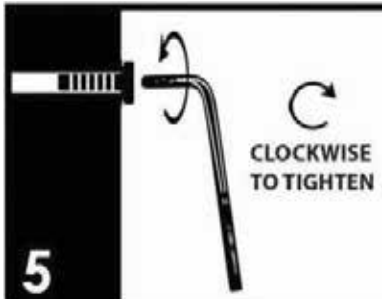

5 Make sure all parts are properly aligned, then use the appropriate hand tool to completely tighten the bolts or screws. Do not use power tools and do not overtighten.

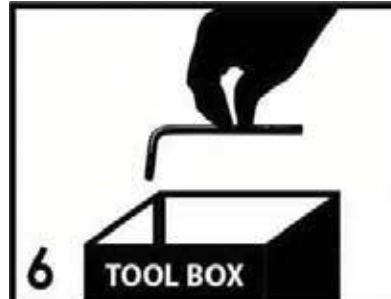

6 Save the instructions and store the Allen wrench or any supplied tool for later maintenance. After two weeks, check and tighten any loose hardware and repeat again every six months thereafter.

IT IS THE USER'S RESPONSIBILITY TO MAINTAIN THE FURNITURE. THE HARDWARE MAY LOOSEN OVER TIME AND MAY CAUSE THE FURNITURE TO BE WOBBLY AND UNABLE TO SUPPORT ITS INTENDED WEIGHT CAPACITY. THIS MAY LEAD TO COLLAPSE AND MAY CAUSE SERIOUS INJURY.

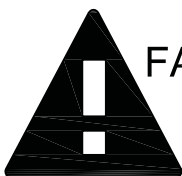

FAILURE TO FOLLOW THE GUIDELINES ABOVE MAY RESULT IN INJURY AND/OR PROPERTY DAMAGE.



Before you begin, please read Page 2 of "Assembly and Care Advice".

And remember, do not tighten until each step is completed or instructed.

Parts List

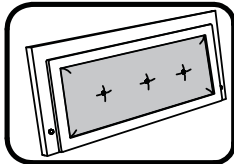

#1 x 1pc
Headboard Panel

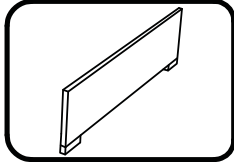

#2 x 1pc
Footboard

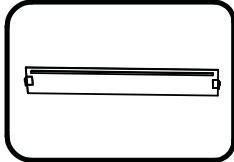

#3 x 2pcs
Side Rail

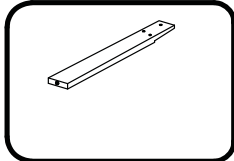

#4 x 2pcs
Headboard Leg (L/R)

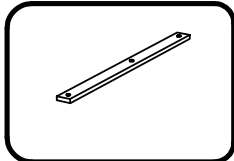

#5 x 4pcs
Bed Slat

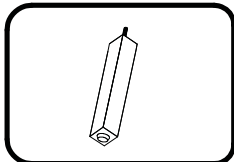

#6 x 4pcs
Bed Slat Support

Hardware List

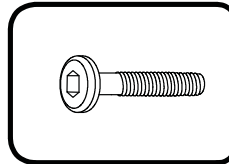

#A x 6pcs
Bolt 1/4" x 1-3/8"

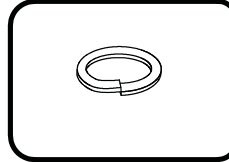

#B x 6pcs
Lock Washer

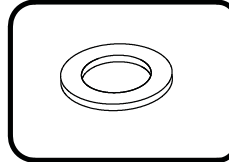

#C x 6pcs
Flat Washer

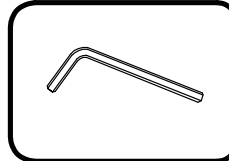

#D x 1pc
Allen Wrench M4

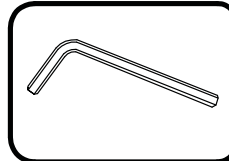

#E x 1pc
Allen Wrench M5

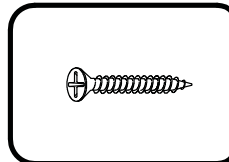

#F x 8pcs
CSK m4 x 32mm

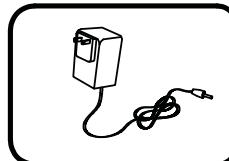

#G x 1pc
12V+12W+1A Adaptor



#1

#A x 6pcs
#B x 6pcs
#C x 6pcs

1. Place the headboard panel (#1) face down onto a protected surface, then align the headboard legs (#4) to the holes along the sides of the headboard.

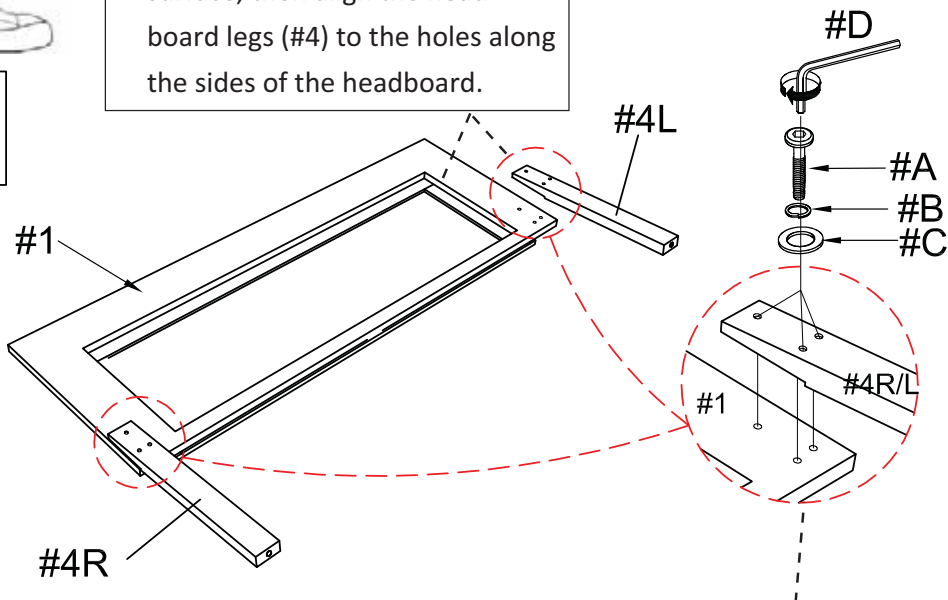

2. Prepare 6 bolt assemblies by inserting a lock washer (#B) onto the bolt (#A) then a flat washer (#C) onto that same bolt (#A). Insert 3 into each leg and secure using the Allen wrench.



#2

Place the hooks at the end of the side rails (#3) onto the bolt heads along the front side of the legs (#4).

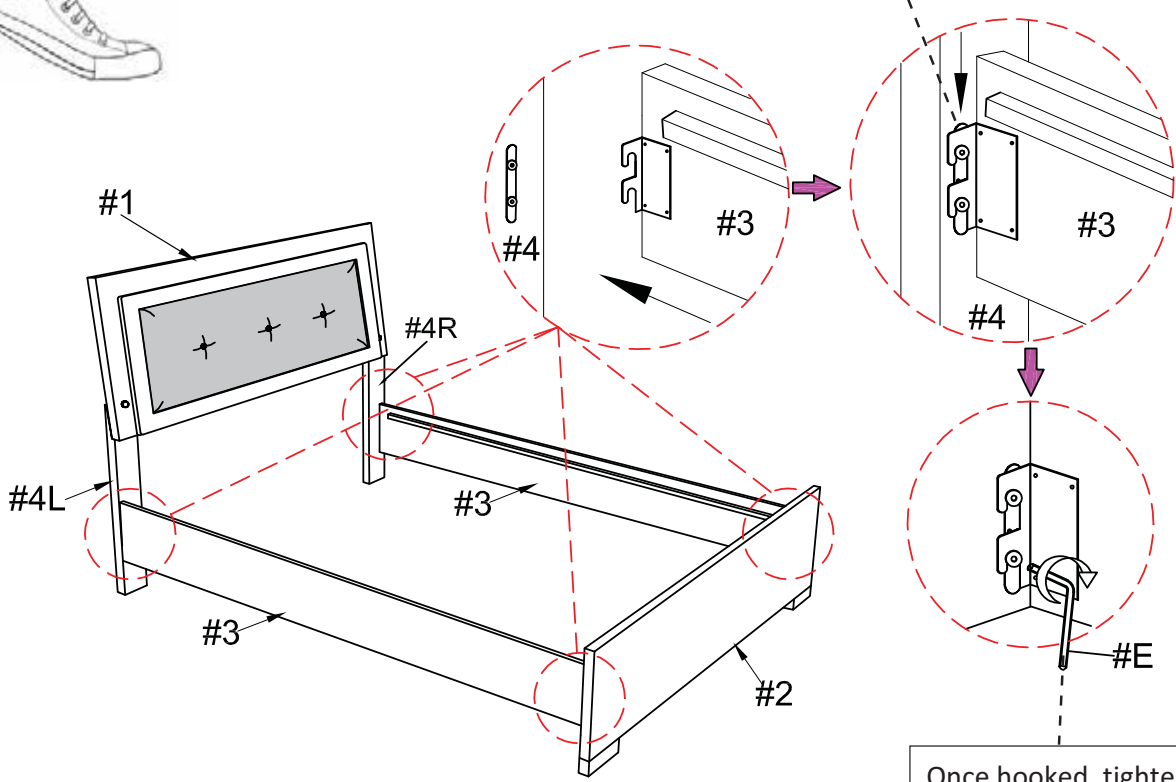

Once hooked, tighten bolts using the Allen wrench (#E).

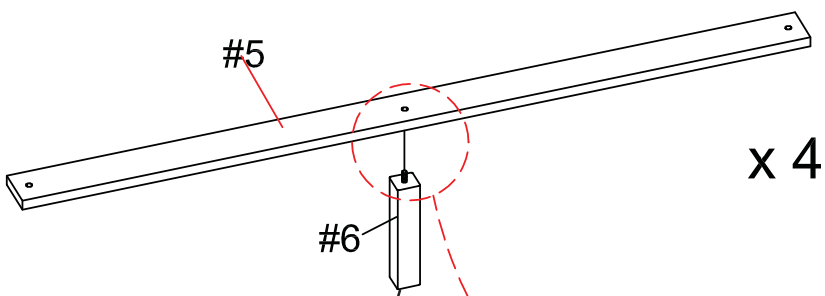

x 4

Insert the threaded ends of the bed slat supports (#6) into the holes along the bed slats (#5). Turn right to tighten.

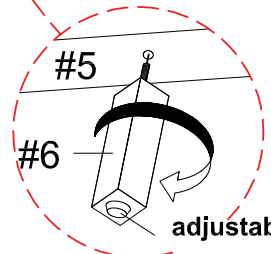

Adjust according to ground level.



#F x 8pcs

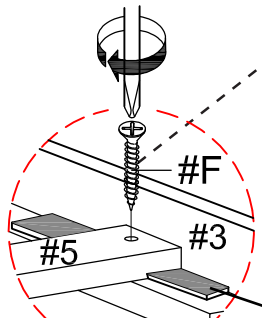
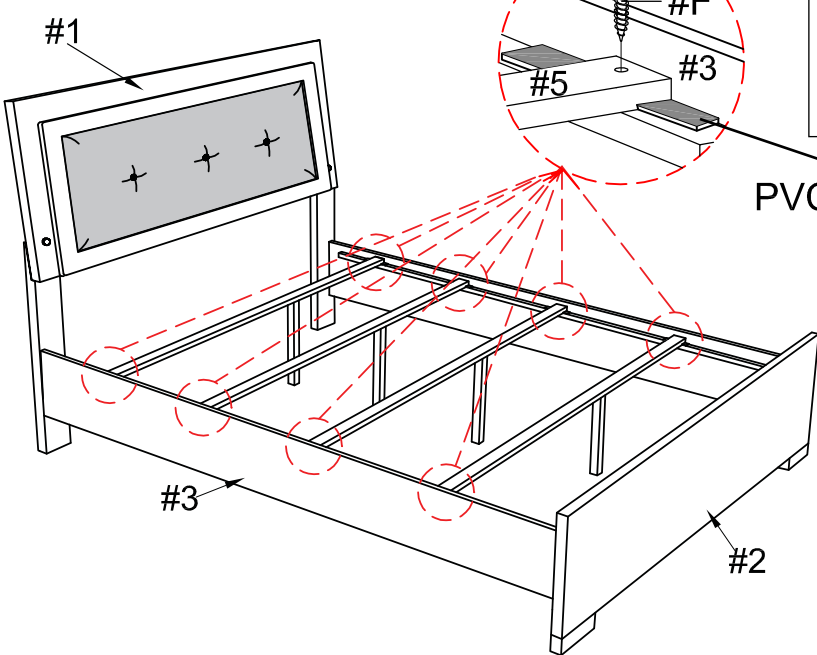

Place each end of the slats (#5) onto a Pvc stopper , then place onto the side rails (#3). Insert a screw (#F) into each end. Secure using a Phillips screwdriver.

PVC STOPPER

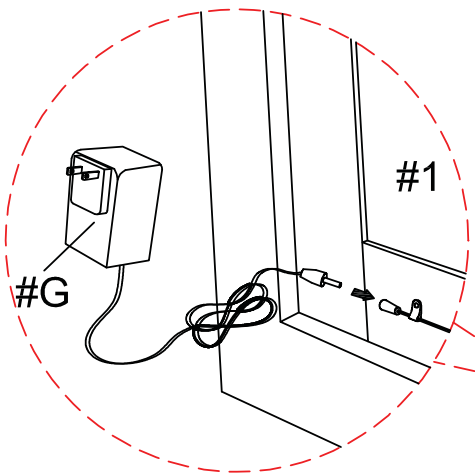

Back View

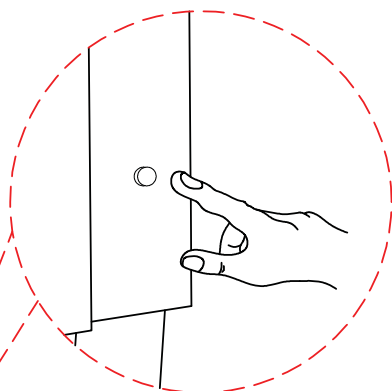

Switch on Button

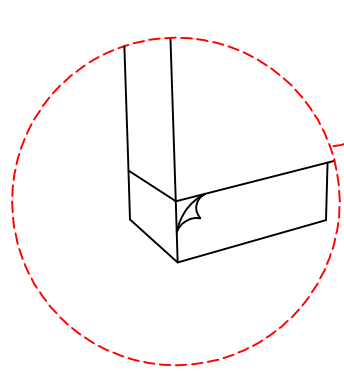
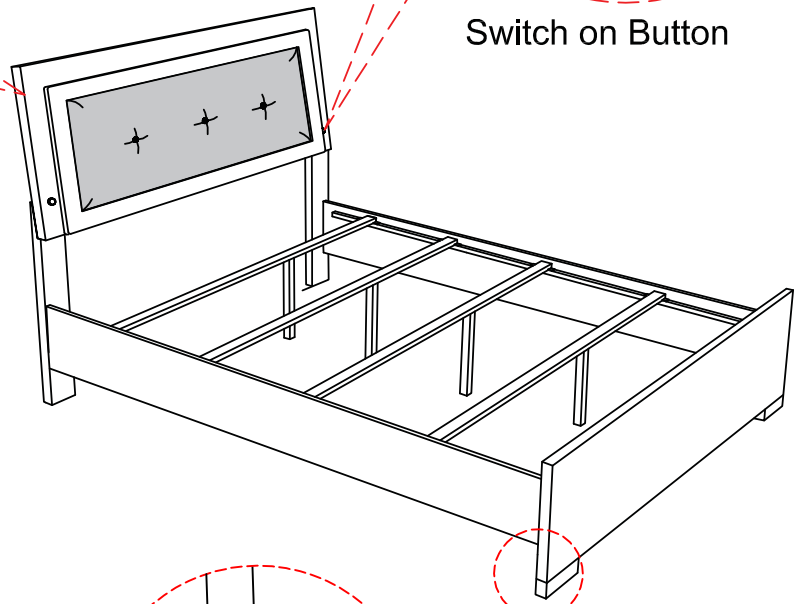

PLEASE REMOVE THE PROTECTIVE FILM BEFORE USE

Assembly Instructions

CM7201EK

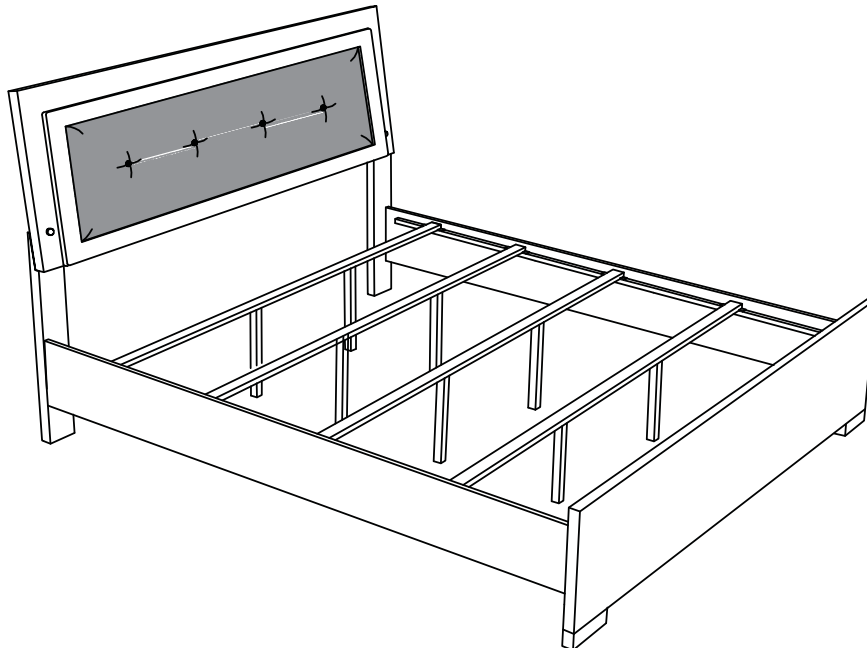

ASSEMBLY RATING

The Assembly Rating is a 5-point system that shows the degree of effort needed in assembling a specific product (with 1 being easy and 5 being difficult). For some products, two persons are recommended.

EASY  DIFFICULT

Tools Required For Assembly:

Allen Wrench

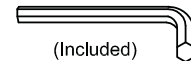

Phillips Screwdriver



2 PERSONS RECOMMENDED

ASSEMBLY & CARE ADVICE

FOR YOUR FURNITURE TO LAST, CORRECT ASSEMBLY AND PROPER MAINTENANCE ARE NECESSARY. PLEASE FOLLOW THE INFORMATION PROVIDED BELOW TO FULLY ENJOY YOUR FURNITURE.

BASIC ASSEMBLY TECHNIQUES

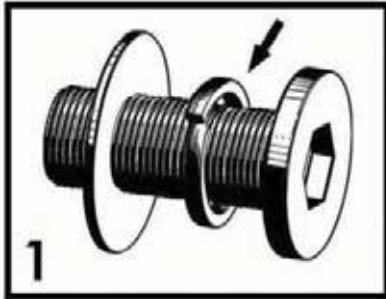

1 When lock or spring washer is used in an assembly, please make sure the lock or spring washer is placed between the larger flat washer and the head of the screw or bolt.

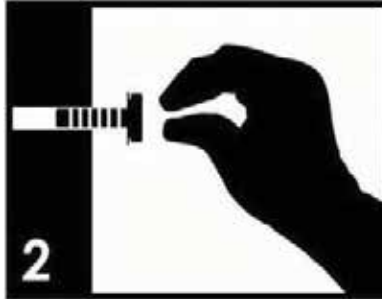

2 Position each part correctly and insert screws or bolts into their respective holes by hand tighten or using the proper hand tool. Only tighten when step is completed or when instructed to do so.



3 Use cardboard or carpet area when assembling furniture to prevent scratches. Make sure the furniture rests on a flat and level surface with each leg evenly touching the floor.

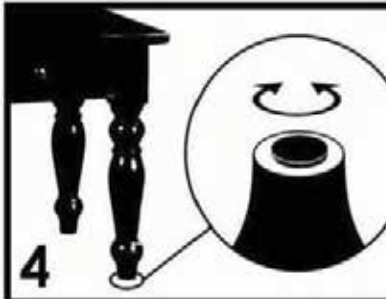

4 Some furniture comes with height adjustment knobs underneath each leg. To lower or to raise each leg, you need to turn clockwise or counterclockwise, respectively.

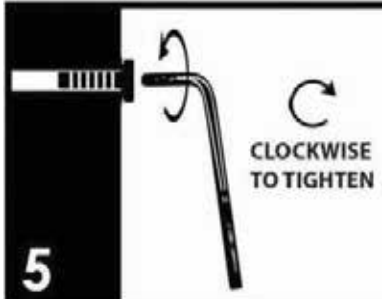

5 Make sure all parts are properly aligned, then use the appropriate hand tool to completely tighten the bolts or screws. Do not use power tools and do not overtighten.

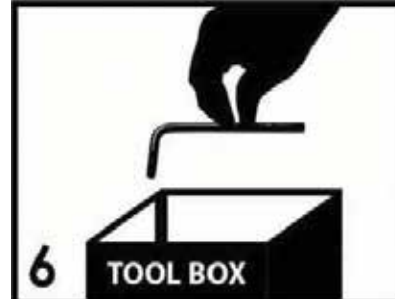

6 Save the instructions and store the Allen wrench or any supplied tool for later maintenance. After two weeks, check and tighten any loose hardware and repeat again every six months thereafter.

IT IS THE USER'S RESPONSIBILITY TO MAINTAIN THE FURNITURE. THE HARDWARE MAY LOOSEN OVER TIME AND MAY CAUSE THE FURNITURE TO BE WOBBLY AND UNABLE TO SUPPORT ITS INTENDED WEIGHT CAPACITY. THIS MAY LEAD TO COLLAPSE AND MAY CAUSE SERIOUS INJURY.

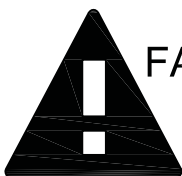

FAILURE TO FOLLOW THE GUIDELINES ABOVE MAY RESULT IN INJURY AND/OR PROPERTY DAMAGE.



Before you begin, please read Page 2 of "Assembly and Care Advice".

And remember, do not tighten until each step is completed or instructed.

Parts List

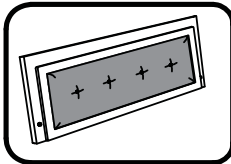

#1 x 1pc
Headboard Panel

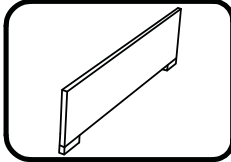

#2 x 1pc
Footboard

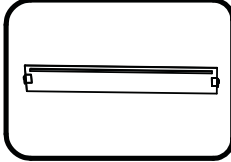

#3 x 2pcs
Side Rail

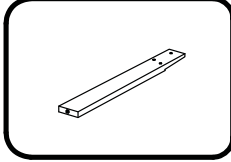

#4 x 2pcs
Headboard Leg (L/R)

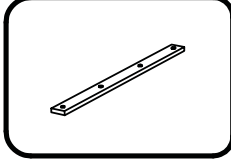

#5 x 4pcs
Bed Slat

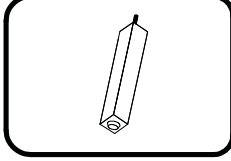

#6 x 8pcs
Bed Slat Support

Hardware List

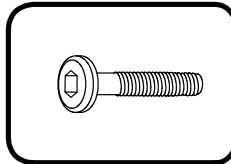

#A x 6pcs
Bolt 1/4" x 1-3/8"

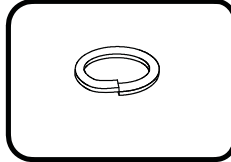

#B x 6pcs
Lock Washer

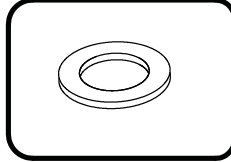

#C x 6pcs
Flat Washer

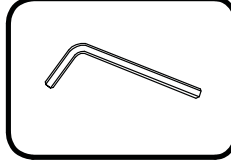

#D x 1pc
Allen Wrench M4

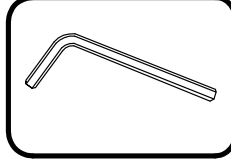

#E x 1pc
Allen Wrench M5

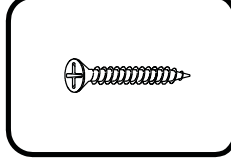

#F x 8pcs
CSK m4 x 32mm

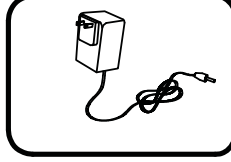

#G x 1pc
12V+12W+1A Adaptor



#1

#A x 6pcs
#B x 6pcs
#C x 6pcs

1. Place the headboard panel (#1) face down onto a protected surface, then align the headboard legs (#4) to the holes along the sides of the headboard.

2. Prepare 6 bolt assemblies by inserting a lock washer (#B) onto the bolt (#A) then a flat washer (#C) onto that same bolt (#A). Insert 3 into each leg and secure using the Allen wrench.

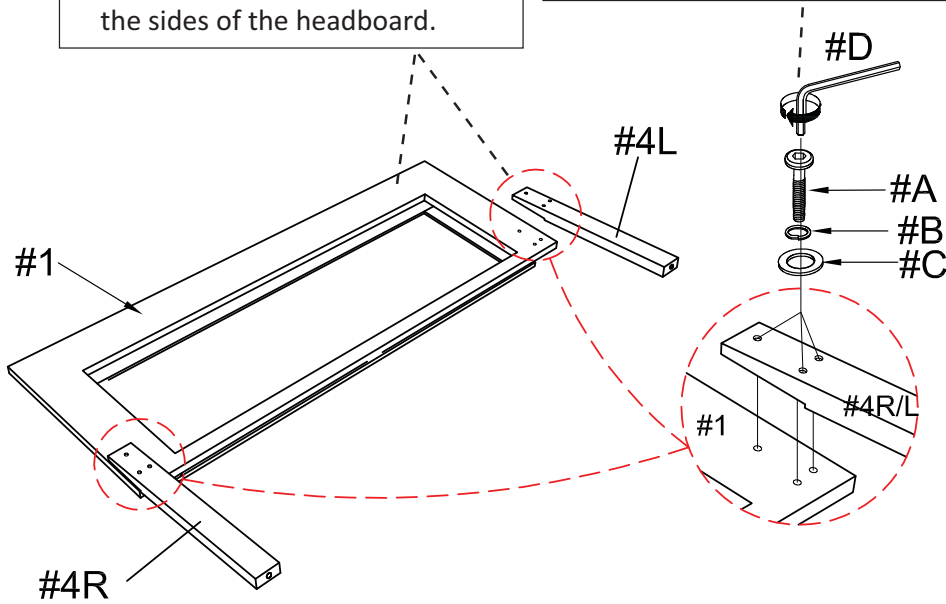

#2

Place the hooks at the end of the side rails (#3) onto the bolt heads along the front side of the legs (#4).

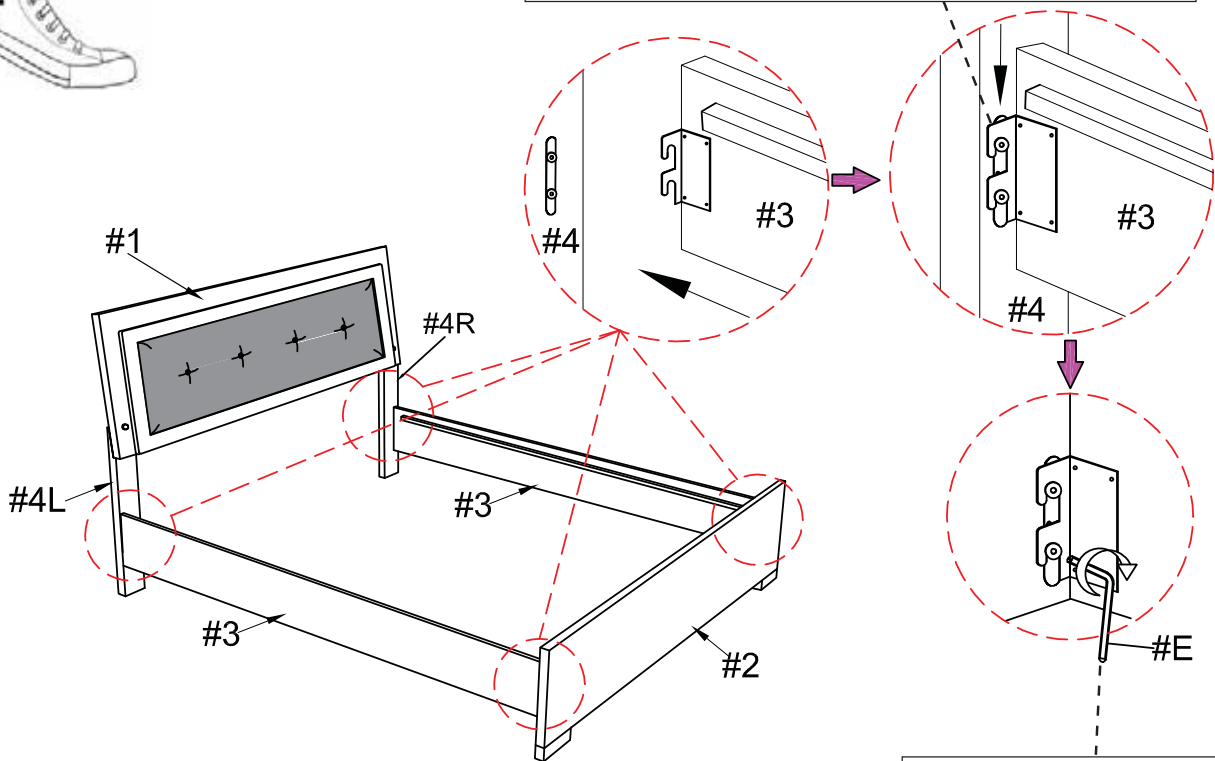

Once hooked, tighten bolts using the Allen wrench (#E).

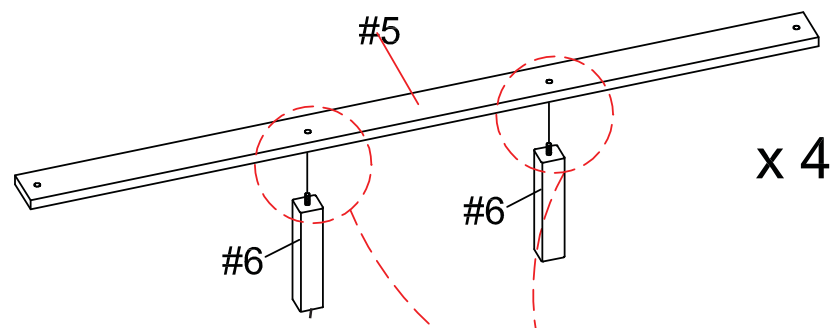

Insert the threaded ends of the bed slat supports (#6) into the holes along the bed slats (#5). Turn right to tighten.

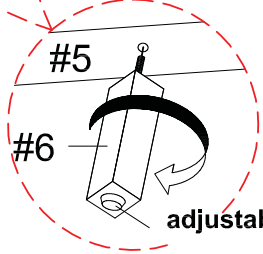

Adjust according to ground level.

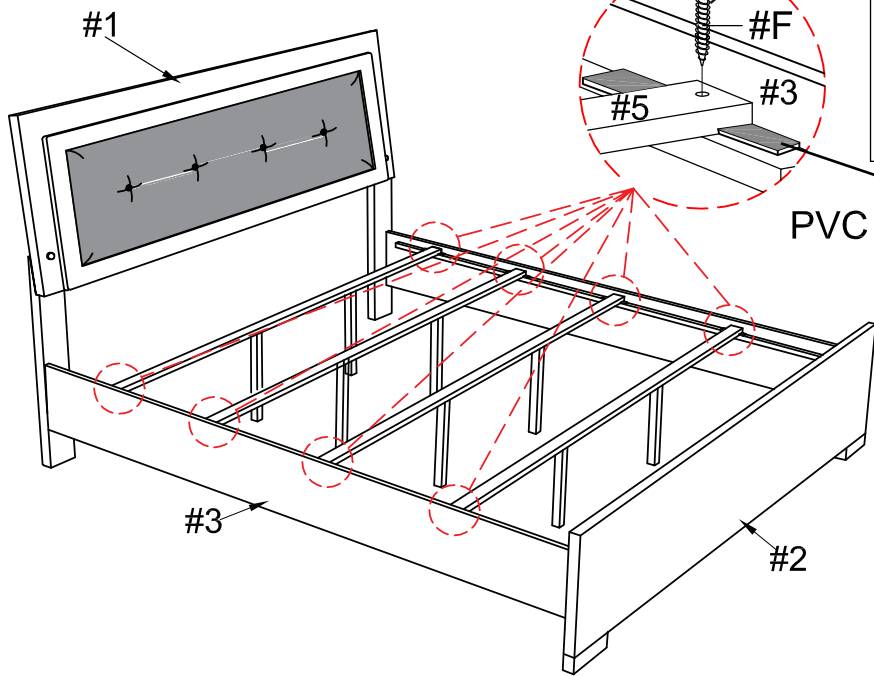

Place each end of the slats (#5) onto a Pvc stopper , then place onto the side rails (#3). Insert a screw (#F) into each end. Secure using a Phillips screwdriver.

PVC STOPPER

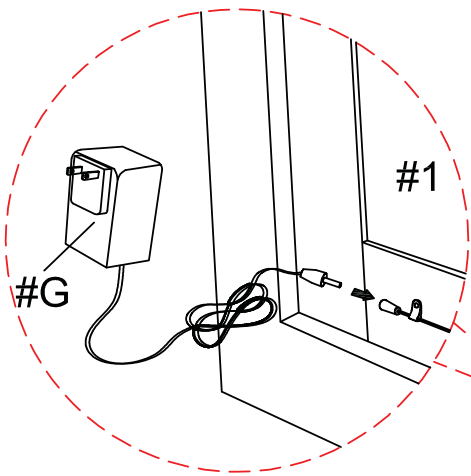

Back View

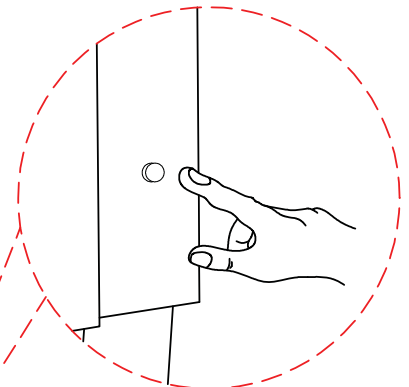

Switch on Button

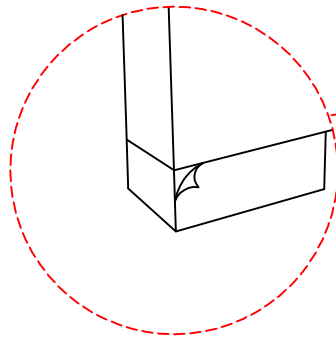
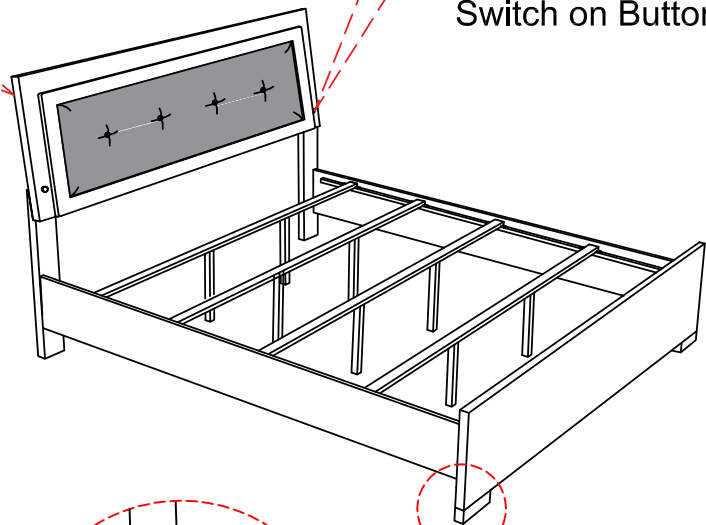

PLEASE REMOVE THE PROTECTIVE FILM BEFORE USE