

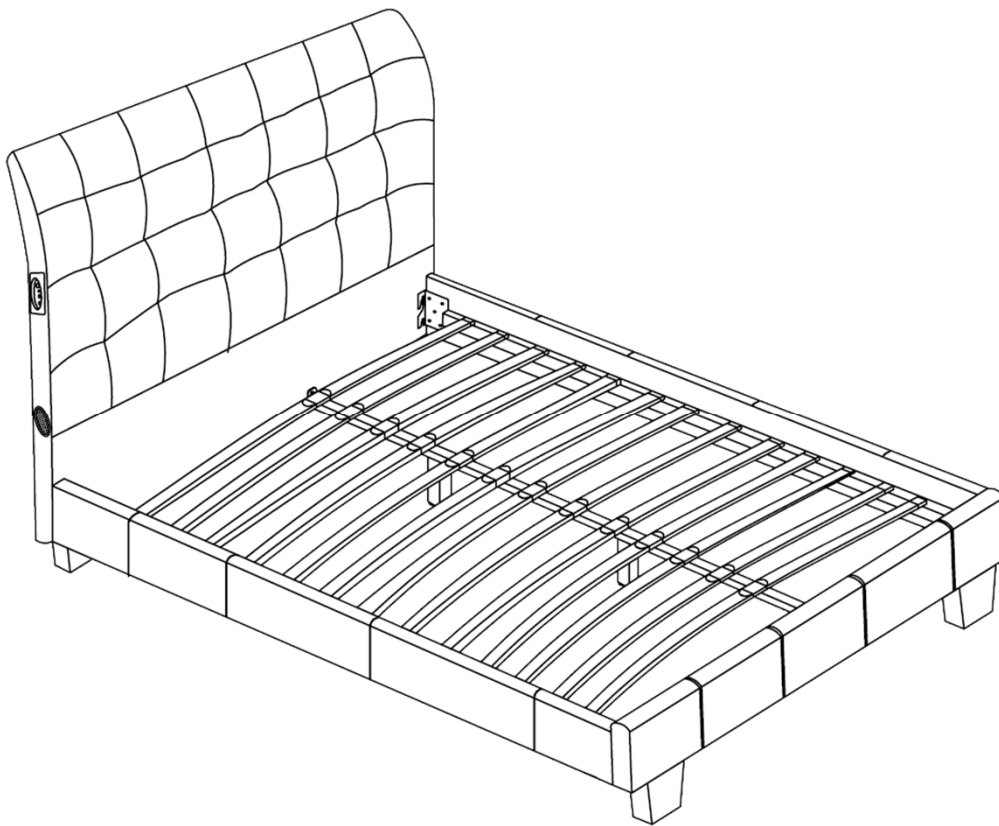

**Furniture of America™**

# Assembly Instructions

## CM7057-F/Q



### ASSEMBLY RATING

The Assembly Rating is a 5-point system that shows the degree of effort needed in assembling a specific product (with 1 being easy and 5 being difficult). For some products, two persons are recommended.

EASY  DIFFICULT

### Tools Required for Assembly:

Allen Wrench



(Included)



2 PERSONS RECOMMENDED

# ASSEMBLY & CARE ADVICE

FOR YOUR FURNITURE TO LAST, CORRECT ASSEMBLY AND PROPER MAINTENANCE ARE NECESSARY. PLEASE FOLLOW THE INFORMATION PROVIDED BELOW TO FULLY ENJOY YOUR FURNITURE.

## BASIC ASSEMBLY TECHNIQUES

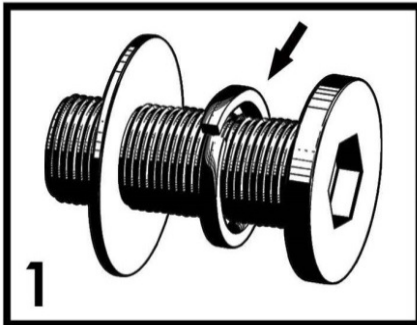

1 When lock or spring washer is used in an assembly, please make sure the lock or spring washer is placed between the larger flat washer and the head of the screw or bolt.



2 Position each part correctly and insert screws or bolts into their respective holes by hand tighten or using the proper hand tool. Only tighten when step is completed or when instructed to do so.

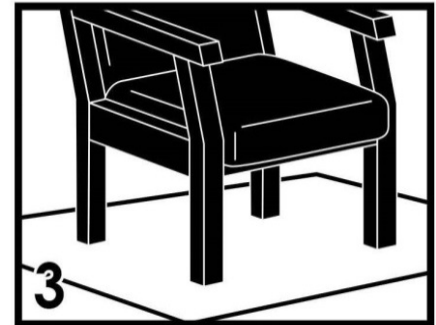

3 Use cardboard or carpet area when assembling furniture to prevent scratches. Make sure the furniture rests on a flat and level surface with each leg evenly touching the floor.

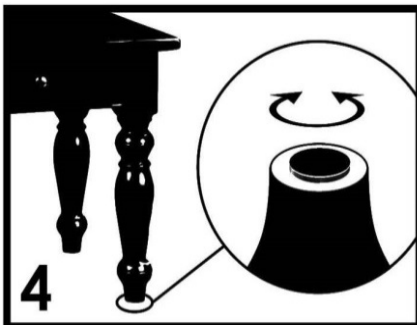

4 Some furniture comes with height adjustment knobs underneath each leg. To lower or to raise each leg, you need to turn clockwise or counterclockwise, respectively.

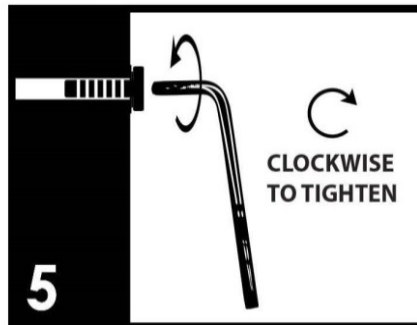

5 Make sure all parts are properly aligned, then use the appropriate hand tool to completely tighten the bolts or screws. Do not use power tools and do not overtighten.

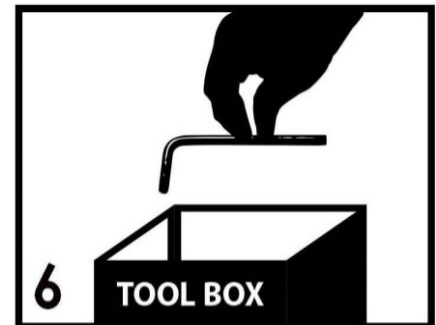

6 Save the instructions and store the Allen wrench or any supplied tool for later maintenance. After two weeks, check and tighten any loose hardware and repeat again every six months thereafter.

IT IS THE USER'S RESPONSIBILITY TO MAINTAIN THE FURNITURE. THE HARDWARE MAY LOOSEN OVER TIME AND MAY CAUSE THE FURNITURE TO BE WOBBLY AND UNABLE TO SUPPORT ITS INTENDED WEIGHT CAPACITY. THIS MAY LEAD TO COLLAPSE AND MAY CAUSE SERIOUS INJURY.



FAILURE TO FOLLOW THE GUIDELINES ABOVE MAY RESULT IN INJURY AND/OR PROPERTY DAMAGE.







Before you begin, please read Page 2 of "Assembly and Care Advice".







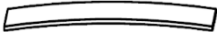
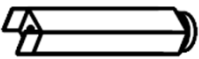

And remember, do not tighten until each step is completed or instructed.

MD

### Parts List

-  #1 x 1 pc  
Headboard
-  #2 x 2 pcs  
Side Rail
-  #3 x 1 pc  
Footboard
-  #4 x 1 pc  
Central Support Rail
-  #5 x 4 pcs  
Foot
-  #6 x 26 pcs  
Slat
-  #7 x 2 pcs  
Slat Support Leg

### Hardware List

-  #A x 8 pcs  
Bolt M8x1"
-  #B x 6 pcs  
Bolt M8x1-1/2"
-  #C x 8 pcs  
Bolt M8x3"
-  #D x 22 pcs  
Flat Washer
-  #E x 22 pcs  
Lock Washer
-  #F x 13 pcs  
Center Connector
-  #G x 26 pcs  
End Cap
-  #H x 1 pc  
Allen Wrench



Due to the size and/or weight of this product, it is highly recommended that the assembly should be done near the area of its intended location. Make sure you have enough space to move around during the assembly. ALWAYS have at least two people to help with transporting and assembling the product to avoid any potential injury and/or damage.



- I. Align the feet (#5) onto the pre-drilled holes on the bottom corners of the headboard (#1).
- II. Prepare 4 bolt assemblies by inserting FIRST the lock washer (#E) onto the bolt (#C) and then the flat washer (#D) onto the SAME bolt (#C), in that order.
- III. Insert the bolt assemblies through the holes of the feet (#5) and secure those bolts using the Allen wrench (#H) to lock them in with the headboard (#1).
- IV. Repeat the process above to assemble the feet (#5) onto the footboard (#3).

#C x 8 pcs  
#D x 8 pcs  
#E x 8 pcs

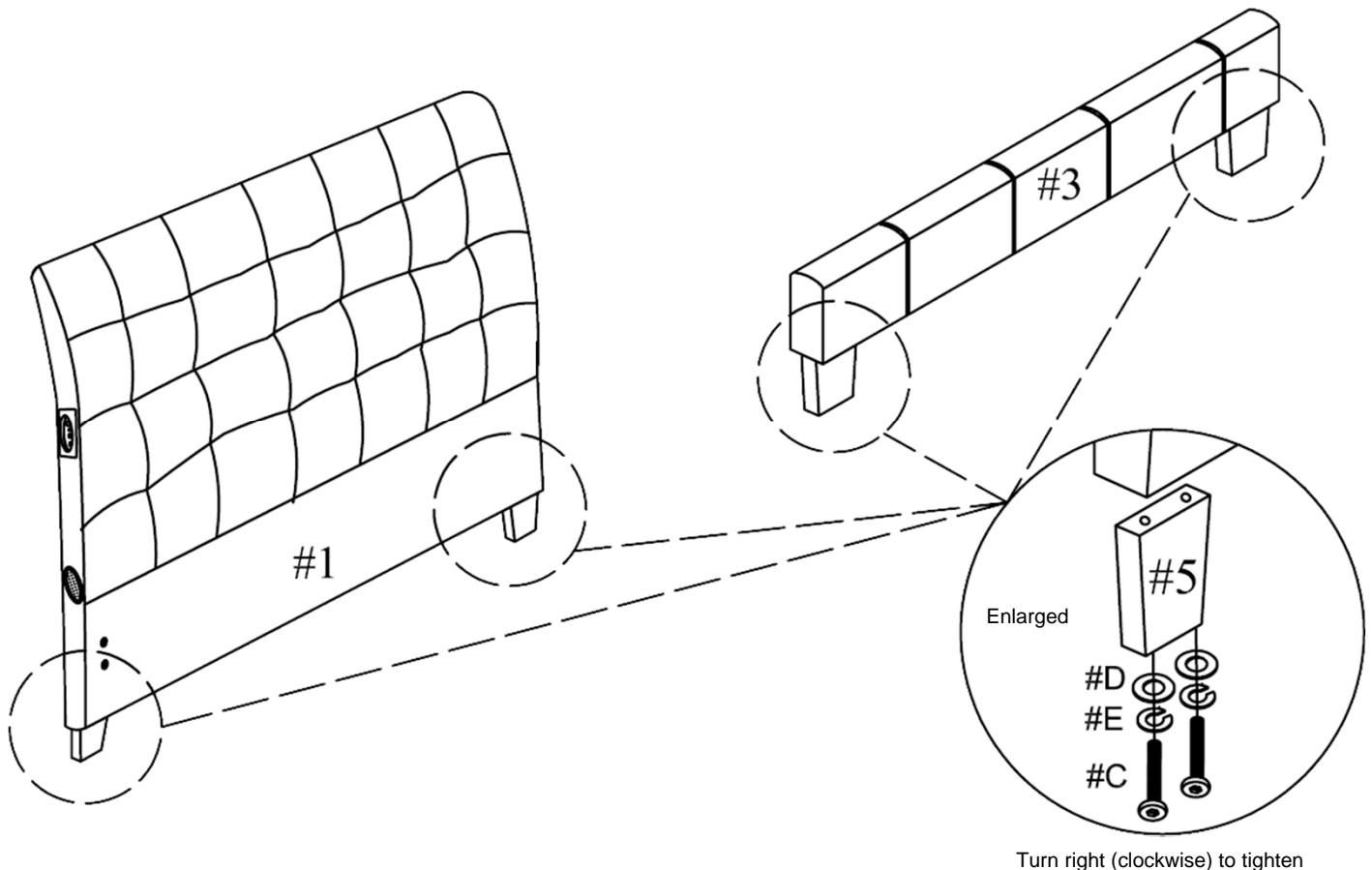



#A x 8 pcs  
#D x 8 pcs  
#E x 8 pcs

- I. Prepare 4 bolt assemblies by inserting FIRST the lock washer (#E) onto the bolt (#A) and then the flat washer (#D) onto the SAME bolt (#A), in that order.
- II. Insert two bolt assemblies through the right and left side of the pre-drilled holes of the headboard (#1) using the Allen wrench (#H) but expose about 1/2" of the bolts' threads.
- III. Mount the brackets of the side rails (#2) onto the bolts (#A) on each side of the headboard (#1). Make sure all the washers are in the FRONT of the brackets. Use the Allen wrench (#H) to tighten the bolts with the two parts together.
- IV. Repeat the process I through III above to assemble the other ends of the side rails (#2) onto the footboard (#3).

Turn right (clockwise) to tighten

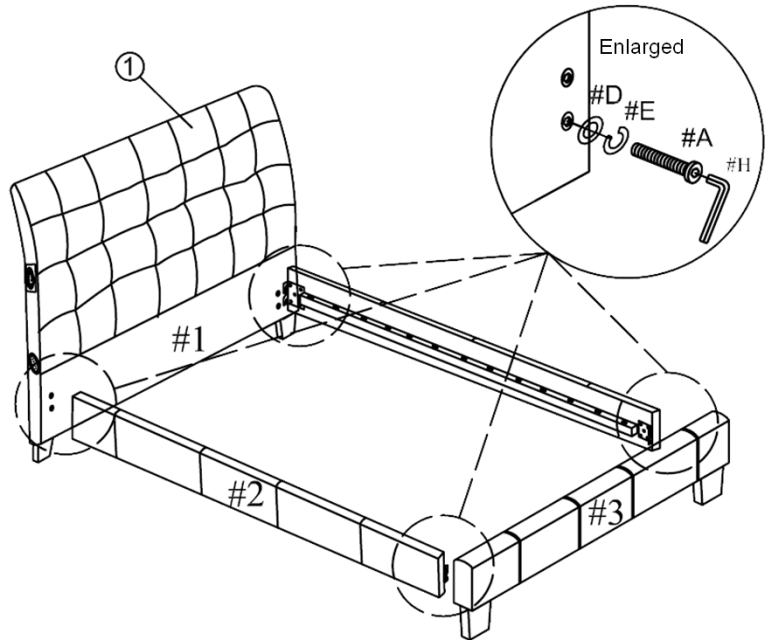

- I. Align the two slat support legs (#7) with the pre-drilled holes of the central support rail (#4).
- II. Prepare 2 bolt assemblies by inserting FIRST the lock washer (#E) onto the bolt (#B) and then the flat washer (#D) onto the SAME bolt (#B), in that order.
- III. Insert the two bolt assemblies through the pre-drilled holes of the central support rail (#4) using the Allen wrench (#H) to lock them in with the slat support legs (#7).

#B x 2 pcs  
#D x 2 pcs  
#E x 2 pcs

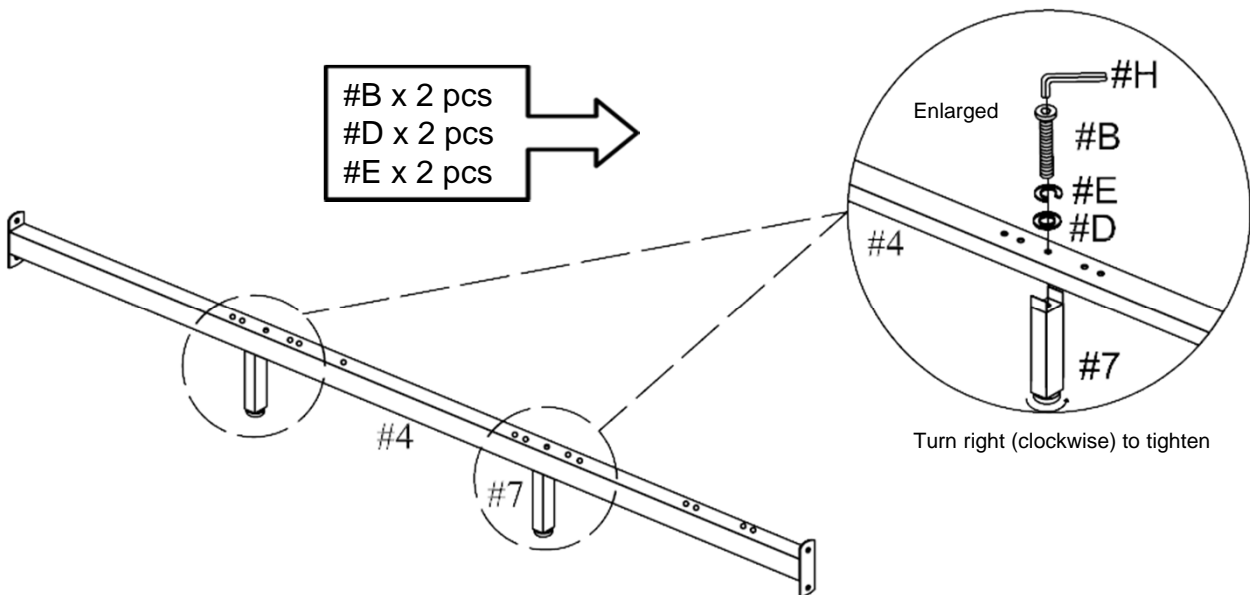

Turn right (clockwise) to tighten



#B x 4 pcs  
 #D x 4 pcs  
 #E x 4 pcs

- I. Align the central support rail (#4) with the pre-drilled holes on the center of the headboard (#1) and the footboard (#3).
- II. Prepare 4 bolt assemblies by inserting FIRST the lock washer (#E) onto the bolt (#B) and then the flat washer (#D) onto the SAME bolt (#B), in that order.
- III. Insert the 4 bolt assemblies through the brackets of the central support rail (#4) using the Allen wrench (#H) to lock them in with the headboard (#1) and the footboard (#3).

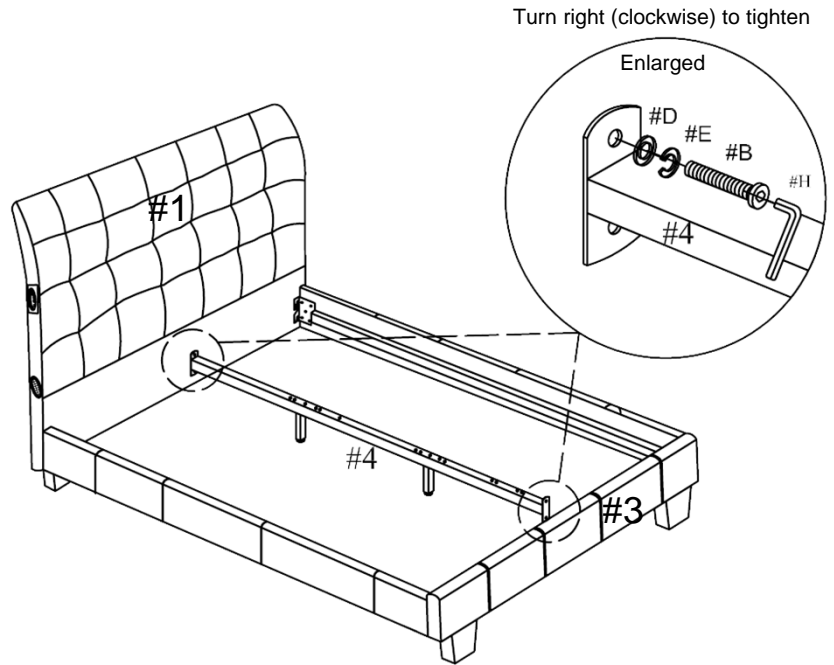

Note: The correct position of the bed slats should be arcing UPWARD when placing on the rails.

#F x 13 pcs  
 #G x 26 pcs

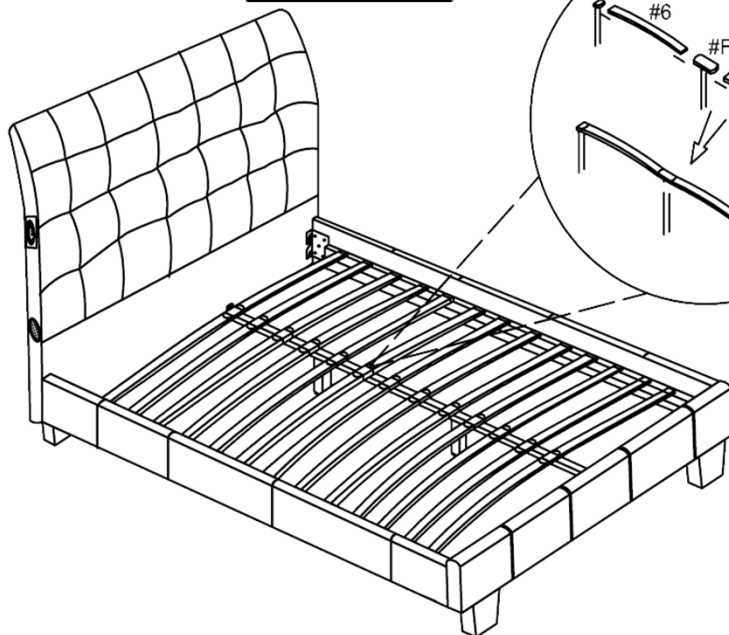

- I. Prepare a complete bed slat by inserting one center plastic connector (#F) onto the ends of two bed slats (#6). Then connect two end caps (#G) onto the other ends of the bed slats (#6).
- II. Align the end caps (#G) with the pre-drilled holes on each side of the side rails (#2) and snap both ends to lock in place. Then snap the center plastic connector (F) onto the central support rail (#4).
- III. Repeat the above process for the remaining bed slats.

**ASSEMBLY IS COMPLETED**