

ASSEMBLY INSTRUCTIONS

MODEL #

CM7056F/Q-VN

Questions?

GIVE US A CALL: 1-888-980-5122
MON-FRI 8:30AM - 5:30PM (PT)

TOOLS REQUIRED



Allen Wrench

(Included)



Phillips
Screwdriver

(Not Included)



**3 - People
Recommended**

ASSEMBLY RATING



EASY → DIFFICULT

The Assembly Rating is a 5-point system showing the level of effort needed to assemble a specific product.

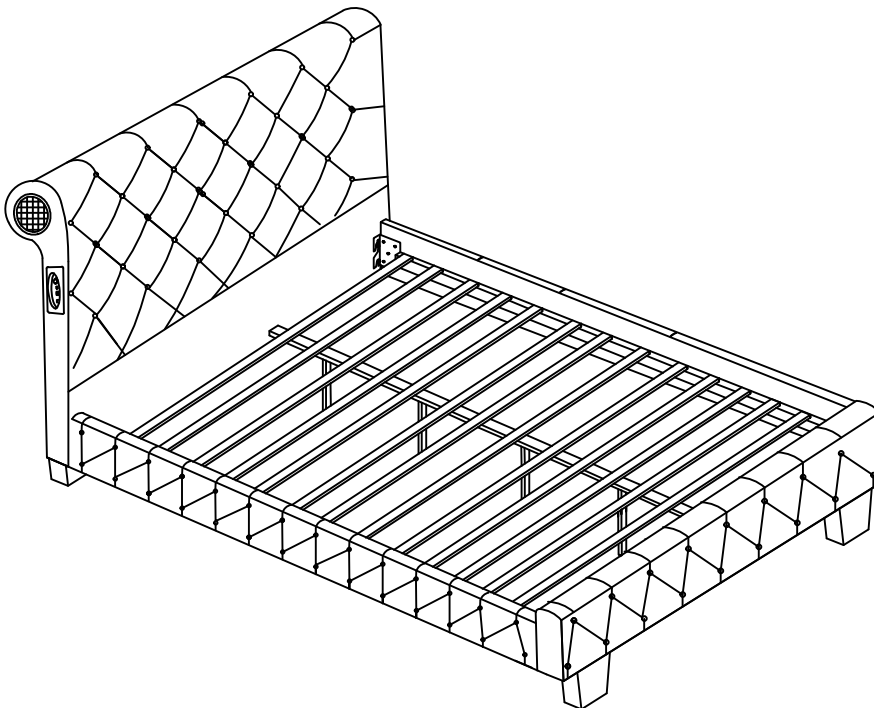



FOA Intro

Thank you for your purchase!

We hope you enjoy this new addition to your home for many years to come.

Our commitment to providing quality products does not simply end when you purchase our product. We fully stand behind our products from start to finish. Our customer service department is available Monday – Friday 8:30 AM – 5:30 PM Pacific Time and can help with assembly questions as well as, if necessary, replacing damaged or missing parts. To help expedite our service, please have these assembly instructions readily available, along with your order receipt.

 **Consumer Hotline**
Toll-Free 1-888-980-5122

 **WEBSITE**
www.foagroup.com

 **Monday to Friday**
8:30AM- 5:30PM (PT)

 **E-MAIL**
cs.ec@foagroup.com



CHECK BEFORE STARTING

Are you missing anything?
Double-check all parts, hardware and accessories listed are all accounted for.

Check out our Quick Tips!
We recommend reviewing the pre-assembly handouts. Even experts need a refresher now and then!

Should we send any replacements?
Are there any irregularities or flaws in the parts? We can send replacements!

Prep Time!
Please review the assembly instructions and all diagrams prior to assembling.

PRE ASSEMBLY INTRODUCTION

We understand building ready-to-assemble furniture can be a challenging experience for some. To help avoid confusion, we have provided some helpful tips that may speed up the process.

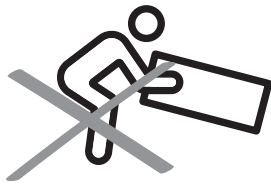

Teamwork

ALWAYS have at least two people to help with transporting and assembling the product to avoid potential injury and/or damage.

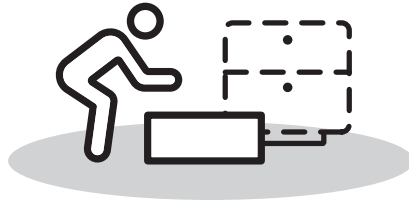
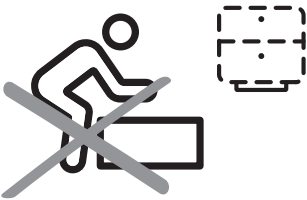

Suitable Location

Assembling near the area of the intended location is highly recommended.



Sufficient Space

Make sure you have enough space to move around during the assembly.

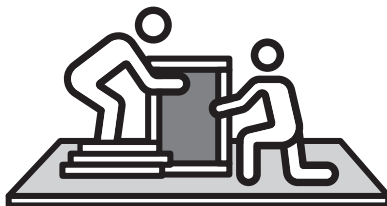

Avoid Scratches

Use cardboard, blankets or a carpeted area while assembling furniture to prevent to prevent scratches and damages.

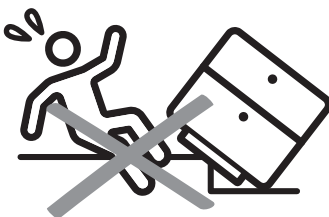

Flat Surface

Make sure the furniture rests on a flat and level surface with each leg evenly touching the floor.

ASSEMBLY AND CARE ADVICE



FAILURE TO FOLLOW THE GUIDELINES BELOW MAY RESULT IN INJURY AND/OR PROPERTY DAMAGE.



Position each part correctly and insert screws or bolts into their respective holes.

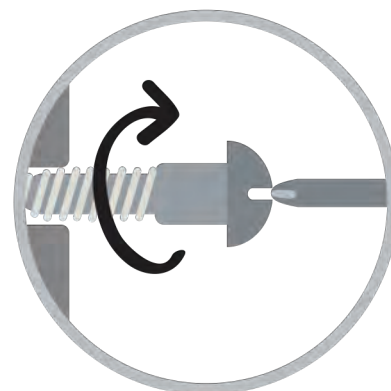

Turn clockwise to tighten and only tighten when step is completed or when instructed to do so.



Use the appropriate hand tools or power tools for assembly. Select steps, such as tightening screws and/or bolts, may require hand tools to avoid causing damage during assembly.



Save the instructions and store any supplied tools for later maintenance.

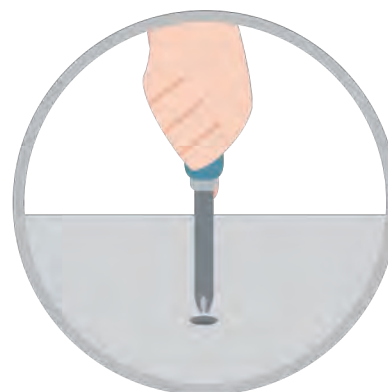

After two weeks, check and tighten any loose hardware and repeat again every six months thereafter.

IT IS THE USER'S RESPONSIBILITY TO MAINTAIN THE FURNITURE. THE HARDWARE MAY LOOSEN OVER TIME AND MAY CAUSE THE FURNITURE TO BE WOBBLY AND UNABLE TO SUPPORT ITS INTENDED WEIGHT CAPACITY. THIS MAY LEAD TO COLLAPSE AND MAY CAUSE SERIOUS INJURY.

BED

CM7056F/Q-VN



- Please keep instructions for future reference.
- Check the quantity and irregularity of parts and hardware before you start.

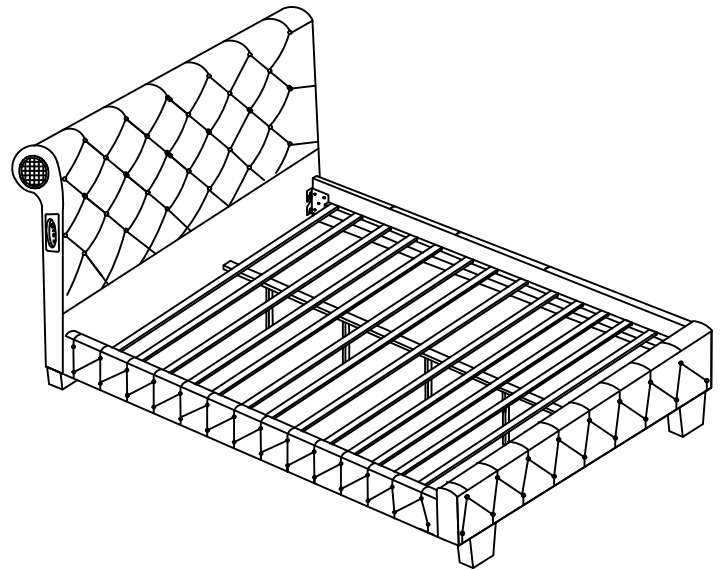

PARTS

#1 1pc

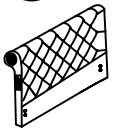

HeadBoard

#2 2pcs

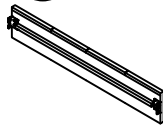

Side Rail

#3 1pc

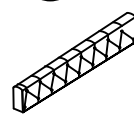

FootBoard

#4 1pc



Support Rail

#5 4pcs

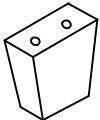

HB/FB Foot

#6 1set

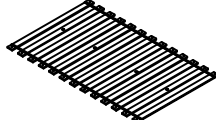

Slat (13pcs)

#7 4pcs Ø5/16"

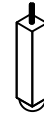

Support Leg 250x30x30mm

HARDWARE

#A 8pcs



Bolt
Ø5/16" x 1-1/2"

#B 8pcs

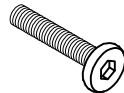

Bolt
Ø5/16" x 3"

#C 16pcs



Flat Washer
Ø5/16"x19mm

#D 16pcs



Lock Washer
Ø5/16"

#E 26pcs

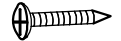

Screw
#8x38mm

#F 1pc



Allen Wrench 4mm

#G 1pc



Cable A

#H 1pc



Cable B

#I 1pc







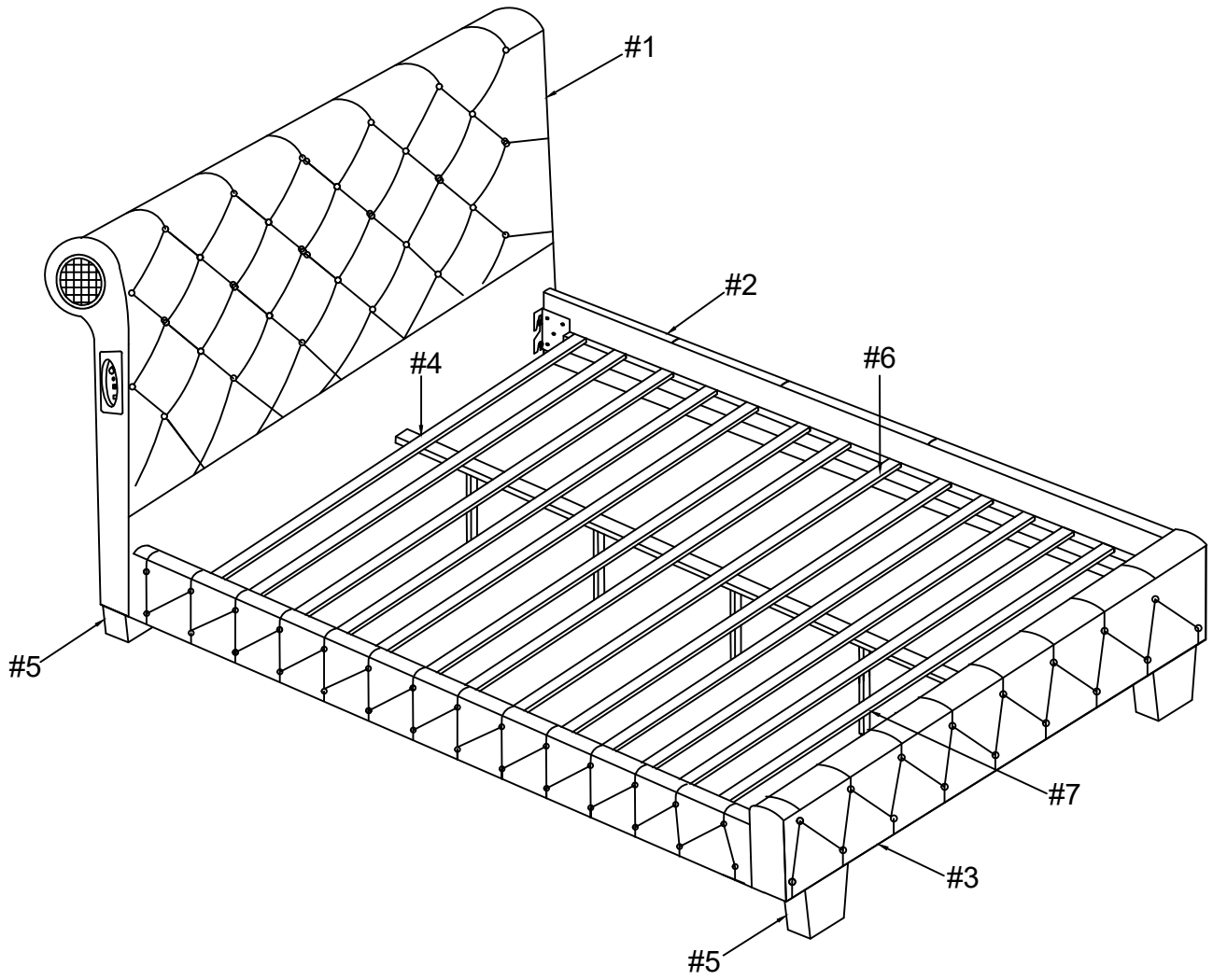



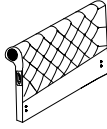

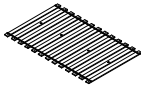
Power line

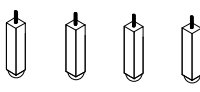
Exploded View

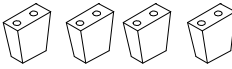

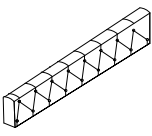
CM7056-Q/F is packed in 2 cases

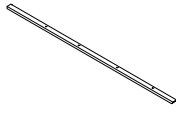
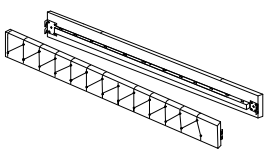
Carton	Disignation	Part		Hardware
CM7056-Q/F -HBFB	Headboard	#1		 #A x 8pcs  #B x 8pcs
	Slat (13pcs)	#6		 #C x 16pcs  #D x 16pcs
	Support leg(4pcs)	#7		 #E x 26pcs  #F x 1pc
	HB/FB Leg(4pcs)	#5		 #G x 1pc  #H x 1pc
	Footboard	#3		 #I x 1pc
CM7056-Q/F-R	Support Rail	#4		
	Side Rail(2pcs)	#2		

ASSEMBLY INSTRUCTIONS

Align legs (#5) to the headboard (#1), then secure by using bolts (#B) with washers (#D,C).

1

- Part #1 x1pc
- Part #5 x2pcs
- Hardware #B x4pcs
- Hardware #C x4pcs
- Hardware #D x4pcs

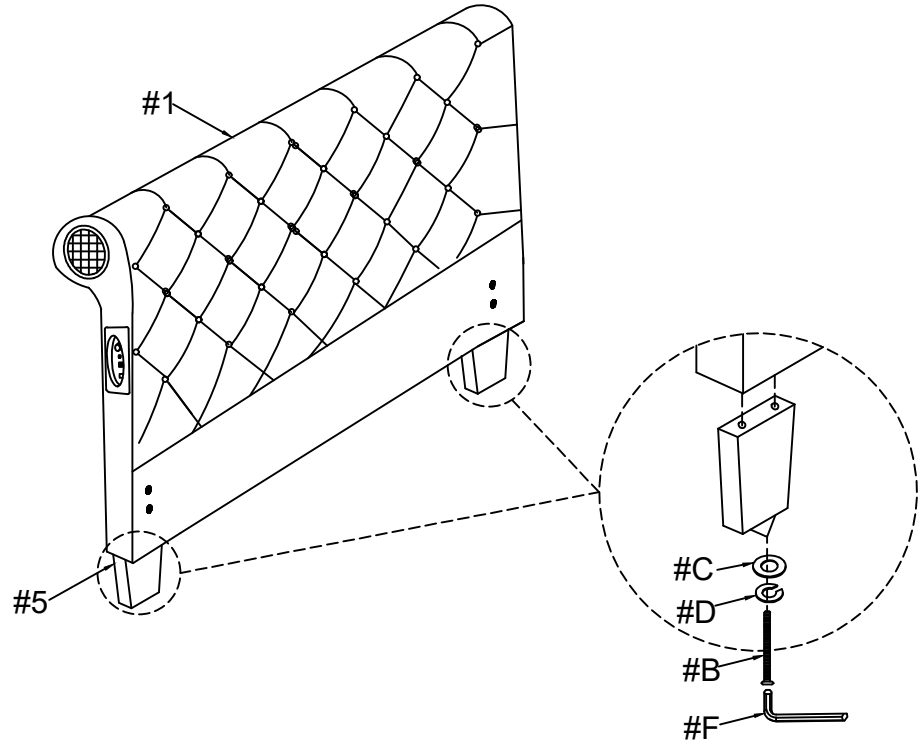

2

- Part #3 x1pc
- Part #5 x2pcs
- Hardware #B x4pcs
- Hardware #C x4pcs
- Hardware #D x4pcs

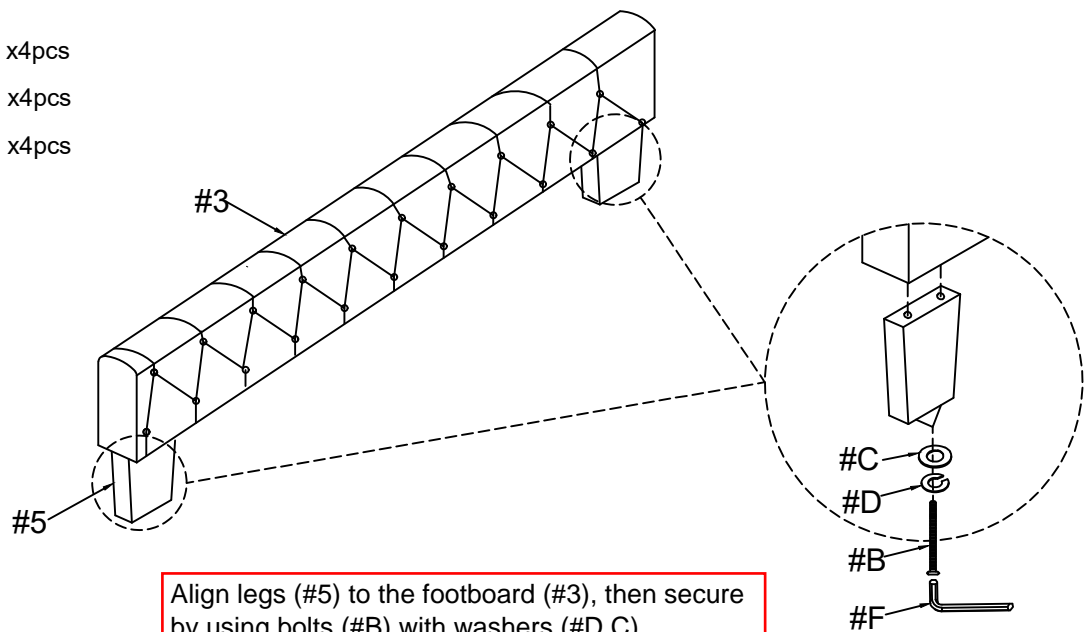

Align legs (#5) to the footboard (#3), then secure by using bolts (#B) with washers (#D,C).

ASSEMBLY INSTRUCTIONS

3

Align side rails (#2) to the headboard (#1) and footboard (#3), then secure by using bolts (#A) with washers (#D,C).

- Part #2 x2pcs
- Hardware #A x8pcs
- Hardware #C x8pcs
- Hardware #D x8pcs

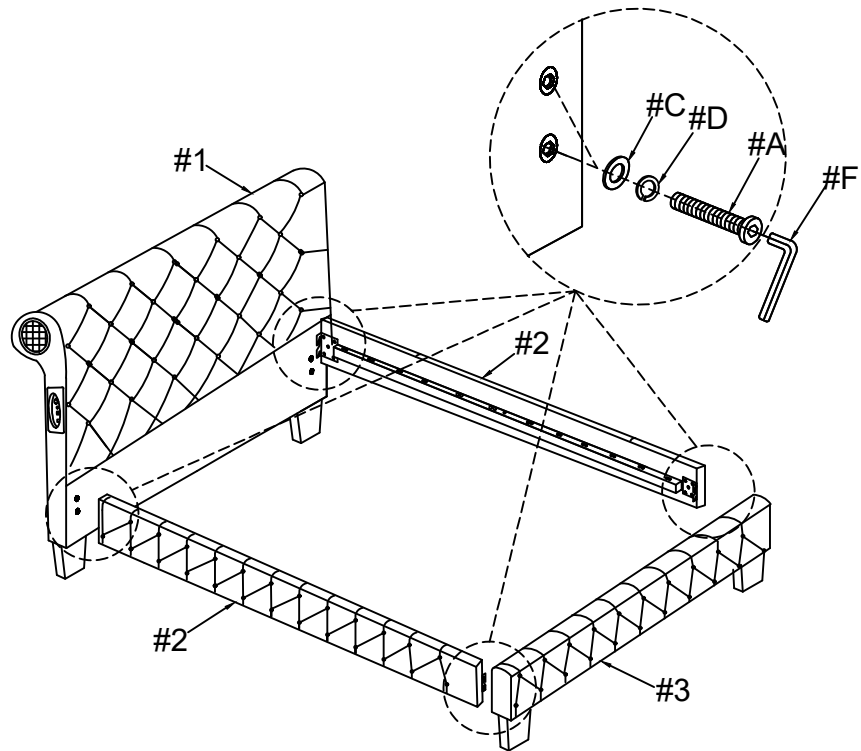

4

Align center slat (#4) to the slat kit (#6), then secure by using support legs (#7). Adjust the leveler on the support legs (#7) according to ground level.

- Part #4 x1pc
- Part #6 x1set
- Part #7 x4pcs

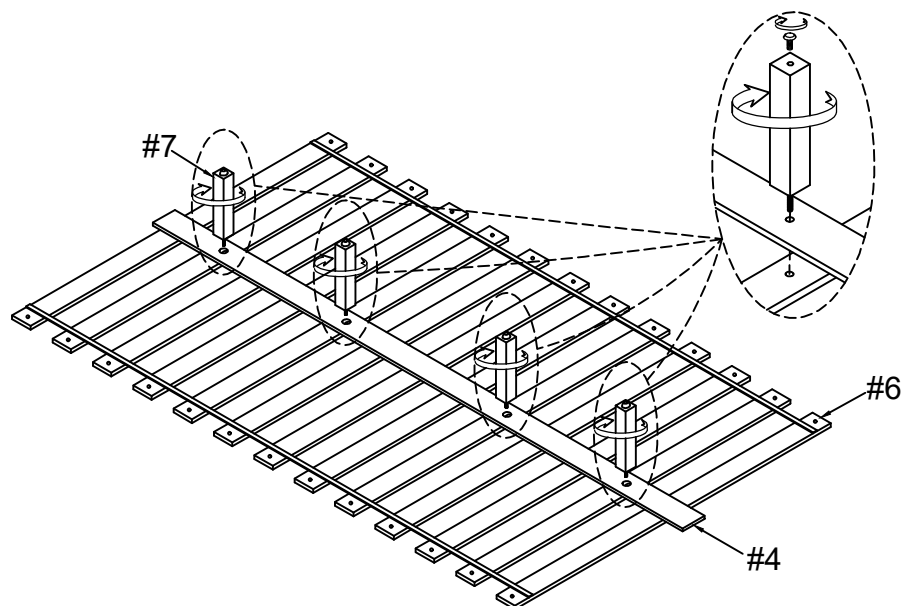

ASSEMBLY INSTRUCTIONS

5

Align slat kit (#6) to the side rails (#2), then secure by using screws (#E).

Hardware #E x26pcs

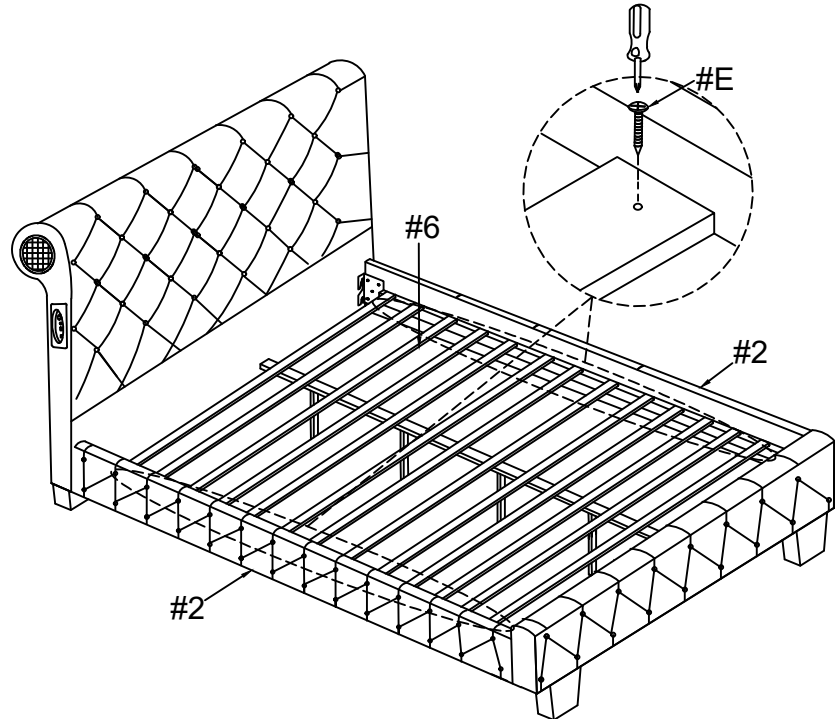

6

Hardware #G x1pc

Hardware #H x1pc

Hardware #I x1pc

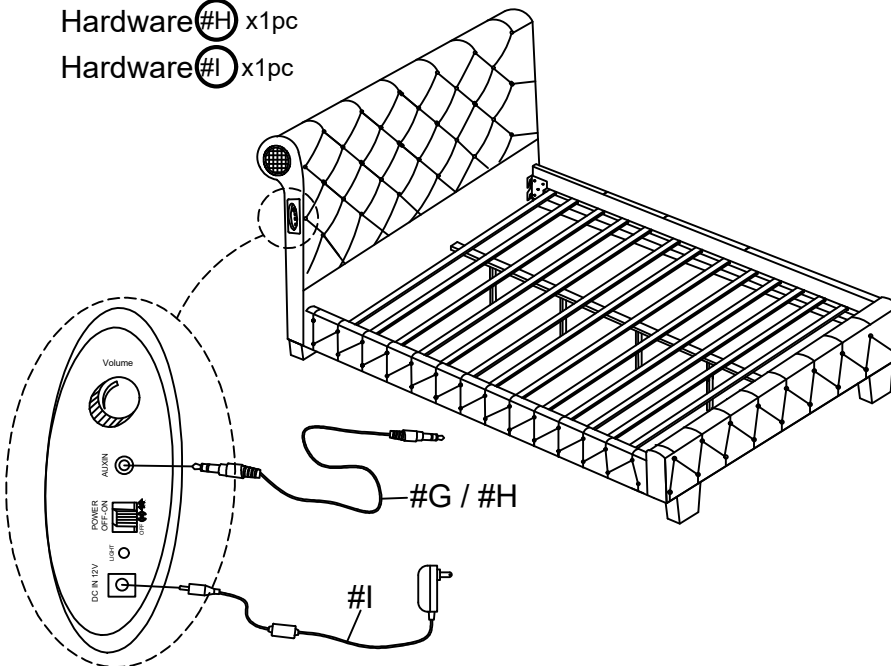

ASSEMBLY COMPLETED



Please ensure the furniture rests on an even and flat surface. If the product wobbles or feels loose, double-check all bolts and/or screws are properly tightened and secured.

✓ Keep this handy!

Please retain this instruction manual and any order-related information for future reference.

✓ Lift, don't drag!

To avoid damage to product please always LIFT the product when transporting or adjusting the placement.