

Assembly Instructions

CM3776T

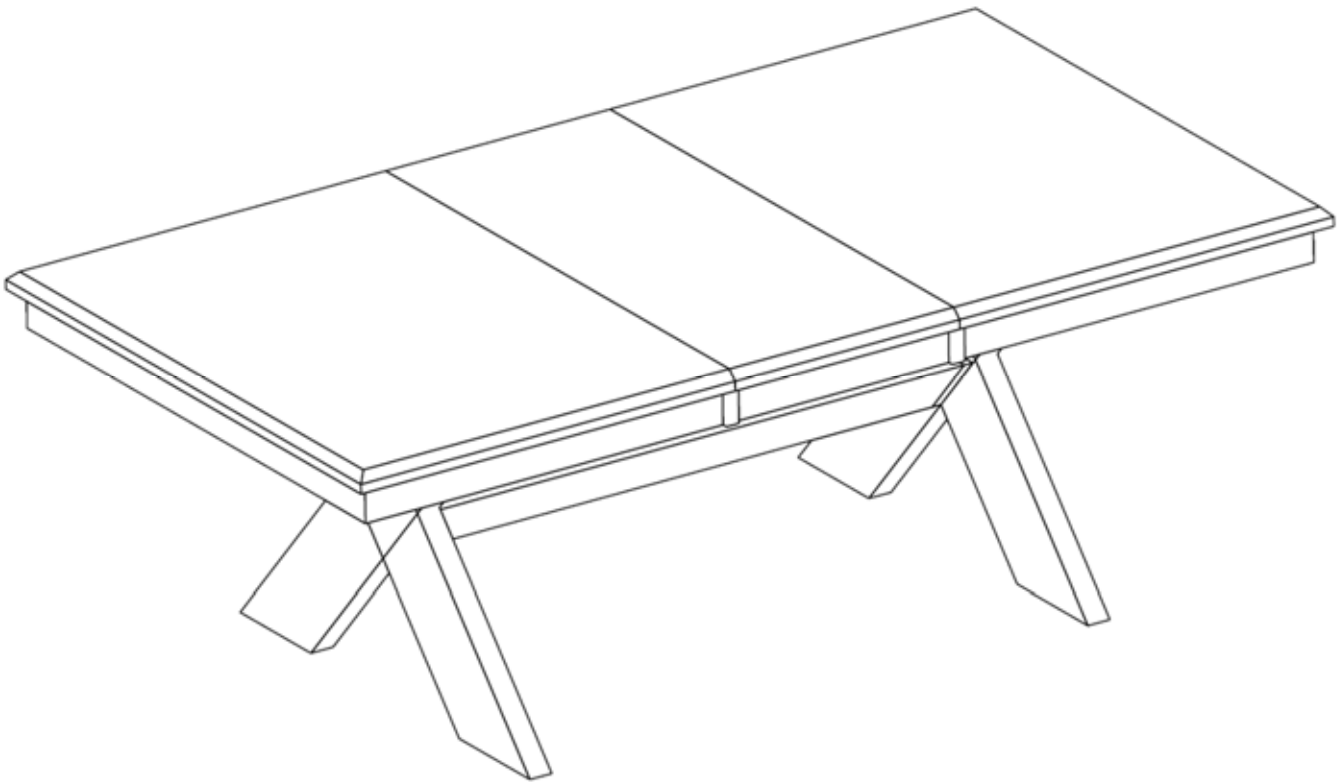

ASSEMBLY RATING

The Assembly Rating is a 5-point system that shows the degree of effort needed in assembling a specific product (with 1 being easy and 5 being difficult). For some products, two persons are recommended.

EASY  DIFFICULT

Tools Required for Assembly:

Allen Wrench



Wrench



2 PERSONS RECOMMENDED

ASSEMBLY & CARE ADVICE

FOR YOUR FURNITURE TO LAST, CORRECT ASSEMBLY AND PROPER MAINTENANCE ARE NECESSARY. PLEASE FOLLOW THE INFORMATION PROVIDED BELOW TO FULLY ENJOY YOUR FURNITURE.

BASIC ASSEMBLY TECHNIQUES

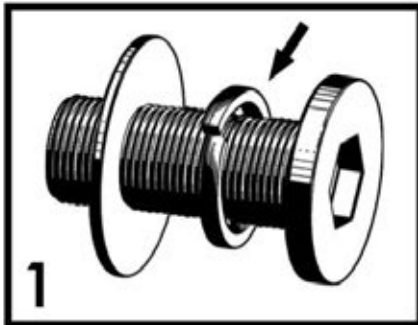

1 When lock or spring washer is used in an assembly, please make sure the lock or spring washer is placed between the larger flat washer and the head of the screw or bolt.



2 Position each part correctly and insert screws or bolts into their respective holes by hand tighten or using the proper hand tool. Only tighten when step is completed or when instructed to do so.



3 Use cardboard or carpet area when assembling furniture to prevent scratches. Make sure the furniture rests on a flat and level surface with each leg evenly touching the floor.

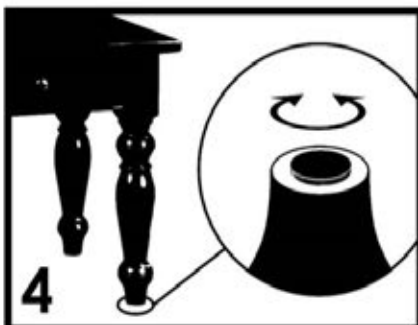

4 Some furniture comes with height adjustment knobs underneath each leg. To lower or to raise each leg, you need to turn clockwise or counterclockwise, respectively.

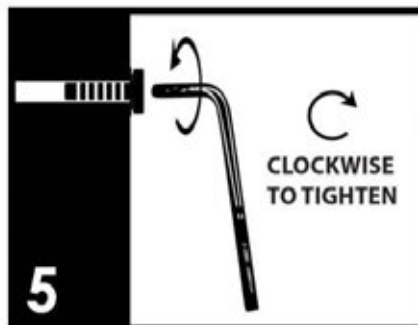

5 Make sure all parts are properly aligned, then use the appropriate hand tool to completely tighten the bolts or screws. Do not use power tools and do not overtighten.

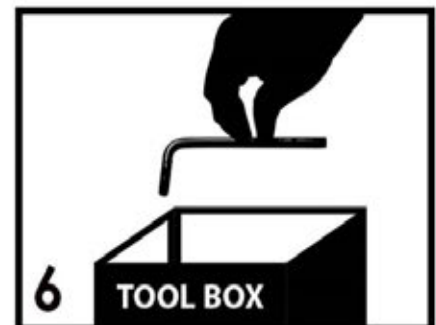

6 Save the instructions and store the Allen wrench or any supplied tool for later maintenance. After two weeks, check and tighten any loose hardware and repeat again every six months thereafter.

IT IS THE USER'S RESPONSIBILITY TO MAINTAIN THE FURNITURE. THE HARDWARE MAY LOOSEN OVER TIME AND MAY CAUSE THE FURNITURE TO BE WOBBLY AND UNABLE TO SUPPORT ITS INTENDED WEIGHT CAPACITY. THIS MAY LEAD TO COLLAPSE AND MAY CAUSE SERIOUS INJURY.



FAILURE TO FOLLOW THE GUIDELINES ABOVE MAY RESULT IN INJURY AND/OR PROPERTY DAMAGE.



Before you begin, please read Page 2 of “Assembly and Care Advice”.

And remember, do not tighten until each step is completed or instructed.

MD

Parts List



#1 x 1 pc
Table Top



#2 x 2 pcs
Leg



#3 x 1 pc
Leg Support Rail

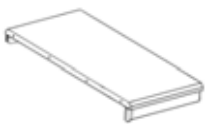

#4 x 1 pc
Table Leaf

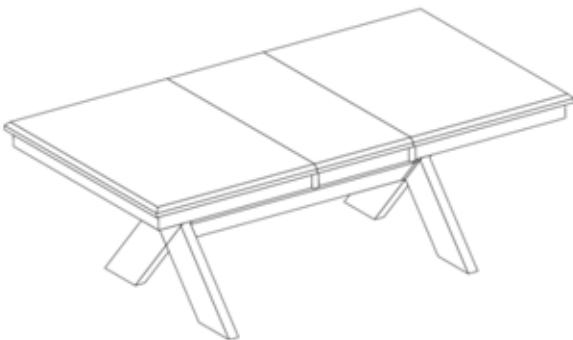

Hardware List



#A x 8 pcs
Flat Washer 5/16”



#B x 8 pcs
Lock Washer 5/16”



#C x 4 pcs
Hex Nut



#D x 4 pcs
Bolt 5/16”x1-1/2”



#E x 1 pc
Allen Wrench



#F x 1 pc
Flat Wrench



Due to the size and weight of this product, it is highly recommended that the assembly should be done near the area of its intended location. Make sure you have enough space to move around during the assembly. ALWAYS have at least two people to help with transporting and assembling the product and to avoid any potential injury and/or damage.

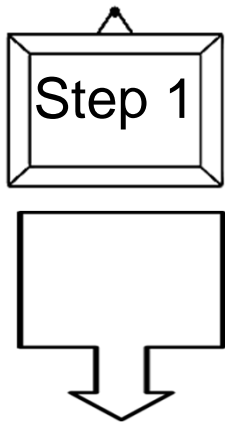

- I. Align the two pre-drilled holes of the leg support rail (#3) onto the two pre-drilled holes of the leg (#2).
- II. Prepare two bolt assemblies by inserting FIRST the lock washer (#B) onto the bolt (#D) and then the flat washer (#A) onto the SAME bolt (#D), in that order.
- III. Insert the bolt assemblies through the two holes of the leg support rail (#3) and secure those bolts using the Allen wrench (#E) to lock it in with the leg (#2). Repeat the process for the other leg.

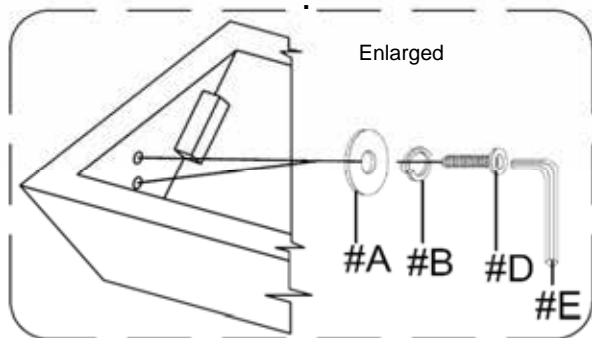

Turn right (clockwise) to tighten

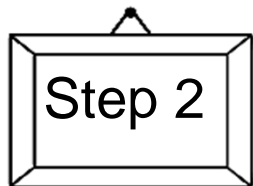
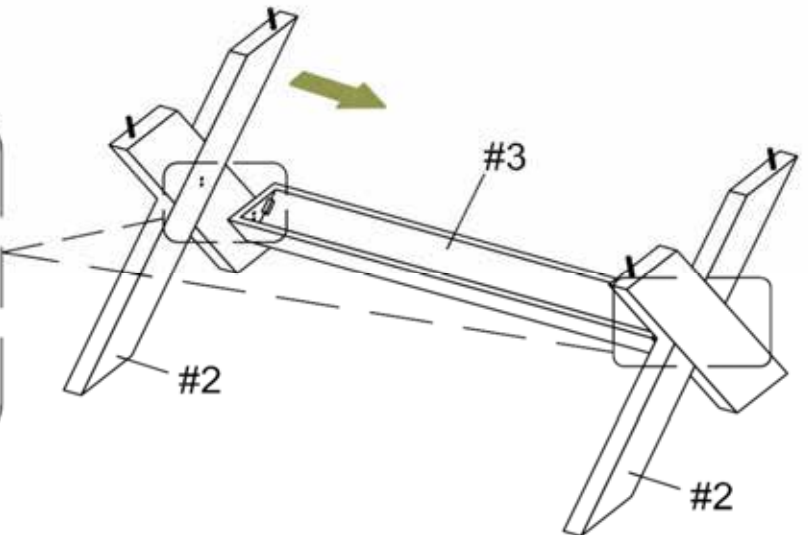

#A x 4 pcs
#B x 4 pcs
#C x 4 pcs

- I. With the help of another person, carefully align the table top (#1) onto the 4 threaded studs of the legs (#2).
- II. For each threaded studs, insert the flat washer (#A) FIRST and then a lock washer (#B). Then secure that assembly with a hex nut (#C) using a flat wrench (#F) to lock the two parts together.
- III. Repeat the process for the remaining 3 threaded stud locations.

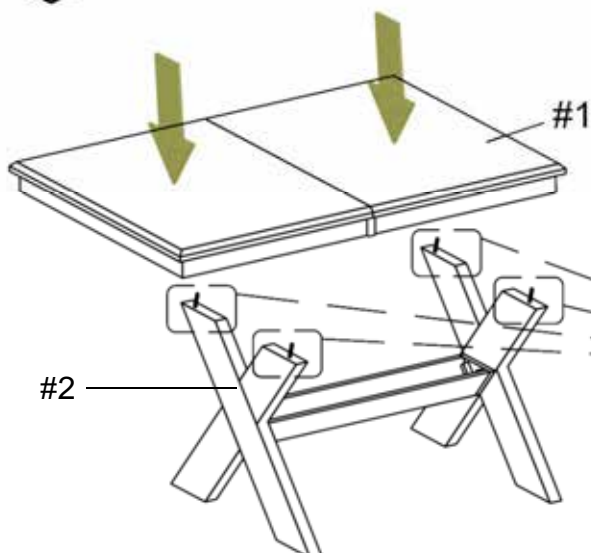

Turn right (clockwise) to tighten

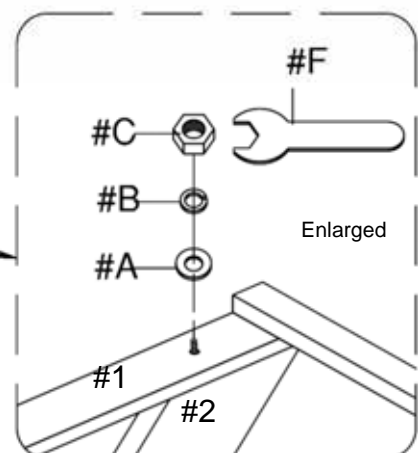

Step 3

- I. To extend the table, unlock the two tension-lever locking latches located under the table.
- II. Once unlocked, slide outward on both ends of the two-piece table top until there is sufficient opening for the table leaf (#4).
- III. Carefully place the table leaf (#4) onto the open space of the table top (#1).
- IV. Slide inward on both ends of the two-piece table top until they are touching and sitting flush with the table leaf (#4).
- V. Secure the tension-lever locking latches at the four points under the table leaf to lock each side of the two-piece table top.

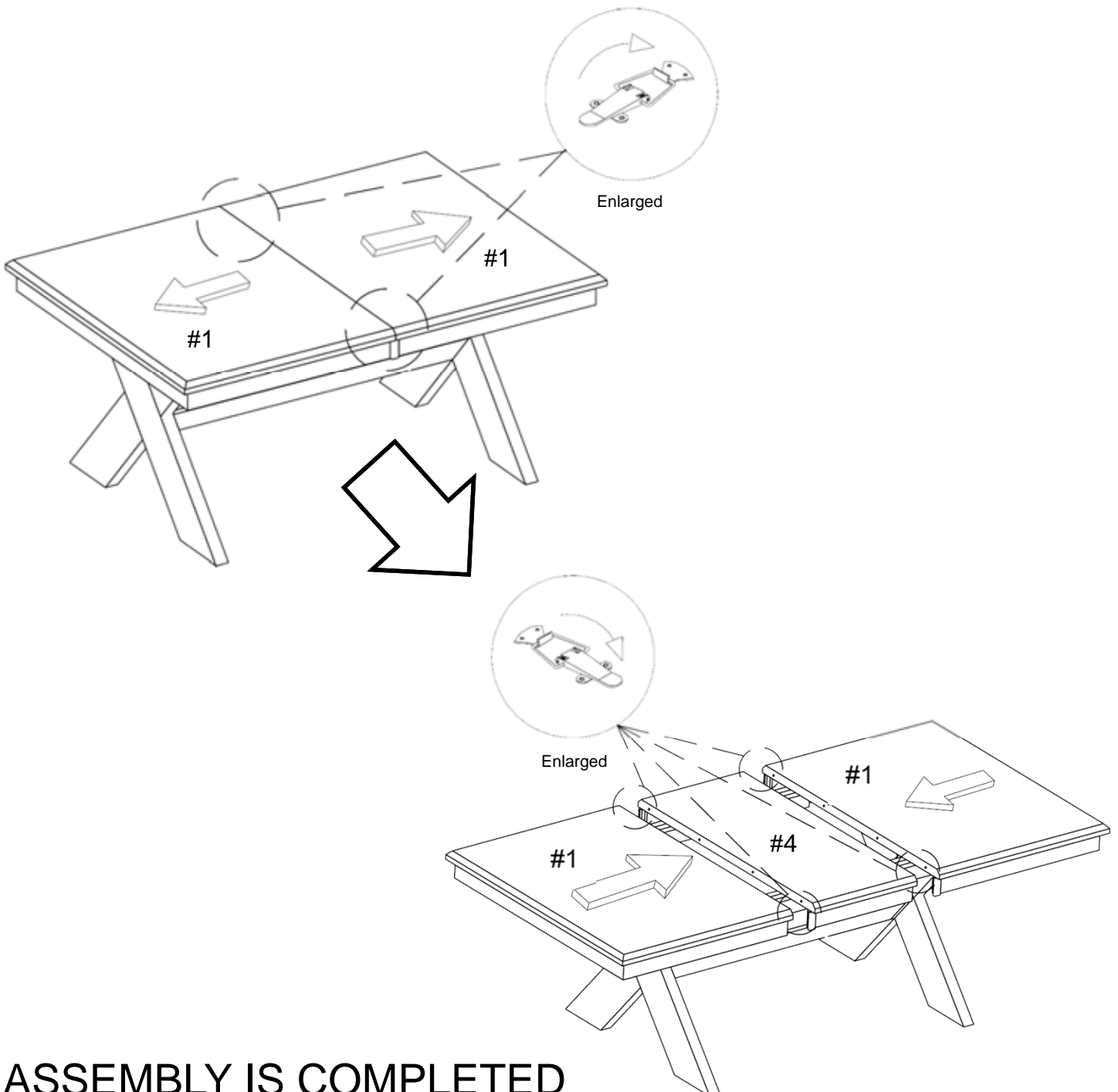

ASSEMBLY IS COMPLETED