

# Assembly Instructions

## CM3557CH-RT

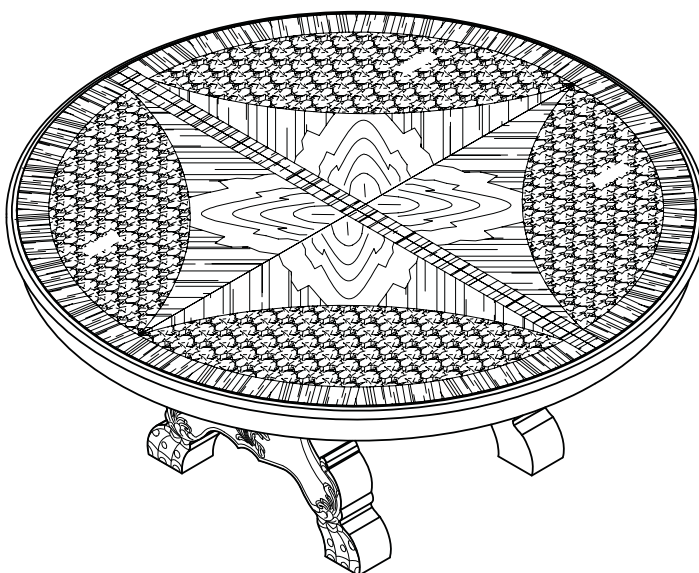

### ASSEMBLY RATING

The Assembly Rating is a 5-point system that shows the degree of effort needed in assembling a specific product (with 1 being easy and 5 being difficult). For some products, two persons are recommended.

EASY  DIFFICULT

### Tools Required For Assembly:

Allen Wrench

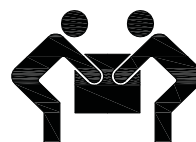
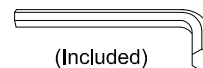

2 PERSONS RECOMMENDED

# ASSEMBLY & CARE ADVICE

FOR YOUR FURNITURE TO LAST, CORRECT ASSEMBLY AND PROPER MAINTENANCE ARE NECESSARY. PLEASE FOLLOW THE INFORMATION PROVIDED BELOW TO FULLY ENJOY YOUR FURNITURE.

## BASIC ASSEMBLY TECHNIQUES

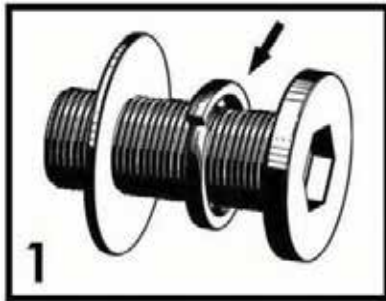

1  
When lock or spring washer is used in an assembly, please make sure the lock or spring washer is placed between the larger flat washer and the head of the screw or bolt.



2  
Position each part correctly and insert screws or bolts into their respective holes by hand tighten or using the proper hand tool. Only tighten when step is completed or when instructed to do so.



3  
Use cardboard or carpet area when assembling furniture to prevent scratches. Make sure the furniture rests on a flat and level surface with each leg evenly touching the floor.

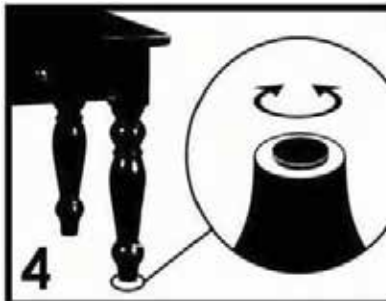

4  
Some furniture comes with height adjustment knobs underneath each leg. To lower or to raise each leg, you need to turn clockwise or counterclockwise, respectively.

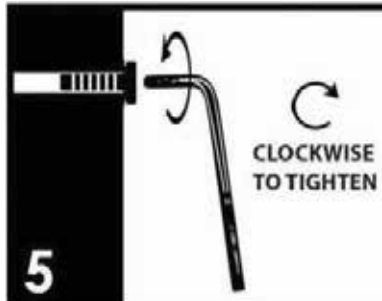

5  
Make sure all parts are properly aligned, then use the appropriate hand tool to completely tighten the bolts or screws. Do not use power tools and do not overtighten.

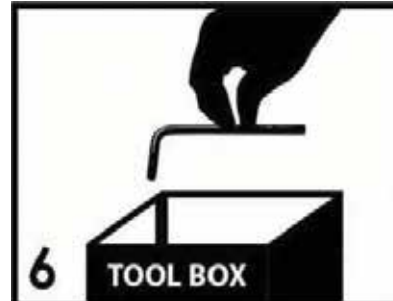

6  
Save the instructions and store the Allen wrench or any supplied tool for later maintenance. After two weeks, check and tighten any loose hardware and repeat again every six months thereafter.

IT IS THE USER'S RESPONSIBILITY TO MAINTAIN THE FURNITURE. THE HARDWARE MAY LOOSEN OVER TIME AND MAY CAUSE THE FURNITURE TO BE WOBBLY AND UNABLE TO SUPPORT ITS INTENDED WEIGHT CAPACITY. THIS MAY LEAD TO COLLAPSE AND MAY CAUSE SERIOUS INJURY.

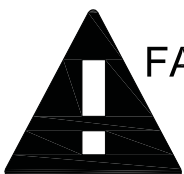





**FAILURE TO FOLLOW THE GUIDELINES ABOVE MAY RESULT IN INJURY AND/OR PROPERTY DAMAGE.**





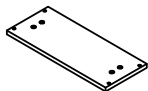
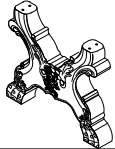

Before you begin, please read Page 2 of "Assembly and Care Advice".

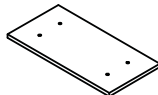
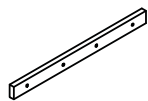
And remember, do not tighten until each step is completed or instructed.

### Parts List

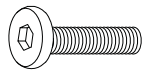
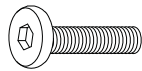
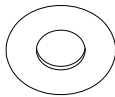
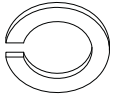
-  #1 x 1pc  
Table Top
-  #2 x 1pc  
Table Top
-  #3 x 2pcs  
Table Top Support Panel
-  #4 x 2pcs  
Leg
-  #5 x 1pc  
Leg Support
-  #6 x 1pc  
Table Top connect Panel
-  #7 x 2pcs  
Table Top connect Rail

### Hardware List

-  #A x 24pcs  
Bolt Ø5/16"X2"
-  #B x 4pc  
Bolt Ø5/16"X1-1/4"
-  #C x 30pcs  
Flat Washer
-  #D x 30pcs  
Lock Washer
-  #E x 1pc  
Allen Wrench M5
-  #F x 2pcs  
Bolt Ø5/16"X2-3/4"
-  #G x 2pcs  
Half Round Washer
-  #H x 2pcs  
Nut
-  #I x 1pc  
Wrench



#1

#A x 8pcs  
#C x 8pcs  
#D x 8pcs

1. Prepare 8 bolt assemblies by first inserting a lock washer (#D) onto the bolt (#A) then a flat washer (#C) onto that same bolt (#A).

2. Place the table top support panel (#3) onto the legs (#4), then insert 4 bolt assemblies into each panel. Secure using the Allen wrench (#E).

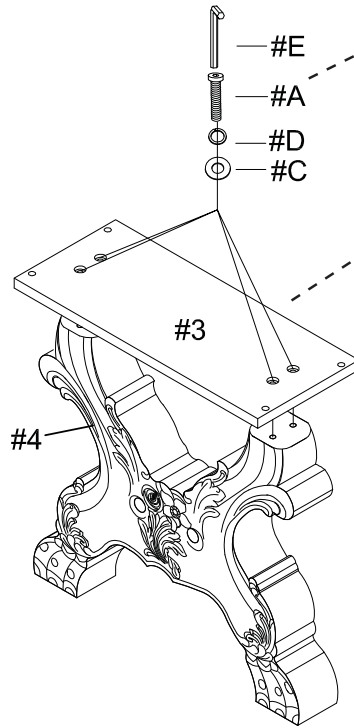

x 2



#2

#C x 2pcs  
#D x 2pcs  
#F x 2pcs  
#G x 2pcs  
#H x 2pcs

1. Turn the legs face down.

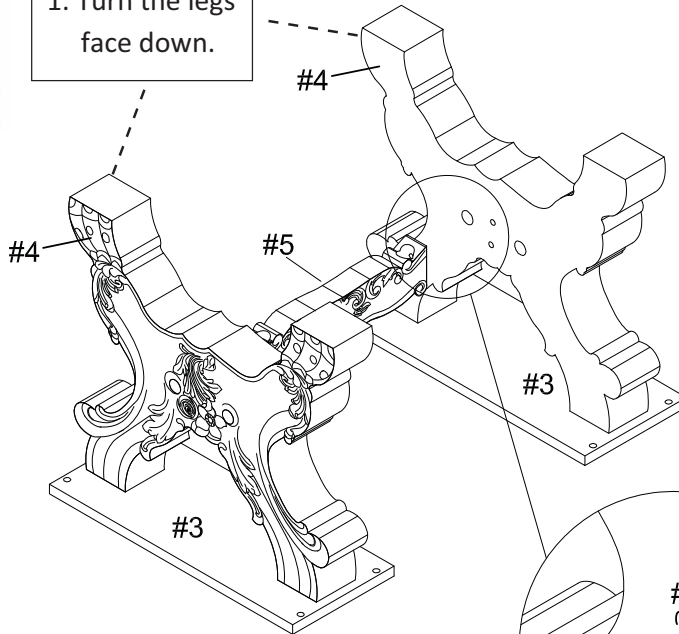

2. Insert a bolt (#F) into the hole along the side of the legs (#4), shown below. Turn right to tighten.

3. Apply the leg support (#5) onto those bolts (#F), then apply a half round washer (#G), flat washer (#C), lock washer (#D), and nut (#H). In that order. Secure using the wrench.

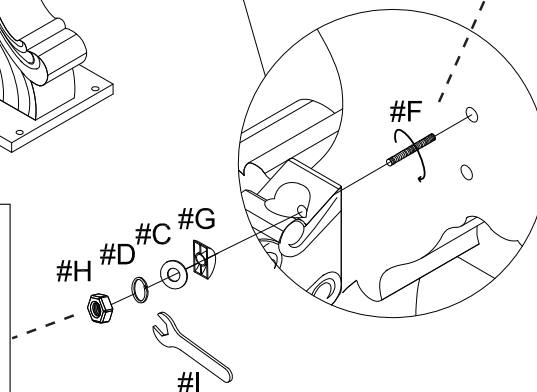



#A x 8pcs  
 #B x 4pcs  
 #C x 12pcs  
 #D x 12pcs

1. Place the table tops (#1,2) face down onto a protected surface, then secure by locking the latches.

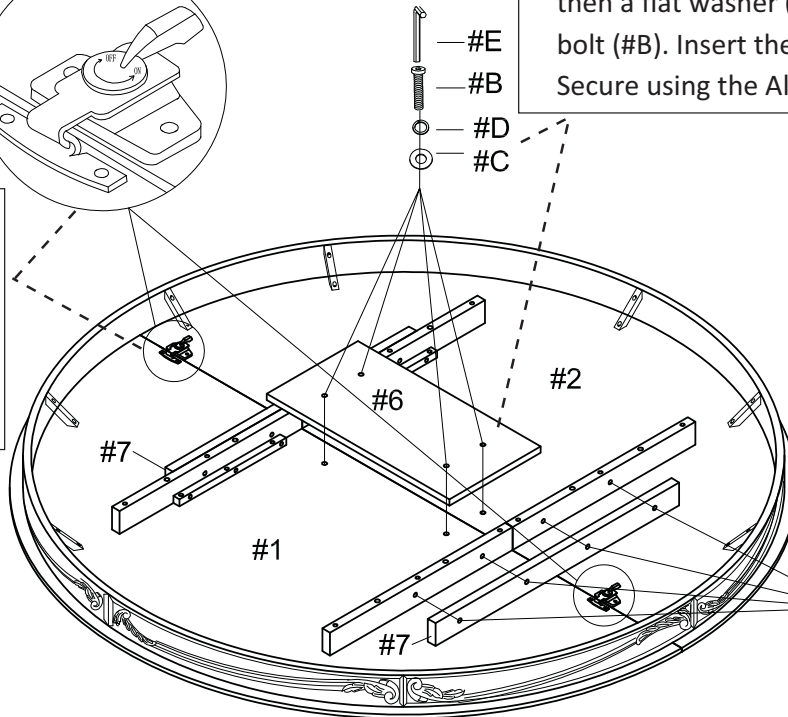
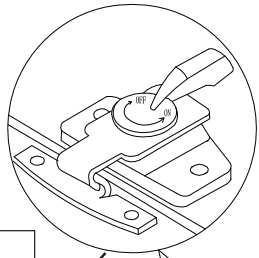

2. Place the table top connect panel (#6) onto the center of the table tops (#1,2). Prepare 4 bolts assemblies by first inserting a lock washer (#D) onto the bolt (#B) then a flat washer (#C) onto that same bolt (#B). Insert the bolts into the panels. Secure using the Allen wrench (#E).

3. Align the connect rails (#7) to the holes displayed above. Prepare 8 bolt assemblies by first inserting a lock washer (#D) onto the bolt (#A) then a flat washer (#C) onto that same bolt (#A). Insert into the holes and secure using the Allen wrench (#E).



#A x 8pcs  
 #C x 8pcs  
 #D x 8pcs

1. Place the table top support panel (#3) face down onto the connect rails (#7) and align the holes.

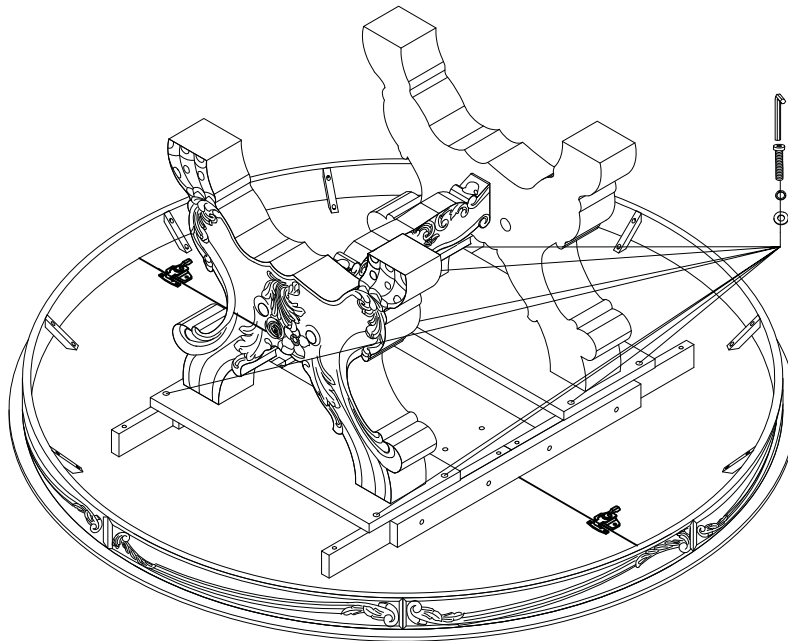

2. Prepare 8 bolt assemblies by first inserting a lock washer (#D) onto the bolt (#A) then a flat washer (#C) onto that same bolt (#A). Insert a bolt into each bolt Secure using the Allen wrench (#E).

**ASSEMBLY IS COMPLETED**