

# ASSEMBLY INSTRUCTIONS

MODEL #

CM3387T

Questions?

GIVE US CALL: 1-888-980-5122  
MON-FRI 8:30AM - 5:30PM (PST)

## TOOLS REQUIRED



Allen Wrench

(Included)

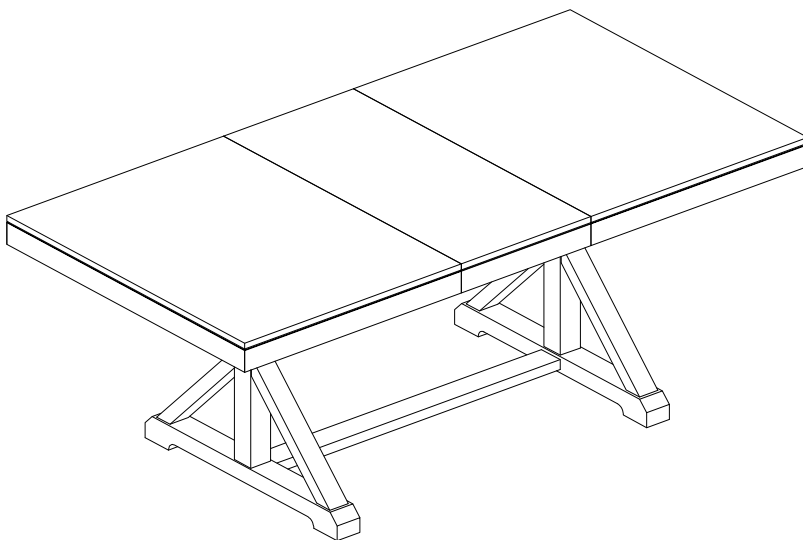

2 - People  
Recommended

## ASSEMBLY RATING



EASY —————> DIFFICULT

The Assembly Rating is a 5-point system showing the level of effort needed to assemble a specific product.



FOA Intro

Thank you for your purchase!

We hope you enjoy this new addition to your home for many years to come.

Our commitment to providing quality products does not simply end when you purchase our product. We fully stand behind our products from start to finish. Our customer service department is available Monday – Friday 8:30 AM – 5:30 PM Pacific and can help with assembly questions as well as, if necessary, replacing damaged or missing parts. To help expedite our service, please have these assembly instructions readily available, along with your order receipt.

 **Consumer Hotline**  
Toll-Free 1-888-980-5122

 **Monday to Friday**  
8:30AM- 5:30PM (PST)

 **WEBSITE**  
[www.foagroup.com](http://www.foagroup.com)

 **E-MAIL**  
[cs.ec@foagroup.com](mailto:cs.ec@foagroup.com)

    foagroup

 FurnitureOfAmerica

---

## CHECK BEFORE STARTING

**Are you missing anything?**

Double-check all parts, hardware and accessories listed on Page 6 are accounted for.

**Check out our Quick Tips!**

We recommend reviewing the pre-assembly handouts. Even experts need a refresher now and then!

**Should we send any replacements?**

Are there any irregularities or flaws in the parts? We can send replacements!

**Prep Time!**

Please review the assembly instructions and all diagrams prior to assembling. Arrange parts as recommended on Page 7 and group identical hardware together to make assembling easier.

# PRE ASSEMBLY INTRODUCTION

We understand building ready-to-assemble furniture can be a challenging experience for some. To help avoid confusion, we have provided some helpful tips that may speed up the process.



## Teamwork

ALWAYS have at least two people to help with transporting and assembling the product to avoid potential injury and/or damage.



## Suitable Location

Assembling near the area of the intended location is highly recommended.



## Sufficient Space

Make sure you have enough space to move around during the assembly.



## Avoid Scratches

Use cardboard, blankets or a carpeted area while assembling furniture to prevent scratches.



## Flat Surface

Make sure the furniture rests on a flat and level surface with each leg evenly touching the floor.

# ASSEMBLY AND CARE ADVICE



**FAILURE TO FOLLOW THE GUIDELINES BELOW MAY RESULT IN INJURY AND/OR PROPERTY DAMAGE.**



Position each part correctly and insert screws or bolts into their respective holes.



Turn clockwise to tighten and only tighten when step is completed or when instructed to do so.



Use the appropriate hand tools or power tools for assembly. Select steps, such as tightening screws and/or bolts, may require hand tools to avoid causing damage during assembly.



Save the instructions and store any supplied tools for later maintenance.



After two weeks, check and tighten any loose hardware and repeat again every six months thereafter.

**IT IS THE USER'S RESPONSIBILITY TO MAINTAIN THE FURNITURE. THE HARDWARE MAY LOOSEN OVER TIME AND MAY CAUSE THE FURNITURE TO BE WOBBLY AND UNABLE TO SUPPORT ITS INTENDED WEIGHT CAPACITY. THIS MAY LEAD TO COLLAPSE AND MAY CAUSE SERIOUS INJURY.**

# TABLE

CM3387T



- Please keep instructions for future reference.
- Check the quantity and irregularity of parts and hardware before you start.

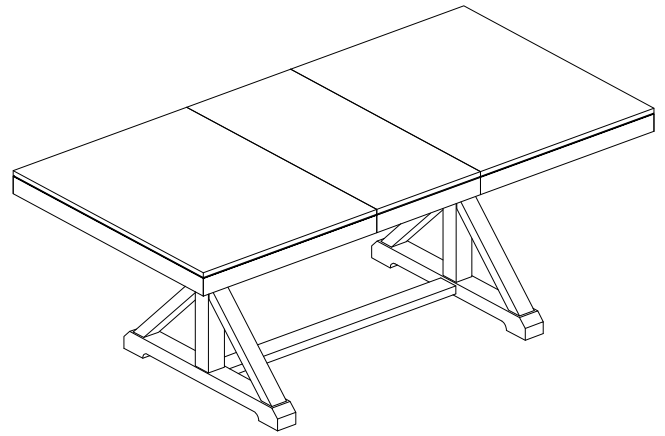

## PARTS

#1 1pc

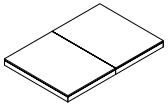

Table Top

#2 1pc

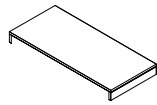
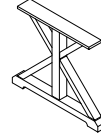

Table Leaf

#3 2pcs



Leg

#4 1pc

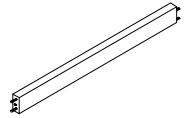

Up Crossbar

#5 1pc

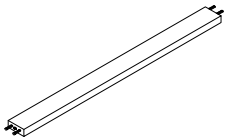

Bottom Crossbar

## HARDWARE

#A 8pcs

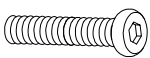

Bolt  
Ø5/16" x 1-1/2"

#B 4pcs

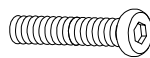

Bolt  
Ø5/16" x 2-3/4"

#C 12pcs



Lock Washer  
Ø5/16"

#D 12pcs



Flat Washer  
Ø5/16"

#E 1pc



Allen Key 4mm







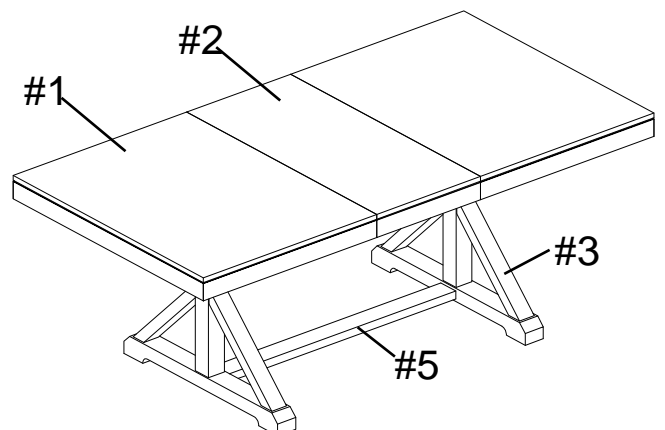

#F 4pcs

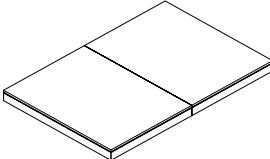

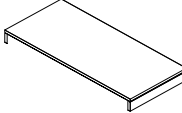
Wood Nut

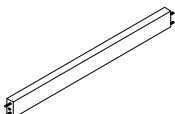

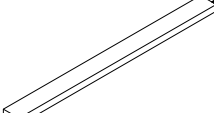
## CM3387T is packed in 2 cases

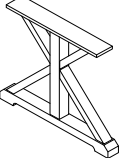
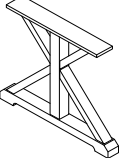
Carton	Disignation		Part	Hardware
CM3387T-1	Table Top	#1		 #A x8pcs  #B x 4pcs
	Table Leaf	#2		 #C x12pcs  #D x12pcs
	Up Crossbar	#4		 #F x1pc
	Bottom Crossbar	#5		 #E x4pcs
CM3387T-2	Leg	#3	 	

# ASSEMBLY INSTRUCTIONS

## 1

- Part #3 x 2pcs
- Part #4 x 1pc
- Part #5 x 1pc
- Hardware #B x 8pcs
- Hardware #C x 8pcs
- Hardware #D x 8pcs
- Hardware #F x 8pcs

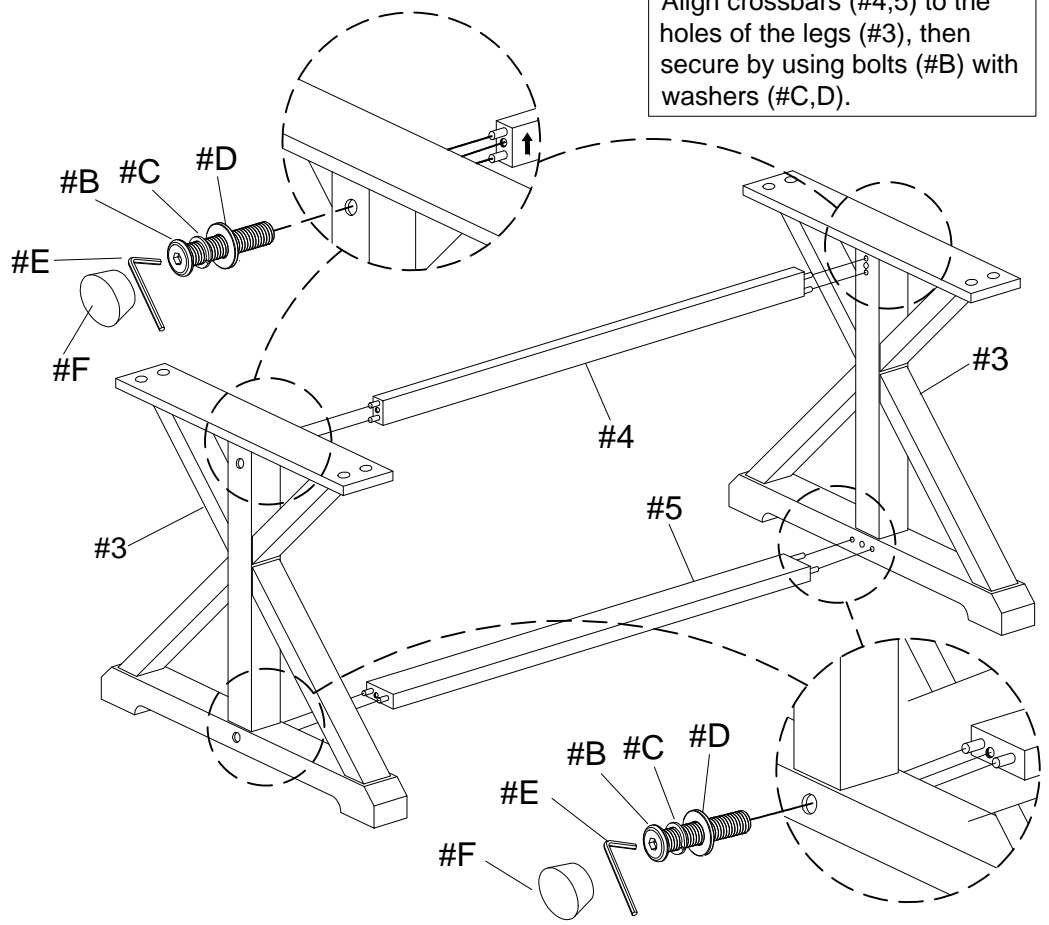

Align crossbars (#4,5) to the holes of the legs (#3), then secure by using bolts (#B) with washers (#C,D).

## 2

- Part #1 x 1pc
- Hardware #A x 8pcs
- Hardware #C x 8pcs
- Hardware #D x 8pcs

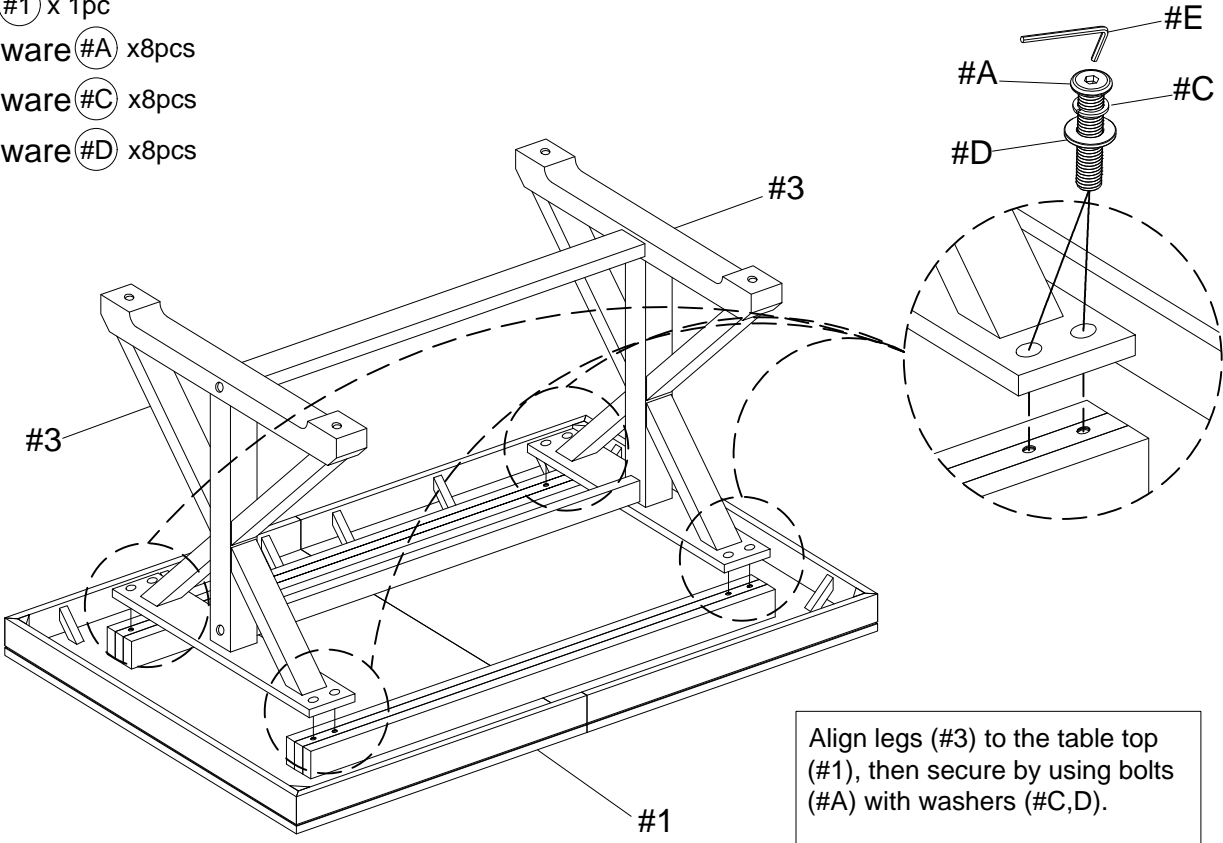

Align legs (#3) to the table top (#1), then secure by using bolts (#A) with washers (#C,D).

# ASSEMBLY INSTRUCTIONS

3

1) Turn lever to open from underneath the table.

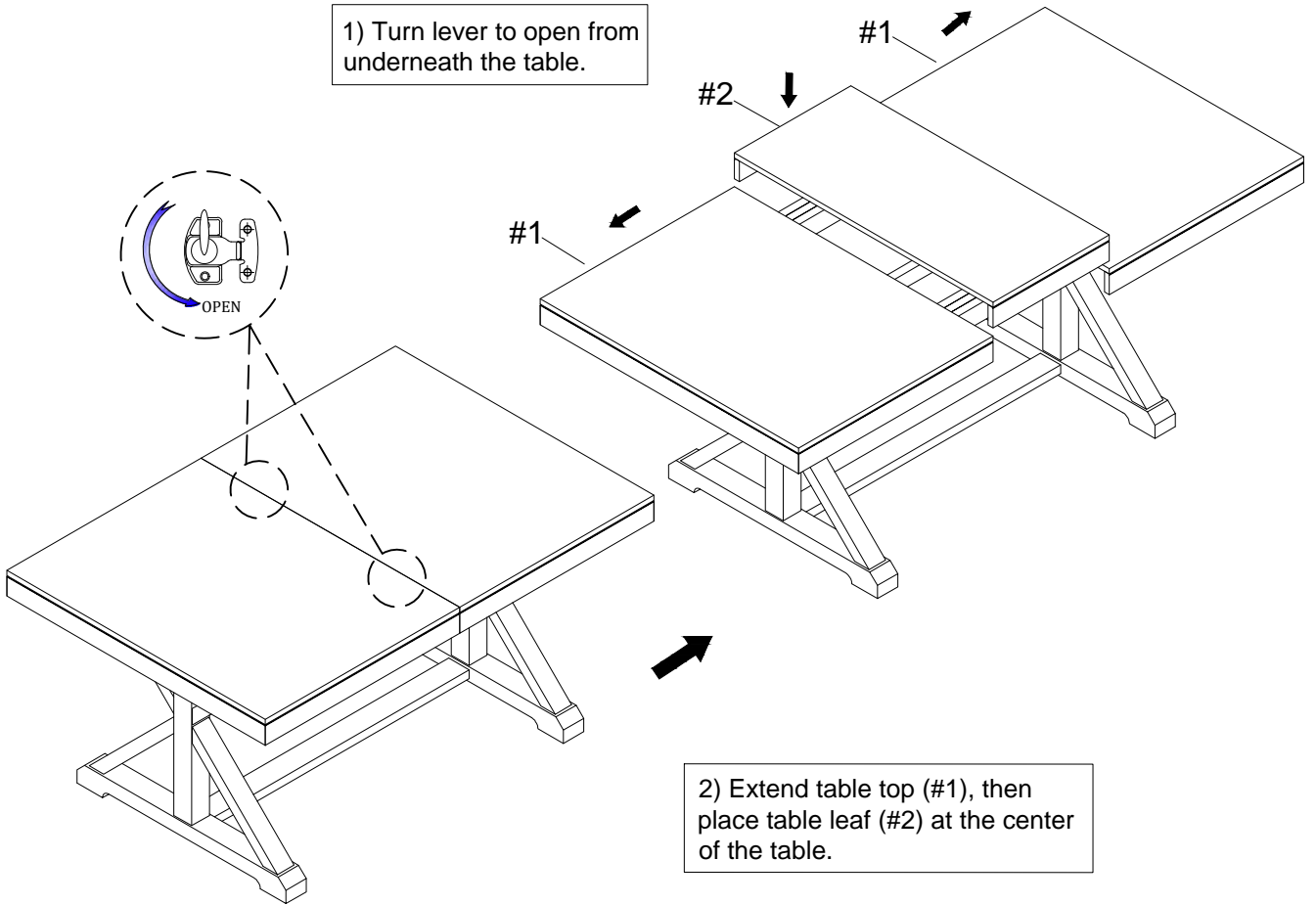

2) Extend table top (#1), then place table leaf (#2) at the center of the table.

4

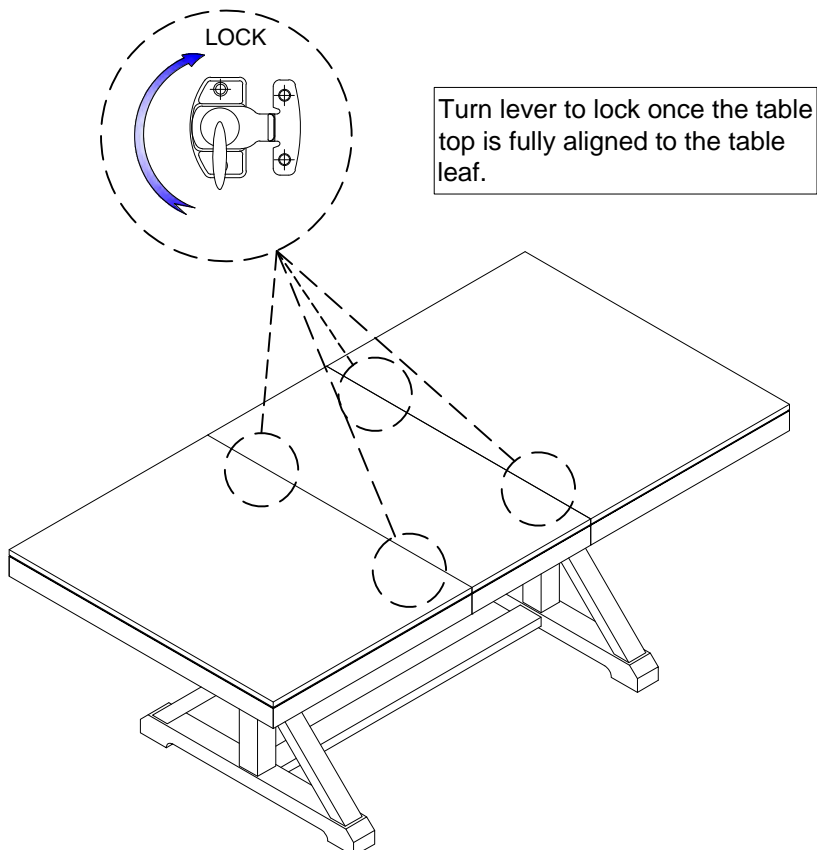

## ASSEMBLY COMPLETED



Please ensure the furniture rests on an even and flat surface. If the product wobbles or feels loose, double-check all bolts and/or screws are properly tightened and secured.



### Keep this handy!

Please retain this instruction manual and any order-related information for future reference.



### Lift, don't drag!

To avoid damage to product please always LIFT the product when transporting or adjusting the placement.