

Furniture of America®

Assembly Instructions

CM3326WC-T

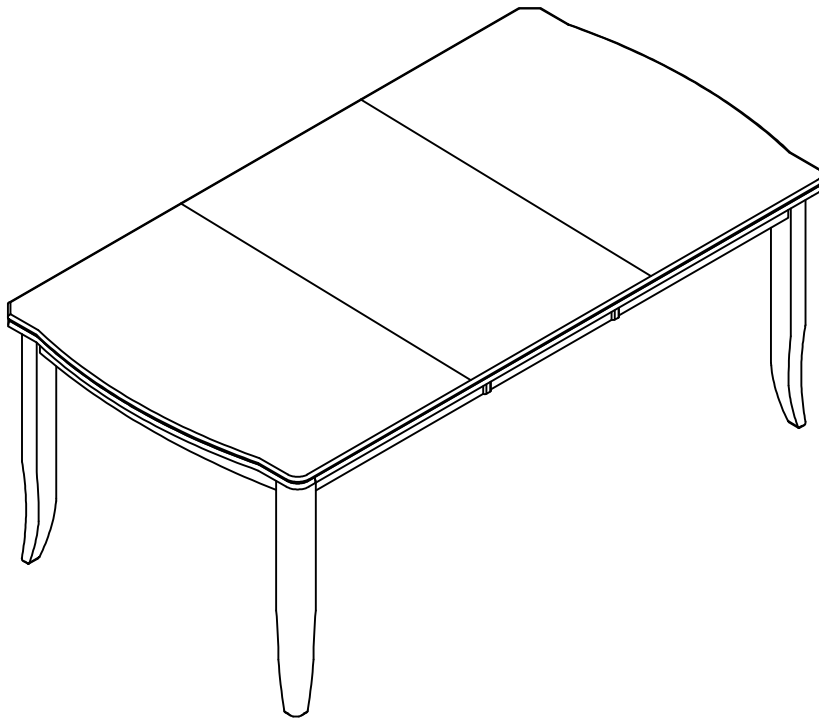

ASSEMBLY RATING

The Assembly Rating is a 5-point system that shows the degree of effort needed in assembling a specific product (with 1 being easy and 5 being difficult). For some products, two persons are recommended.

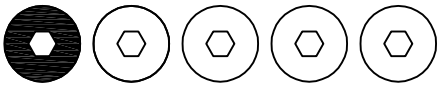
EASY  DIFFICULT

Tools Required For Assembly:

Wrench

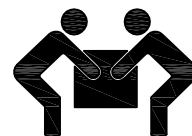

2 PERSONS RECOMMENDED

ASSEMBLY & CARE ADVICE

FOR YOUR FURNITURE TO LAST, CORRECT ASSEMBLY AND PROPER MAINTENANCE ARE NECESSARY. PLEASE FOLLOW THE INFORMATION PROVIDED BELOW TO FULLY ENJOY YOUR FURNITURE.

BASIC ASSEMBLY TECHNIQUES

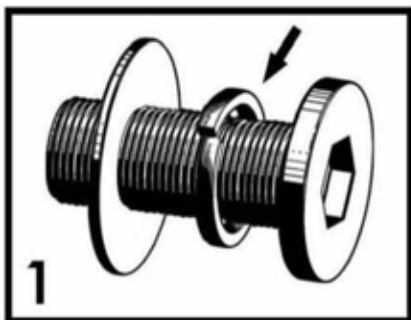

When lock or spring washer is used in an assembly, please make sure the lock or spring washer is placed between the larger flat washer and the head of the screw or bolt.



Position each part correctly and insert screws or bolts into their respective holes by hand tighten or using the proper hand tool. Only tighten when step is completed or when instructed to do so.

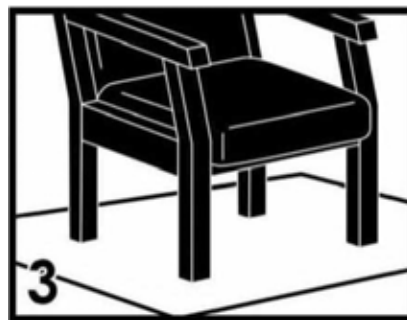

Use cardboard or carpet area when assembling furniture to prevent scratches. Make sure the furniture rests on a flat and level surface with each leg evenly touching the floor.

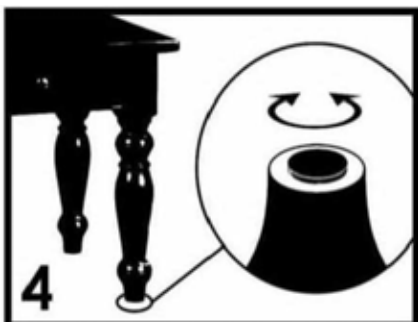

Some furniture comes with height adjustment knobs underneath each leg. To lower or to raise each leg, you need to turn clockwise or counterclockwise, respectively.

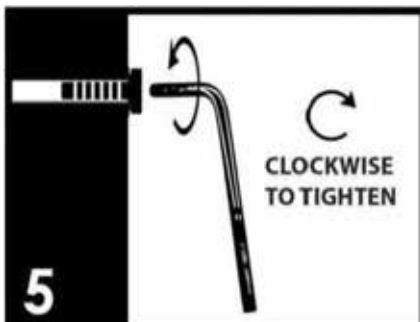

Make sure all parts are properly aligned, then use the appropriate hand tool to completely tighten the bolts or screws. Do not use power tools and do not overtighten.

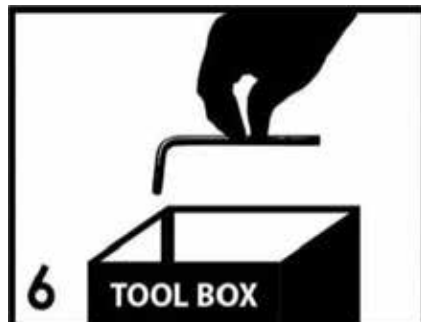

Save the instructions and store the Allen wrench or any supplied tool for later maintenance. After two weeks, check and tighten any loose hardware and repeat again every six months thereafter.

IT IS THE USER'S RESPONSIBILITY TO MAINTAIN THE FURNITURE. THE HARDWARE MAY LOOSEN OVER TIME AND MAY CAUSE THE FURNITURE TO BE WOBBLY AND UNABLE TO SUPPORT ITS INTENDED WEIGHT CAPACITY. THIS MAY LEAD TO COLLAPSE AND MAY CAUSE SERIOUS INJURY.

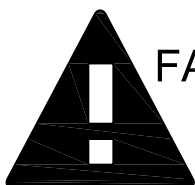

FAILURE TO FOLLOW THE GUIDELINES ABOVE MAY RESULT IN INJURY AND/OR PROPERTY DAMAGE.



Before you begin, please read Page 2 of "Assembly and Care Advice".

And remember, do not tighten until each step is completed or instructed.

Parts List

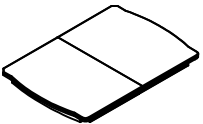

#1 x 1pc
Table Top

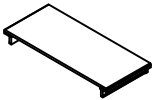

#2 x 1pc
Leaf

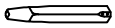

#3 x 4pcs
Leg

Hardware List



#A x 8pcs
Bolt 5/16"X2-1/2"



#B x 8pcs
Lock Washer



#Cx 8pcs
Flat Washer



#Dx 1pc
Wrench



#A x 8pcs
#B x 8pcs
#C x 8pcs

- I. With the help of another person, carefully place the table top (#1) facing down on a protected surface.
- II. Align the legs (#3) to the pre-drilled holes on the corners of the table top (#1).
- III. Prepare 8 bolt assemblies by FIRST inserting the lock washer (#B) onto the bolt (#A) then the flat washer (#C) onto that SAME bolt (#A). Insert into the corners and secure using the wrench (#D).

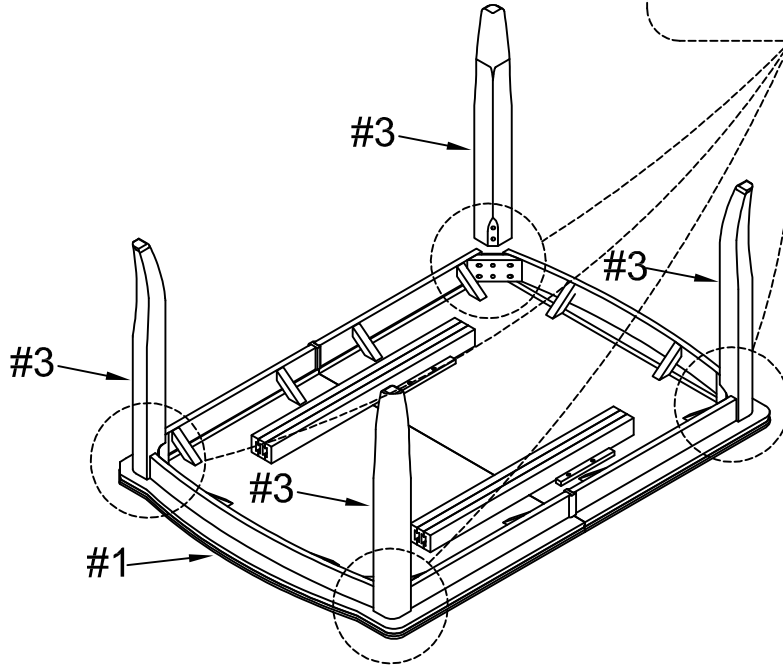
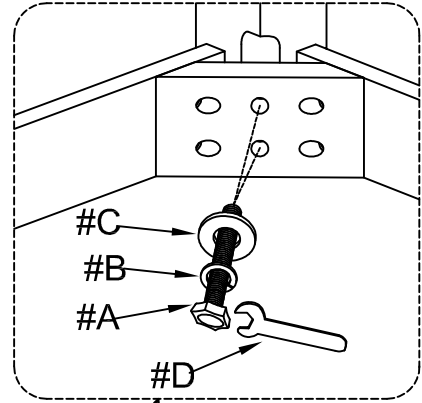

To insert the table leaf (#2) unlock the latches located under the table top (#1). Once unlocked, slide outward on both ends of the outer-piece table until there is sufficient opening to place the leaf (#2).

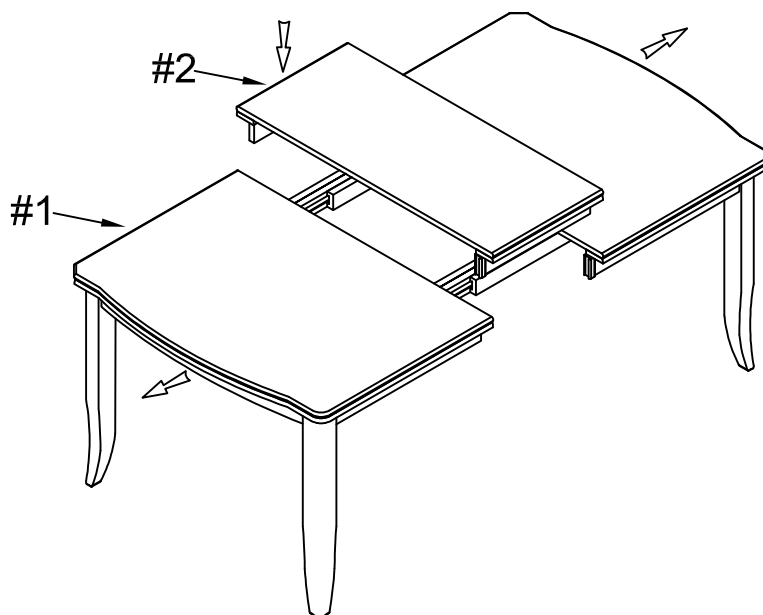



- I. Slide inward on both ends of the outer-piece table until they are touching and sitting flush with the table leaf (#2).
- II. Secure the parts together by locking the latches located under the table top (#1).

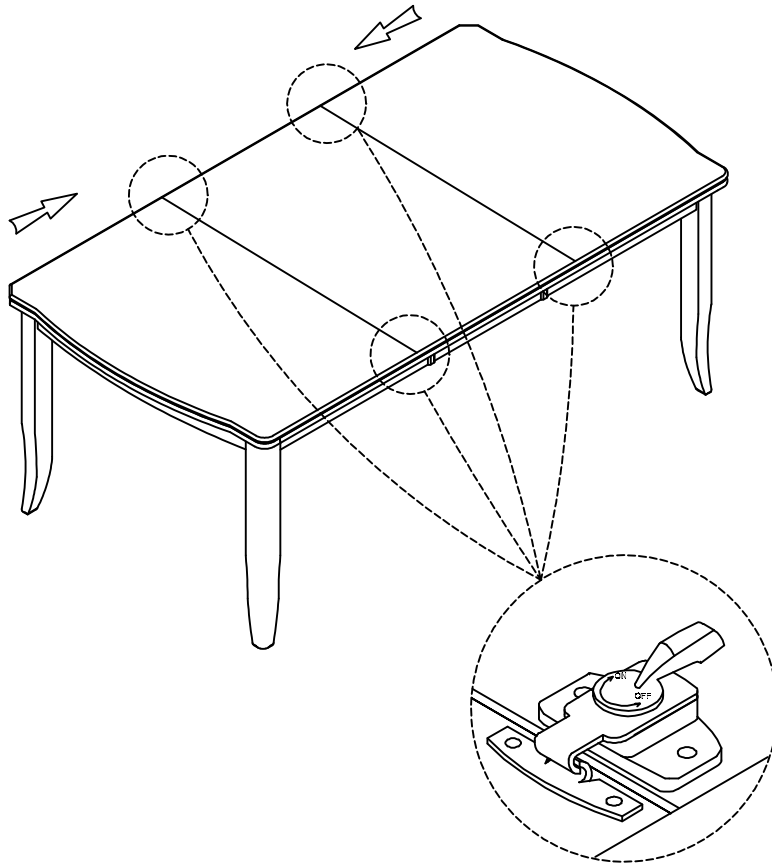

Carefully turn the completed table upright. Make sure the table is rested on a flat surface and does not feel loose or wobbly. If it does, double check that the bolts are secured and properly tightened.

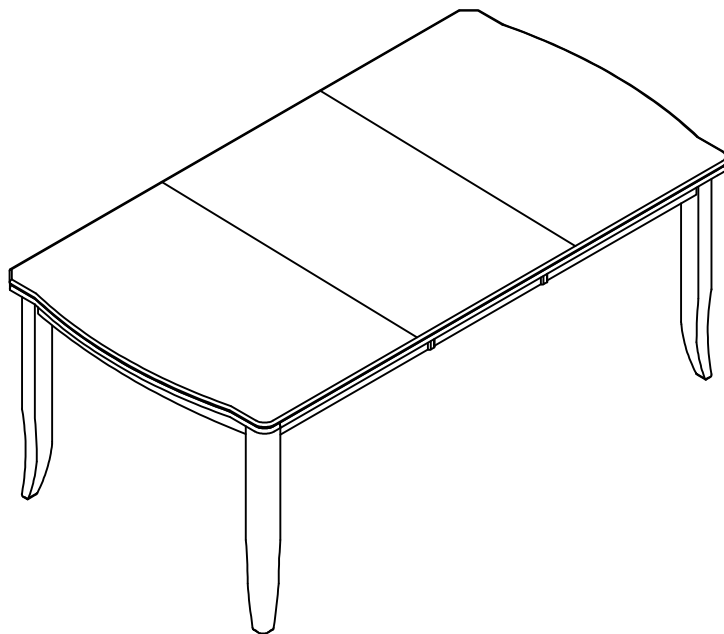

ASSEMBLY IS COMPLETED