

**Furniture of America**<sup>®</sup>

# Assembly Instructions

For more information contact our team: [service.ec@foagroup.com](mailto:service.ec@foagroup.com)

## CM3060SC-2PK

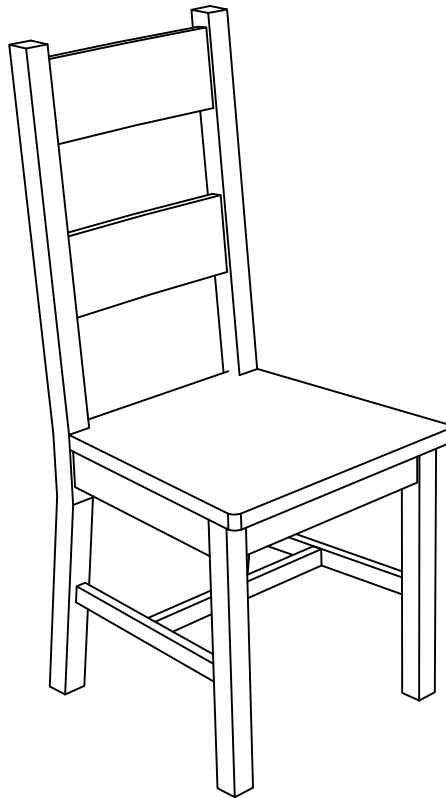

### ASSEMBLY RATING

The Assembly Rating is a 5-point system that shows the degree of effort needed in assembling a specific product (with 1 being easy and 5 being difficult). For some products, two persons are recommended.

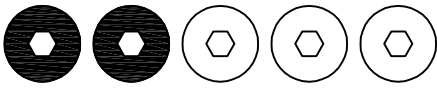
EASY  DIFFICULT

### Tools Required For Assembly:

Allen Wrench

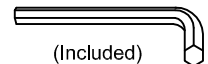

(Included)

Phillips Screwdriver

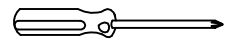

(Not Included)

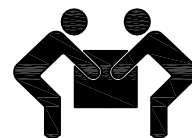

2 PERSONS RECOMMENDED

# ASSEMBLY & CARE ADVICE

FOR YOUR FURNITURE TO LAST, CORRECT ASSEMBLY AND PROPER MAINTENANCE ARE NECESSARY. PLEASE FOLLOW THE INFORMATION PROVIDED BELOW TO FULLY ENJOY YOUR FURNITURE.

## BASIC ASSEMBLY TECHNIQUES



When lock or spring washer is used in an assembly, please make sure the lock or spring washer is placed between the larger flat washer and the head of the screw or bolt.



Position each part correctly and insert screws or bolts into their respective holes by hand tighten or using the proper hand tool. Only tighten when step is completed or when instructed to do so.

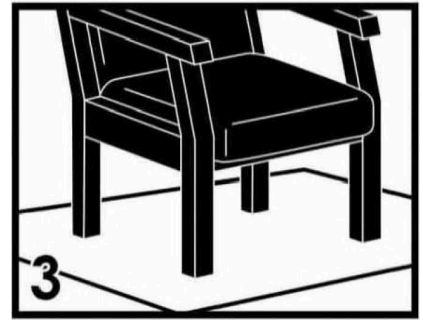

Use cardboard or carpet area when assembling furniture to prevent scratches. Make sure the furniture rests on a flat and level surface with each leg evenly touching the floor. No dragging of products/parts.



Some furniture comes with height adjustment knobs underneath each leg. To lower or to raise each leg, you need to turn clockwise or counterclockwise, respectively.

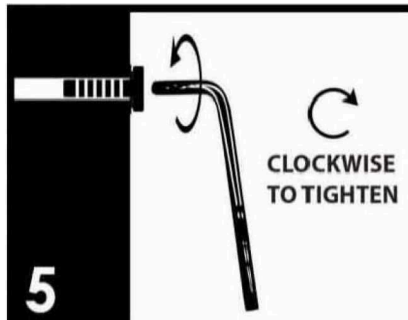

Make sure all parts are properly aligned, then use the appropriate hand tool to completely tighten the bolts or screws. Do not use power tools and do not overtighten.



Save the instructions and store the Allen wrench or any supplied tool for later maintenance. After two weeks, check and tighten any loose hardware and repeat again every six months thereafter.

IT IS THE USER'S RESPONSIBILITY TO MAINTAIN THE FURNITURE. THE HARDWARE MAY LOOSEN OVER TIME AND MAY CAUSE THE FURNITURE TO BE WOBBLY AND UNABLE TO SUPPORT ITS INTENDED WEIGHT CAPACITY. THIS MAY LEAD TO COLLAPSE AND MAY CAUSE SERIOUS INJURY.

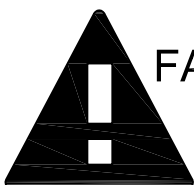

**FAILURE TO FOLLOW THE GUIDELINES ABOVE MAY RESULT IN INJURY AND/OR PROPERTY DAMAGE.**

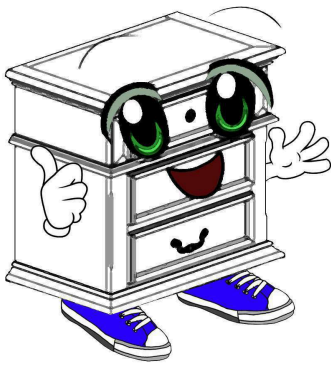

Before you begin, please read Page 2 of "Assembly and Care Advice".

And remember, do not tighten until each step is completed or instructed.

## Parts List

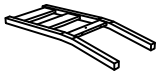

#1 x 1pc  
Chair Back Frame

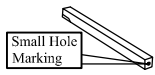

#2 x 1pc  
Right Front Leg



#3 x 1pc  
Left Front Leg



#4 x 1pc  
Right Side Stretcher



#5 x 1pc  
Left Side Stretcher

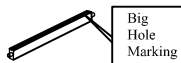

#6 x 1pc  
Middle Stretcher

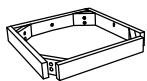

#7 x 1pc  
Box Seat

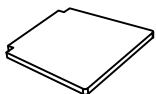

#8 x 1pc  
Wooden Seat

## Hardware List



#A x 6pcs  
Csk Screw M4 x 32mm



#B x 6pcs  
Csk Screw M4 x 35mm

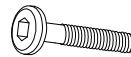

#C x 1pc  
Bolt 1/4" x 1-3/8"

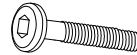

#D x 2pcs  
Bolt 1/4" x 2-3/8"

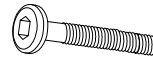

#E x 4pcs  
Bolt 1/4" x 2-3/4"



#F x 7pcs  
Lock Washer M6



#G x 7pcs  
Flat Washer M6 x 19MM



#H x 1pc  
Allen Wrench m4



#I x 1pc (extra)  
I-Key with ball m4



#C x 1pc  
 #E x 4pcs  
 #F x 5pcs  
 #G x 5pcs

DO NOT FULLY TIGHTEN ALL BOLTS UNTIL FULL ASSEMBLY OF PRODUCT IS COMPLETED.

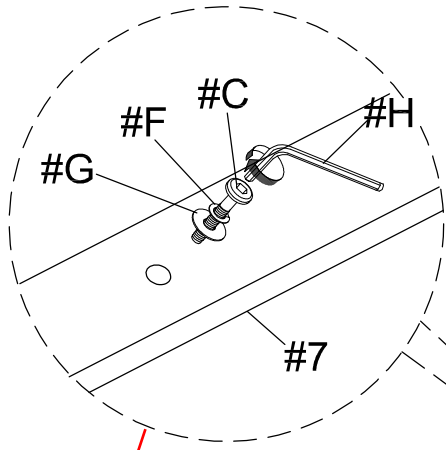

1) Align box seat (#7) to the chair back (#1). Secure middle hole of seat (#7) to chair back (#1) by using bolts (#C) with washers (#F,G).

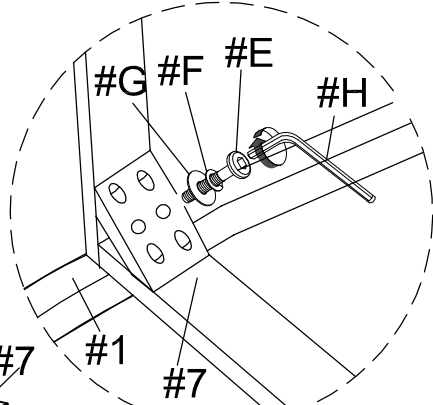

2) Secure corner holes of the seat (#7) to chair back (#1) by using bolts (#E) with washers (#F,G).

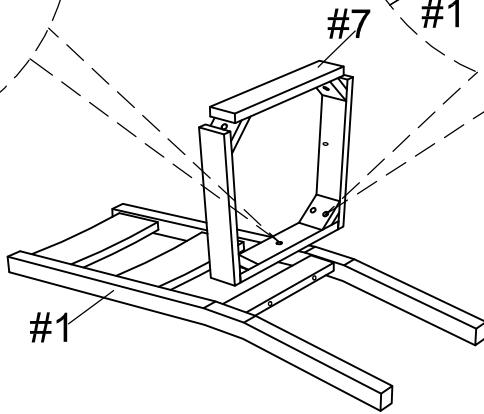

PLACE CHAIR ONTO A TABLE UPSIDE DOWN

#A x 3pcs  
 #D x 1pc  
 #F x 1pc  
 #G x 1pc

3) Align middle stretcher (#6) to the right side stretcher (#4), then secure by using screw (#A).

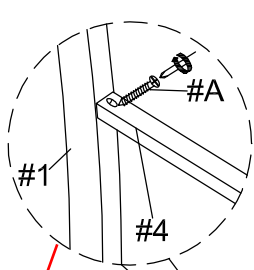

2) Align right side stretcher (#4) to the gaps of the chair legs, then secure by using screws (#A).

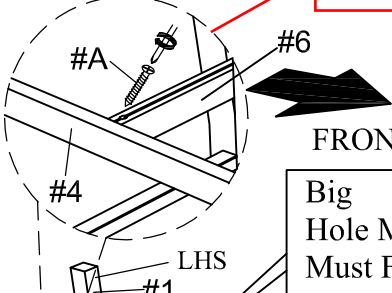

Big Hole Marking Must Facing Left

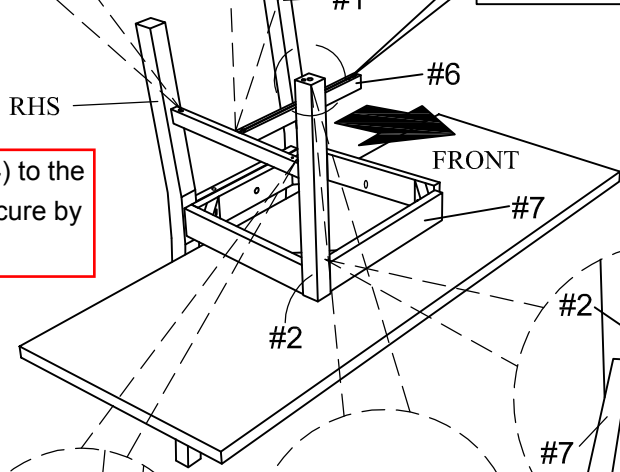

Small Hole Marking

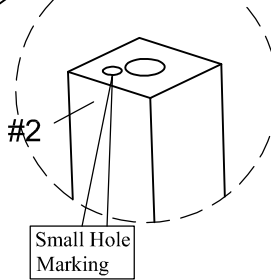
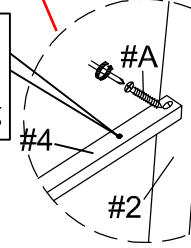

1) Align right front leg (#2) to the seat, then loosely secure by using bolts (#D) with washers (#F,G).



#3

3) Secure middle stretcher (#6) by using screws (#A).

Big Hole Marking  
Must Facing Left

2) Align left stretcher (#5) to the gaps of the legs and middle stretcher (#6).

3.3

3.2

3.4

Big Hole Marking

#A x 3pcs  
#D x 1pc  
#F x 1pc

4) Secure left stretcher (#5) to legs by using screws (#A).

1) Align front leg (#3) to the seat (#7), then loosely secure by using bolts (#D) with washers (#F,G).

3.1



#4

#B x 6pcs

Align wooden seat (#8) to the chair frame, then secure by using screws (#B).

#8

#7

#B

#B

#8

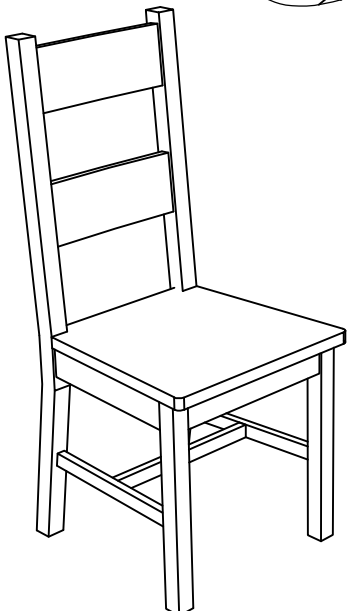

X2