



Furniture of America[®]

E-Commerce by Enitial Lab

ASSEMBLY INSTRUCTIONS

MODEL #

CM1028F

Questions?

GIVE US A CALL: 1-888-980-5122
MON – FRI 8:30AM – 5:30PM (PST)

TOOLS REQUIRED



Allen Wrench

(Included)



**Phillips
Screwdriver**

(Not Included)

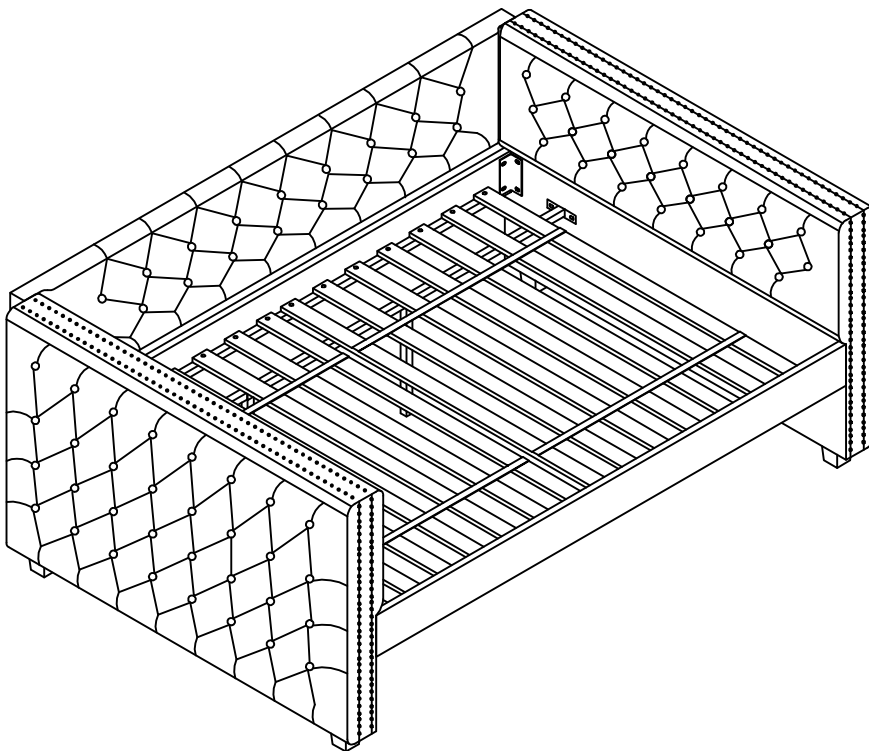

**3 - People
Recommended**

ASSEMBLY RATING



EASY —————> DIFFICULT

The Assembly Rating is a 5-point system showing the level of effort needed to assemble a specific product.



FOA Intro

Thank you for your purchase!

We hope you enjoy this new addition to your home for many years to come.

Our commitment to providing quality products does not simply end when you purchase our product. We fully stand behind our products from start to finish. Our customer service department is available Monday – Friday 8:30 AM – 5:30 PM Pacific and can help with assembly questions as well as, if necessary, replacing damaged or missing parts. To help expedite our service, please have these assembly instructions readily available, along with your order receipt.

 **Consumer Hotline**
Toll-Free 1-888-980-5122

 **WEBSITE**
www.foagroup.com

    foagroup

 **Monday to Friday**
8:30AM- 5:30PM (PST)

 **E-MAIL**
cs.ec@foagroup.com

 FurnitureOfAmerica

CHECK BEFORE STARTING

Are you missing anything?

Double-check all parts, hardware and accessories listed on Page 6 are accounted for.

Should we send any replacements?

Are there any irregularities or flaws in the parts? We can send replacements!

Check out our Quick Tips!

We recommend reviewing the pre-assembly handouts. Even experts need a refresher now and then!

Prep Time!

Please review the assembly instructions and all diagrams prior to assembling. Arrange parts as recommended on Page 7 and group identical hardware together to make assembling easier.

PRE ASSEMBLY INTRODUCTION

We understand building ready-to-assemble furniture can be a challenging experience for some. To help avoid confusion, we have provided some helpful tips that may speed up the process.

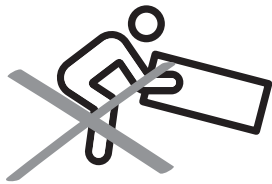

Teamwork

ALWAYS have at least two people to help with transporting and assembling the product to avoid potential injury and/or damage.



Suitable Location

Assembling near the area of the intended location is highly recommended.



Sufficient Space

Make sure you have enough space to move around during the assembly.



Avoid Scratches

Use cardboard, blankets or a carpeted area while assembling furniture to prevent scratches.



Flat Surface

Make sure the furniture rests on a flat and level surface with each leg evenly touching the floor.

ASSEMBLY AND CARE ADVICE



FAILURE TO FOLLOW THE GUIDELINES BELOW MAY RESULT IN INJURY AND/OR PROPERTY DAMAGE.



Position each part correctly and insert screws or bolts into their respective holes.



Use the appropriate hand tools or power tools for assembly. Select steps, such as tightening screws and/or bolts, may require hand tools to avoid causing damage during assembly.



Turn clockwise to tighten and only tighten when step is completed or when instructed to do so.



Save the instructions and store any supplied tools for later maintenance.



After two weeks, check and tighten any loose hardware and repeat again every six months thereafter.

IT IS THE USER'S RESPONSIBILITY TO MAINTAIN THE FURNITURE. THE HARDWARE MAY LOOSEN OVER TIME AND MAY CAUSE THE FURNITURE TO BE WOBBLY AND UNABLE TO SUPPORT ITS INTENDED WEIGHT CAPACITY. THIS MAY LEAD TO COLLAPSE AND MAY CAUSE SERIOUS INJURY.

BED

CM1028F



- Please keep instructions for future reference.
- Check the quantity and irregularity of parts and hardware before you start.

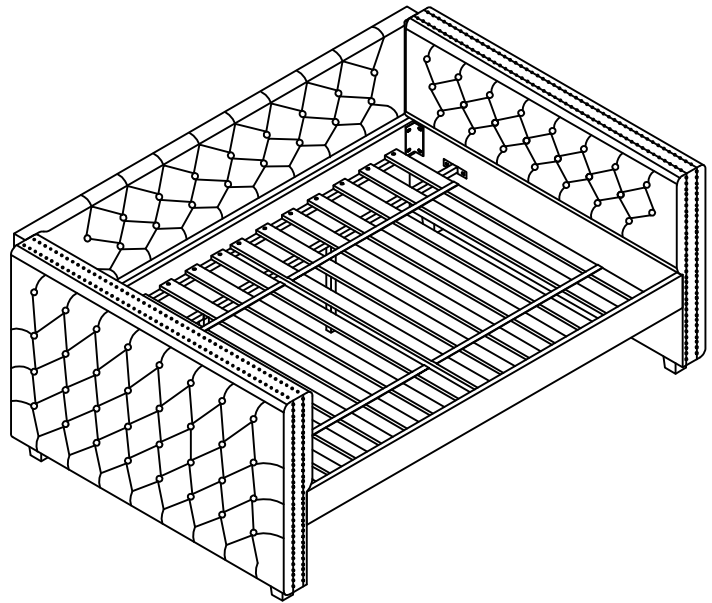

PARTS

#1 1pc

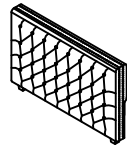

Left Arm

#2 1pc

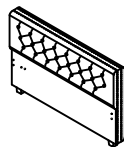

Right Arm

#3 1pc

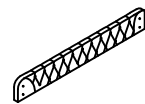

Back Rest

#4 2pcs



Slats For Daybed

#5 1pc



Back Rail

#6 1pc



Front Rail

#7 1pc



Middle Slat Panel

#8 1pc



Support Rail

#9 2pcs



support Leg
25*25*395MM

BED

CM1028F

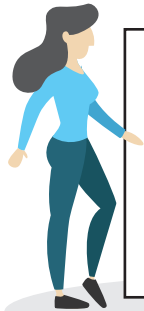

- Please keep instructions for future reference.
- Check the quantity and irregularity of parts and hardware before you start.

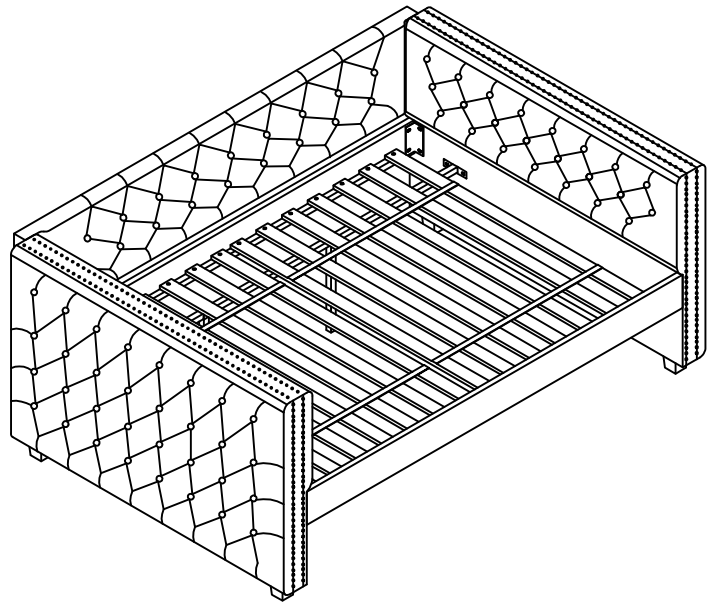

HARDWARE

#A 4pcs



90*45*3.0T mm

#B 1pc



Allen Wrench 5mm

#C 1pc



Allen Wrench 4mm

#D 20pcs



Lock Washer Ø5/16"

#E 20pcs



Flat Washer Ø5/16"

#F 6pcs



Flat Washer Ø 1/4

#G 4pcs



Bolt Ø5/16" x 2-1/2"

#H 8pcs



Bolt Ø5/16" x 1-1/2"

#I 8pcs



Bolt Ø5/16" x 1"

#J 6pcs







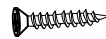





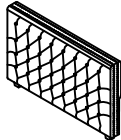
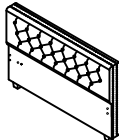
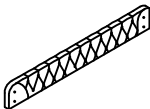
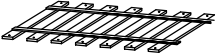



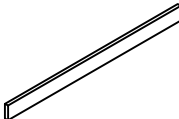

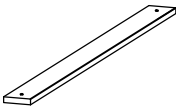
Bolt Ø1/4" x 1-3/4

#K 30pcs

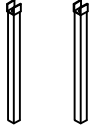

Screw M8x1-1/4"

CM1028F is packed in 2 cases

Carton	Disignation	Part		Hardware
CM1028F-1	Left Arm	#1		
	Right Arm	#2		
CM1028F-2	Back Rest	#3		
	Slats For Daybed	#4	 X 2	 #A x 4pcs
	Back Rail	#5		 #B x 1pc
	Front Rail	#6		 #C x 1pc
	Middle Slat Panel	#7		 #D x 20pcs
	Support Rail	#8		 #E x 20pcs
	Support Leg 25*25*395MM	#9		 #F x 6pcs
				 #G x 4pcs
			 #H x 8pcs	
			 #I x 8pcs	
			 #J x 6pcs	
			 #K x 30pcs	

ASSEMBLY INSTRUCTIONS

1

- Part **#1** x1pc
- Part **#2** x1pc
- Hardware **#A** x4pcs
- Hardware **#D** x16pcs
- Hardware **#E** x16pcs
- Hardware **#H** x 8pcs
- Hardware **#I** x 8pcs

Prepare 16 bolts assembly by inserting lock washer (#D), then flat washer (#E) onto bolts (#H,I). Align back/front rail (#5,6) to the end of the left/right arm (#1,2), then align bracket (#A) to the holes of the rails (#5,6) and arms (#1,2). Secure holes on the rails (#5,6) with bolts (#H) and secure holes on the arms (#1,2) with bolts (#I).

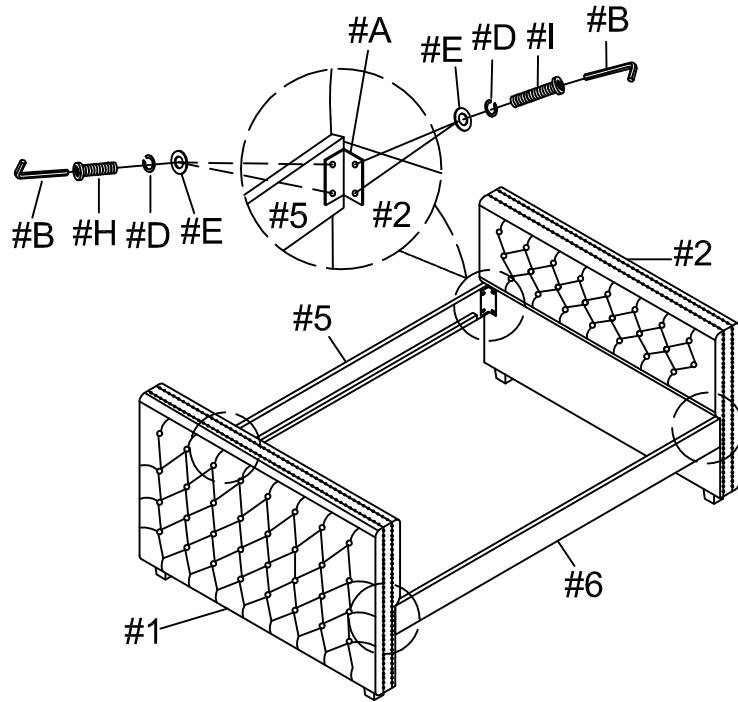

2

- Part **#8** x1pc
- Hardware **#F** x4pcs
- Hardware **#J** x4pcs

Prepare 4 bolts assembly by inserting washer (#F) onto bolts (#J). Align support rail (#8) to the holes of the arms (#1,2). Secure with bolts (#J).

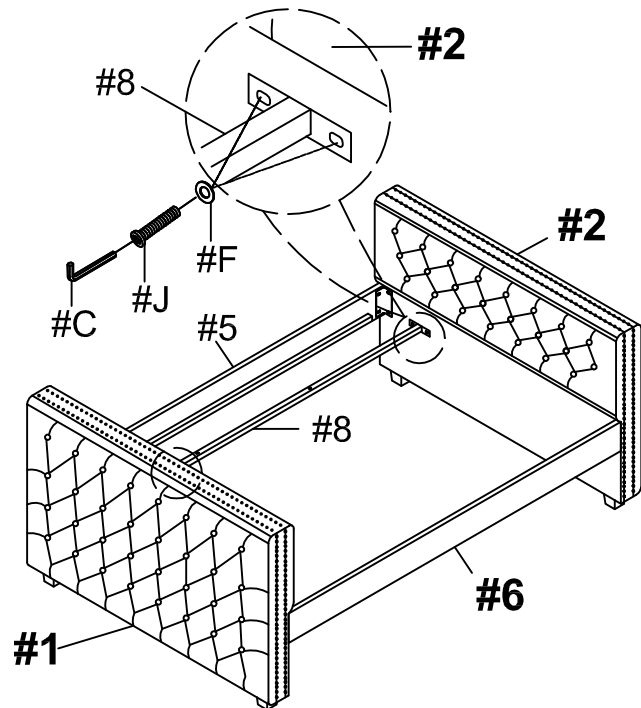

ASSEMBLY INSTRUCTIONS

3

- Part #9 x2pcs
- Hardware #F x2pcs
- Hardware #J x2pcs

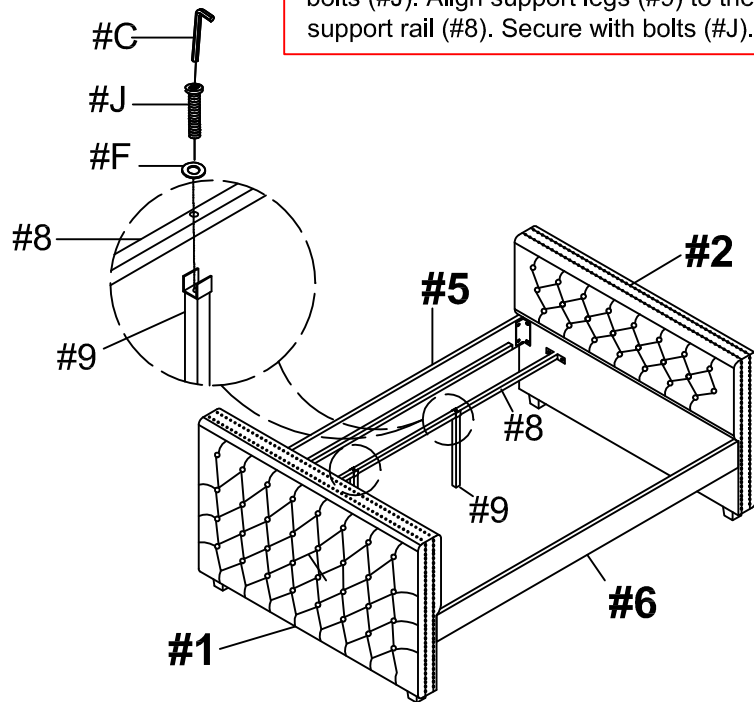

4

- Part #3 x1pc
- Hardware #G x4pcs
- Hardware #D x4pcs
- Hardware #E x4pcs

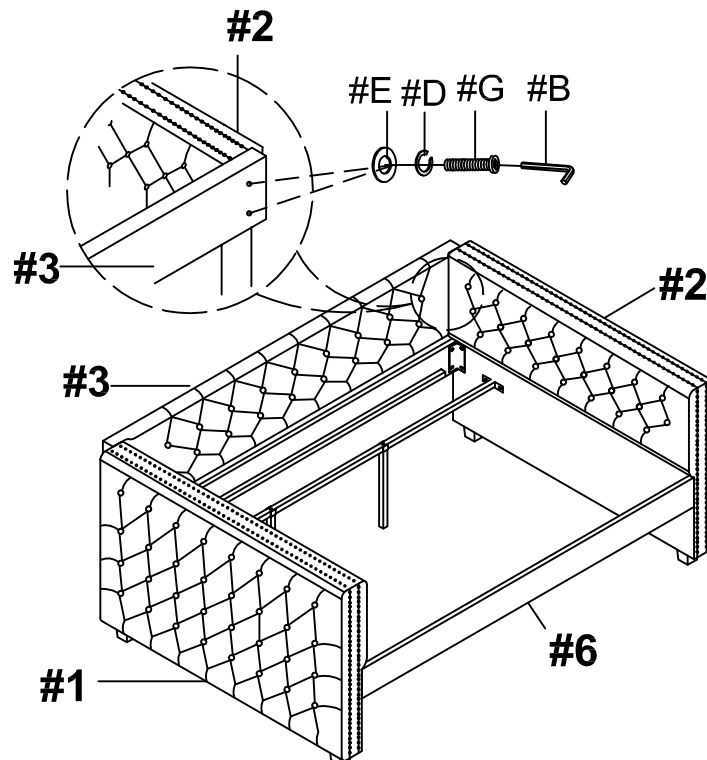

Prepare 4 bolts assembly by inserting lock washer (#D), then flat washer (#E) onto bolts (#G). Align back rest (#3) to the holes of the arms (#1,2). Secure with bolts (#G).

ASSEMBLY INSTRUCTIONS

5

Part #4 x2pcs
Hardware #K x30pcs

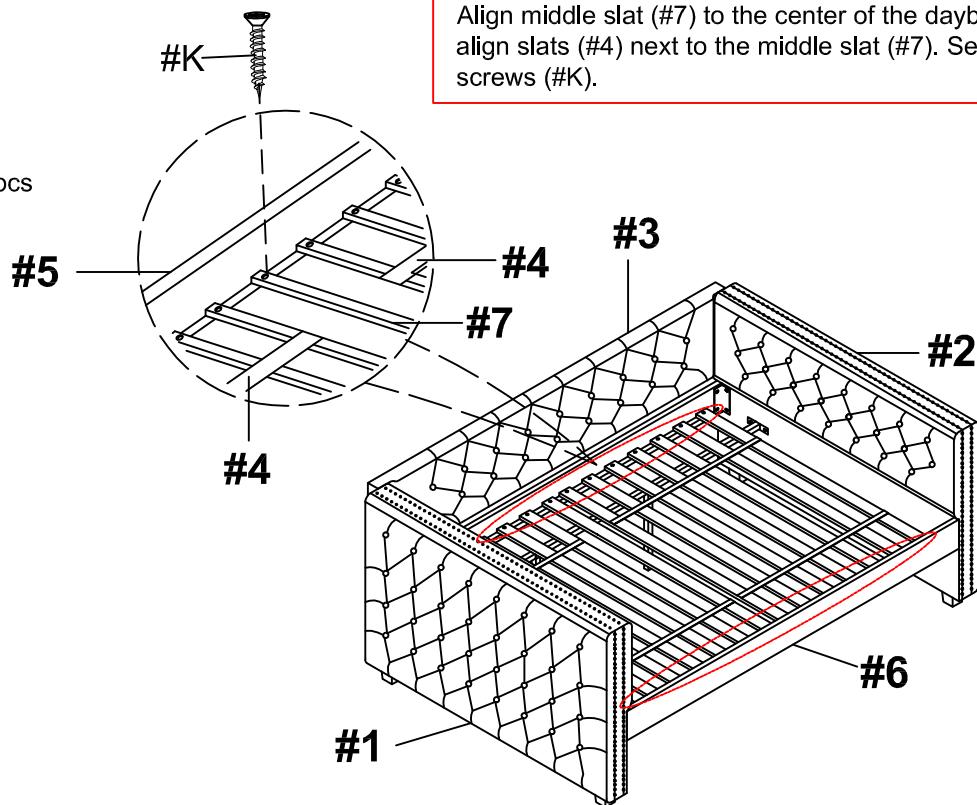

6

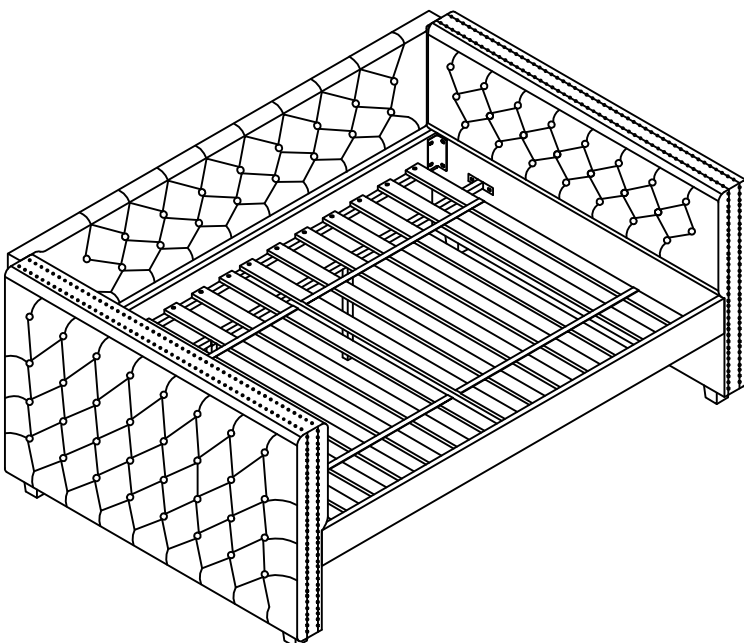

ASSEMBLY COMPLETED



Please ensure the furniture rests on an even and flat surface. If the product wobbles or feels loose, double-check all bolts and/or screws are properly tightened and secured.



Keep this handy!

Please retain this instruction manual and any order-related information for future reference.



Lift, don't drag!

To avoid damage to product please always LIFT the product when transporting or adjusting the placement.