

Furniture of America[®]

Assembly Instructions

For more information contact our team: service.ec@foagroup.com

CM-BK930-TQ

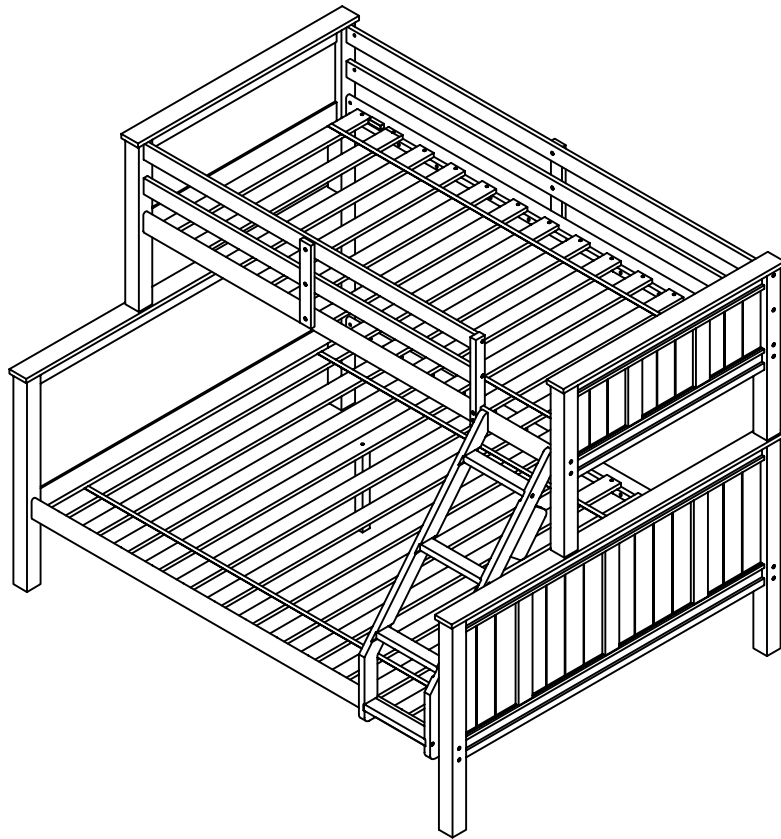

ASSEMBLY RATING

The Assembly Rating is a 5-point system that shows the degree of effort needed in assembling a specific product (with 1 being easy and 5 being difficult). For some products, two persons are recommended.

EASY



DIFFICULT

Tools Required For Assembly:

Allen Wrench

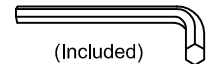

(Included)

Phillips Screwdriver



(Not Included)

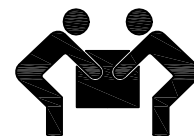

2 PERSONS RECOMMENDED

ASSEMBLY & CARE ADVICE

FOR YOUR FURNITURE TO LAST, CORRECT ASSEMBLY AND PROPER MAINTENANCE ARE NECESSARY. PLEASE FOLLOW THE INFORMATION PROVIDED BELOW TO FULLY ENJOY YOUR FURNITURE.

BASIC ASSEMBLY TECHNIQUES

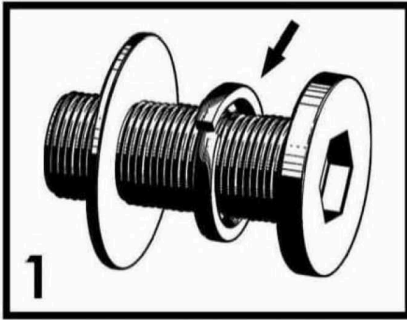

When lock or spring washer is used in an assembly, please make sure the lock or spring washer is placed between the larger flat washer and the head of the screw or bolt.

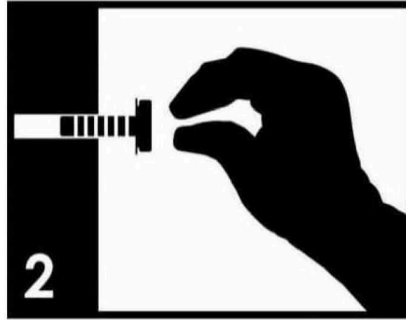

Position each part correctly and insert screws or bolts into their respective holes by hand tighten or using the proper hand tool. Only tighten when step is completed or when instructed to do so.

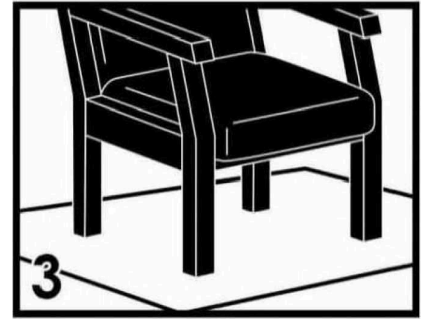

Use cardboard or carpet area when assembling furniture to prevent scratches. Make sure the furniture rests on a flat and level surface with each leg evenly touching the floor.

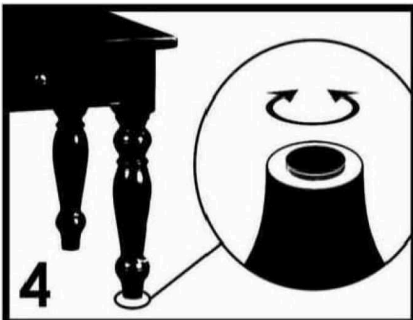

Some furniture comes with height adjustment knobs underneath each leg. To lower or to raise each leg, you need to turn clockwise or counterclockwise, respectively.

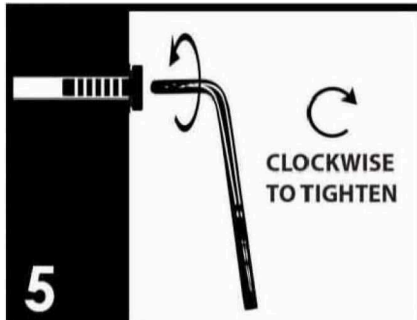

Make sure all parts are properly aligned, then use the appropriate hand tool to completely tighten the bolts or screws. Do not use power tools and do not overtighten.

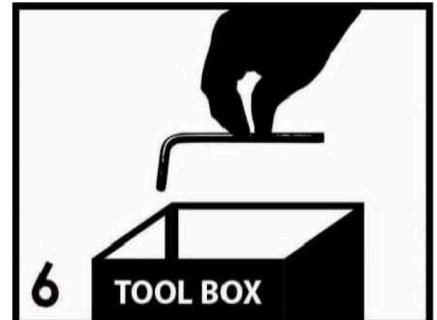

Save the instructions and store the Allen wrench or any supplied tool for later maintenance. After two weeks, check and tighten any loose hardware and repeat again every six months thereafter.

IT IS THE USER'S RESPONSIBILITY TO MAINTAIN THE FURNITURE. THE HARDWARE MAY LOOSEN OVER TIME AND MAY CAUSE THE FURNITURE TO BE WOBBLY AND UNABLE TO SUPPORT ITS INTENDED WEIGHT CAPACITY. THIS MAY LEAD TO COLLAPSE AND MAY CAUSE SERIOUS INJURY.

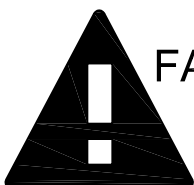

FAILURE TO FOLLOW THE GUIDELINES ABOVE MAY RESULT IN INJURY AND/OR PROPERTY DAMAGE.

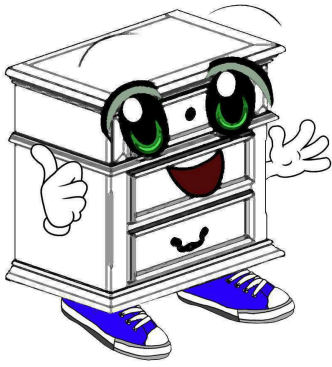

Before you begin, please read Page 2 of "Assembly and Care Advice".

And remember, do not tighten until each step is completed or instructed.

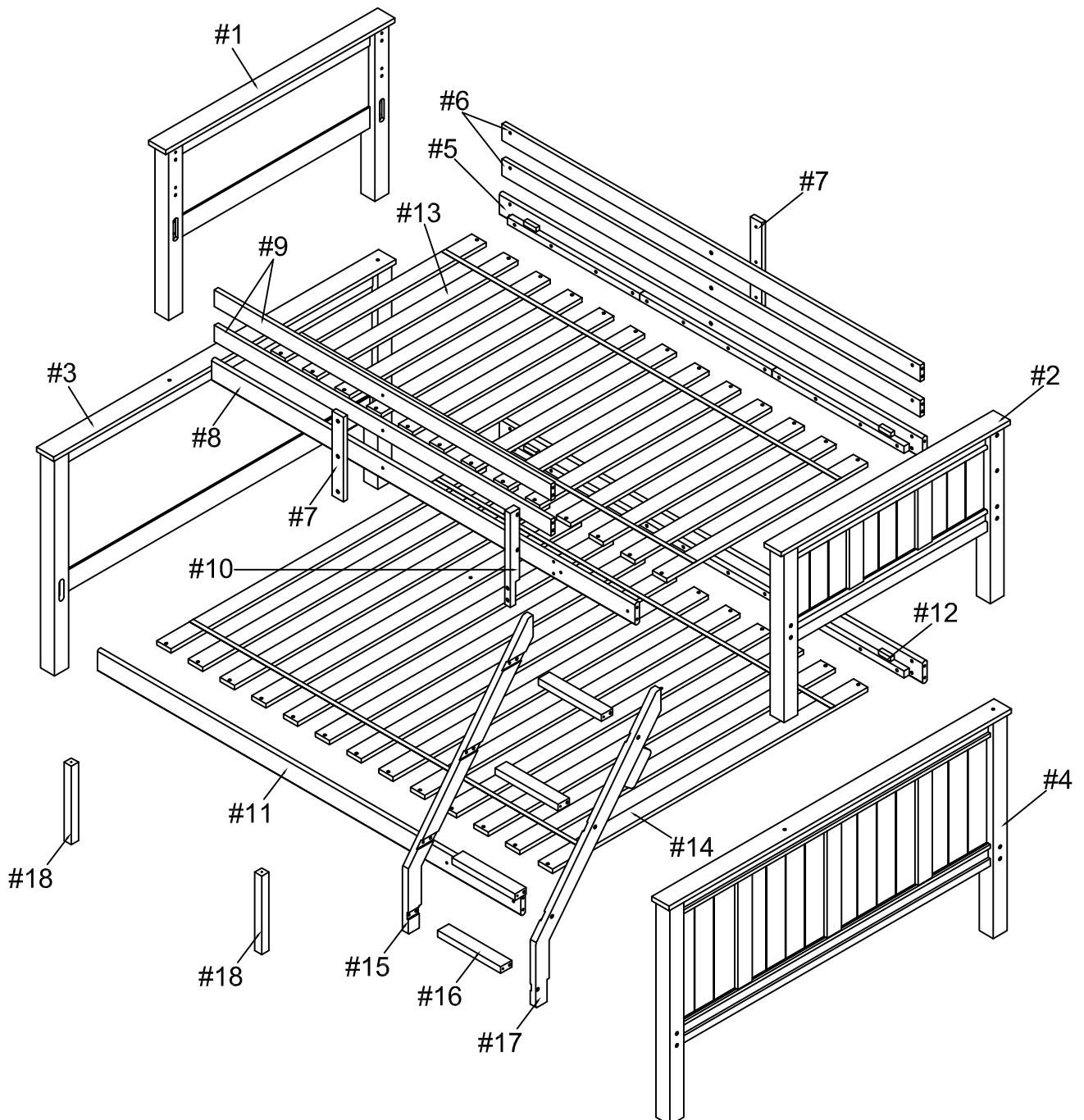

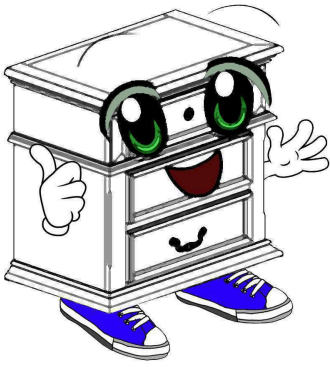



Before you begin, please read Page 2 of "Assembly and Care Advice".

And remember, do not tighten until each step is completed or instructed.

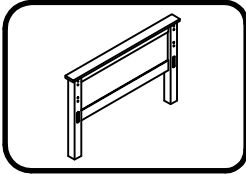
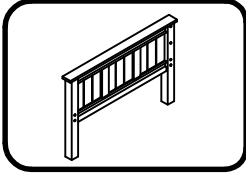
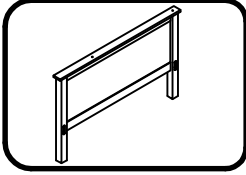
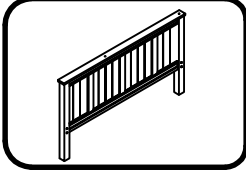
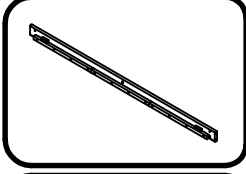
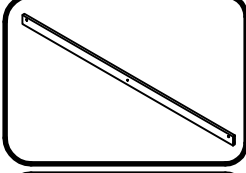
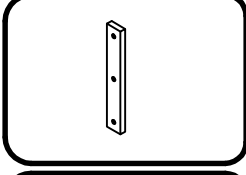
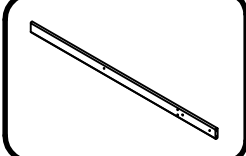
Parts List

- | | |
|--|--|
|  | #1 x 1pc
Upper Headboard |
|  | #2 x 1pc
Upper Footboard |
|  | #3 x 1pc
Lower Headboard |
|  | #4 x 1pc
Lower Footboard |
|  | #5 x 1pc
Upper Side Rail (Back) |
|  | #6 x 2pcs
Long Guard Rail |
|  | #7 x 2pcs
Vertical Guard Rail Support |
|  | #8 x 1pc
Upper Side Rail (Front) |

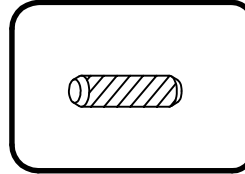
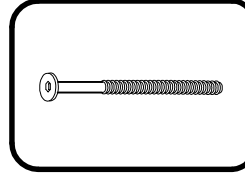
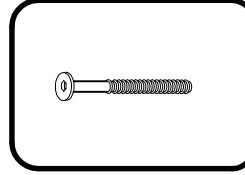
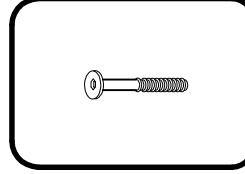
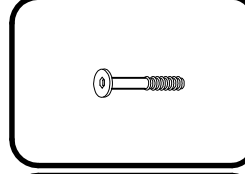
Hardware List

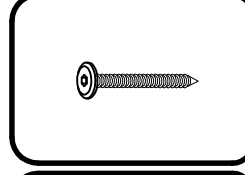
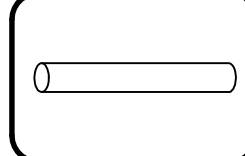
- | | |
|--|--|
|  | #A x 16pcs
Dowel Ø10 x 1-9/16" |
|  | #B x 22pcs
Long Bolt 1/4" x 4-3/4" |
|  | #C x 2pcs
Long Bolt 1/4" x 3-1/6" |
|  | #D x 6pcs
Short Bolt 1/4" x 1-9/16" |
|  | #E x 6pcs
Short Bolt 1/4" x 1-3/16" |
|  | #F x 24pcs
Barrel Nut 1/4" x 15 (9.5mm) |
|  | #G x 8pcs
Wood Screw 1/4"x2" |
|  | #H x 4pcs
Metal Pin Ø9x3-9/16" |

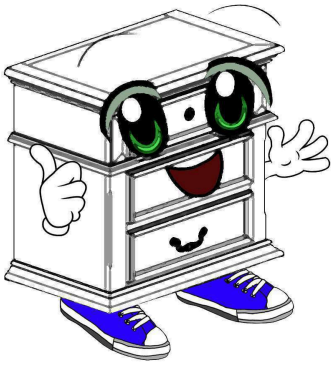

Before you begin, please read Page 2 of "Assembly and Care Advice".

And remember, do not tighten until each step is completed or instructed.

Parts List

Hardware List

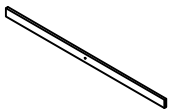

#9 x 2pcs
Short Guard Rail



#1 x 52pcs
Wood Screw Ø4 x 1-3/16"



#10 x 1pc
Front Guard Rail Support



#J x 2pcs
Wood Screw Ø4 x 1-3/4"

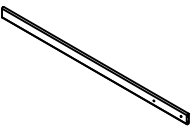

#11 x 1pc
Lower Side Rail (Front)



#K x 1pc
Allen Wrench M4



#12 x 1pc
Lower Side Rail (Back)

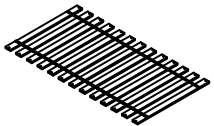

#13 x 1 set
Upper Slat (13pcs)

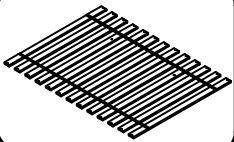

#14 x 1 set
Lower Slat (13pcs)

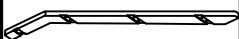

#15 x 1pc
Left Side Rail Ladder

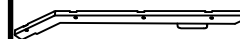

#17 x 1pc
Right Side Rail Ladder

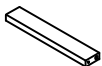

#16 x 4pcs
Step Ladder



#18 x 2pcs
Support



#1

#B x 8pcs
#F x 8pcs

1. Insert the barrel nuts (#F) into the holes along the sides of the lower side rails (#11,12). Align the openings to the holes.

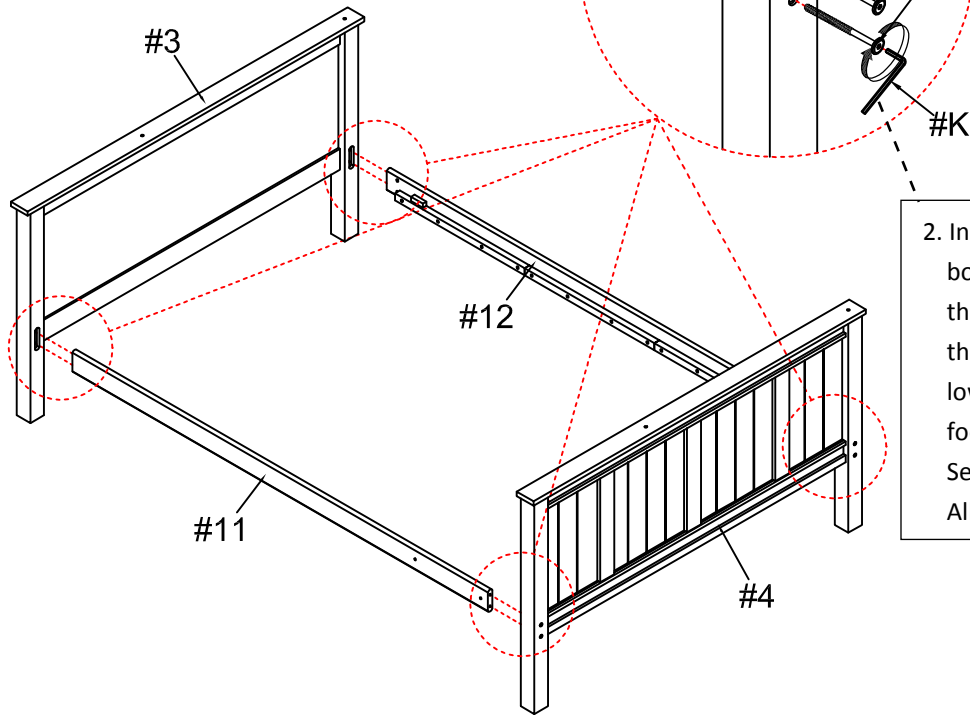

2. Insert the long bolts (#B) into the holes along the sides of the lower headboard/footboard (#3,4). Secure using the Allen wrench (#K).



#2

#A x 4pcs
#B x 12pcs
#F x 12pcs

1. Insert the dowels (#A) into the holes along the ends of the long guard rails (#6), insert the other ends into (#1) and (#2).

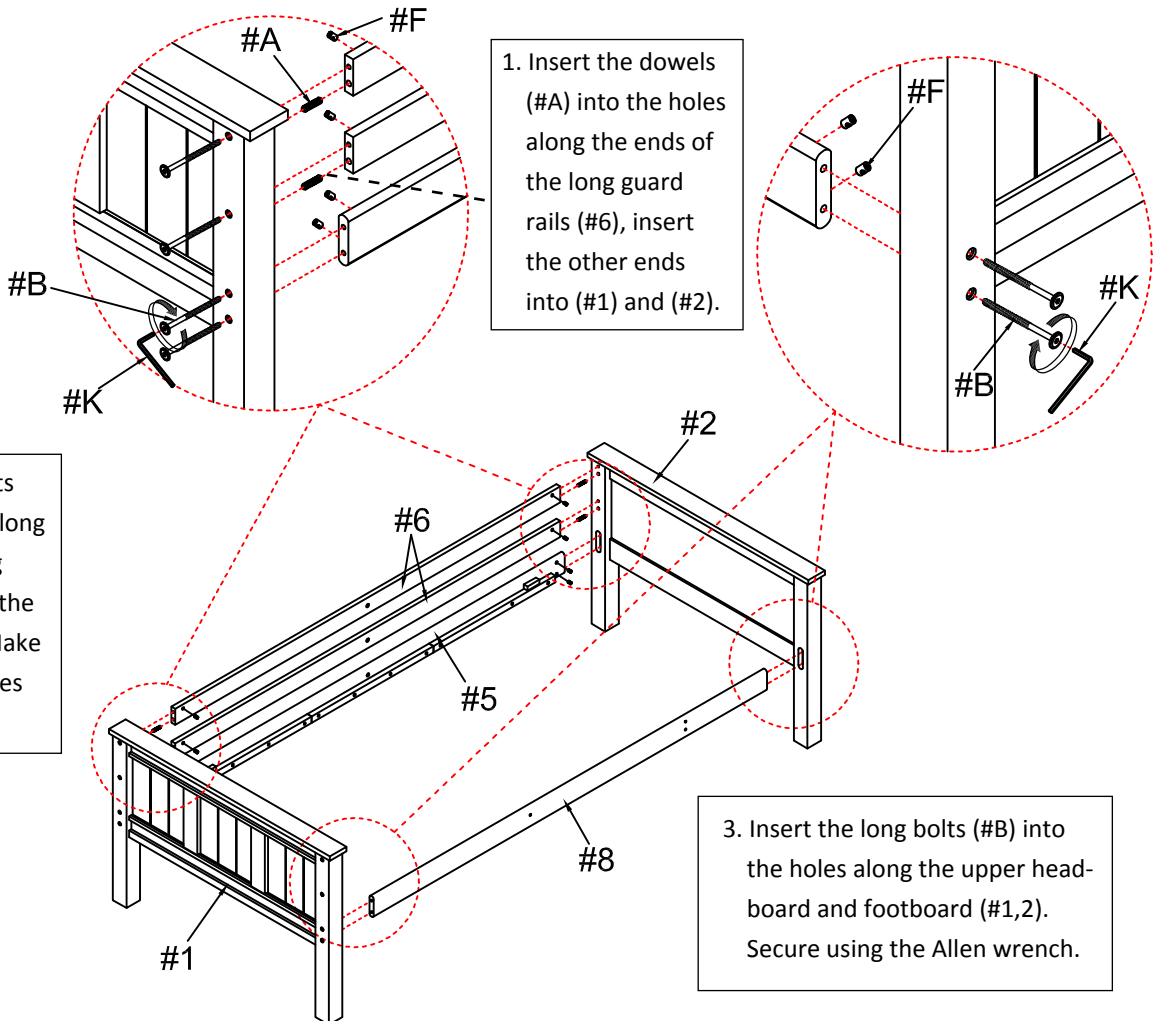

2. Insert the barrel nuts (#F) into the holes along the sides of the long guard rails (#6) and the upper rails (#5,8). Make sure to align the holes to the openings.

3. Insert the long bolts (#B) into the holes along the upper headboard and footboard (#1,2). Secure using the Allen wrench.



#3

Repeat process in step #2.

- #A x 4pcs
- #B x 2pcs
- #C x 2pcs
- #D x 2pcs
- #E x 6pcs
- #F x 4pcs

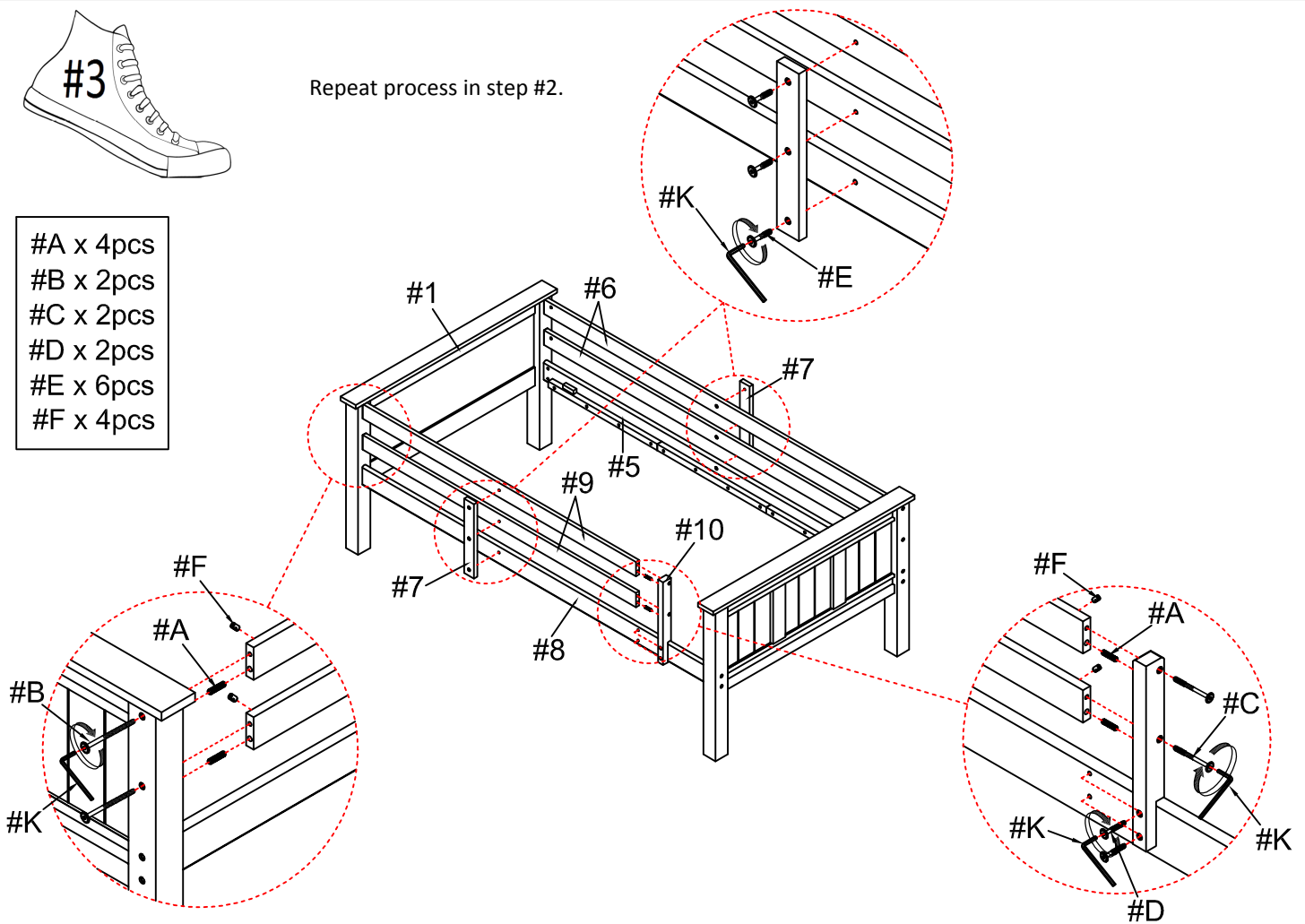

#4

- #H x 4pcs

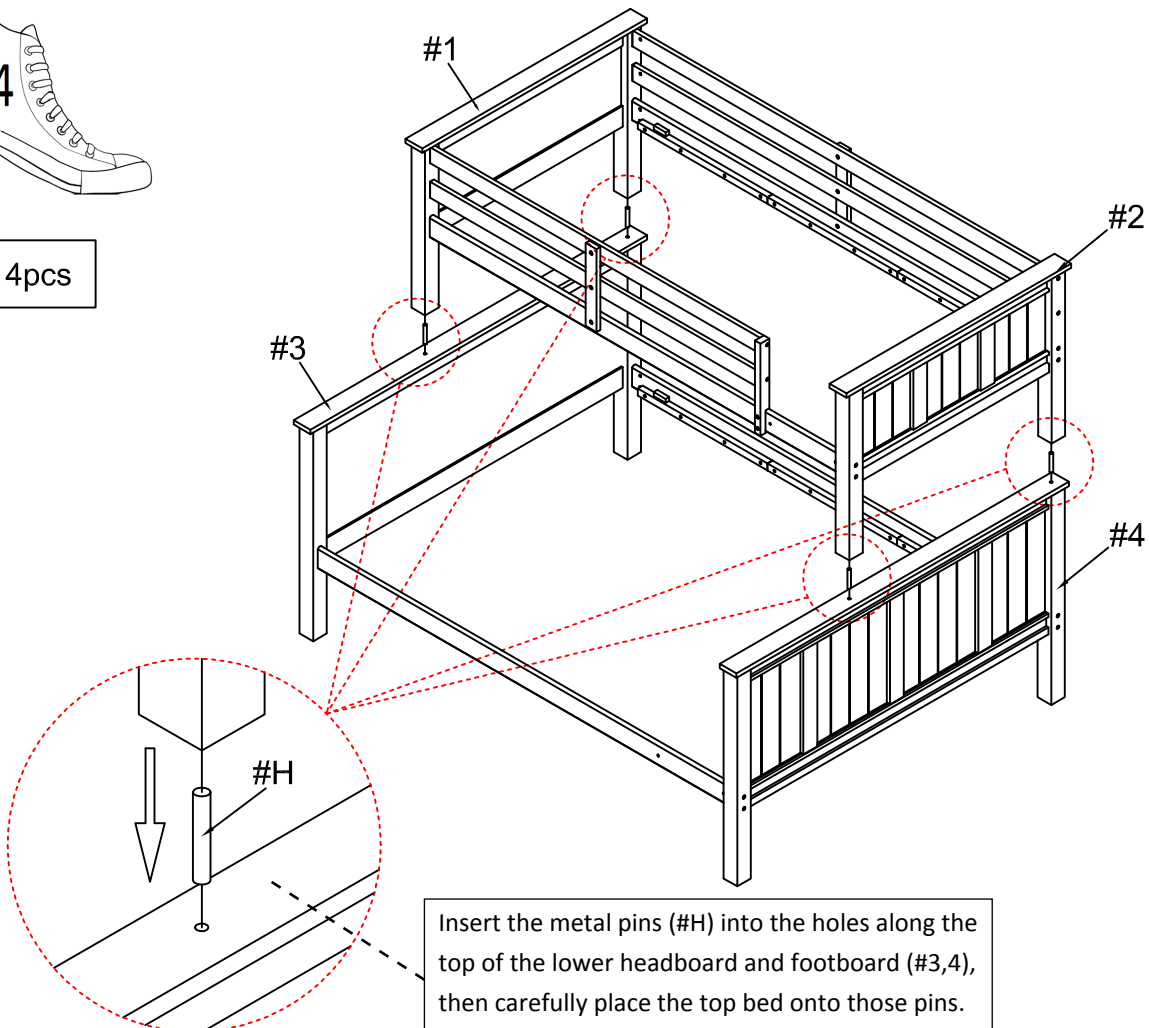



#5

#A x 8pcs
#G x 8pcs

Insert the dowels (#A) into each end of the steps (#16), then insert a bolt (#G) into each hole along the rails and secure using the Allen wrench (#K).

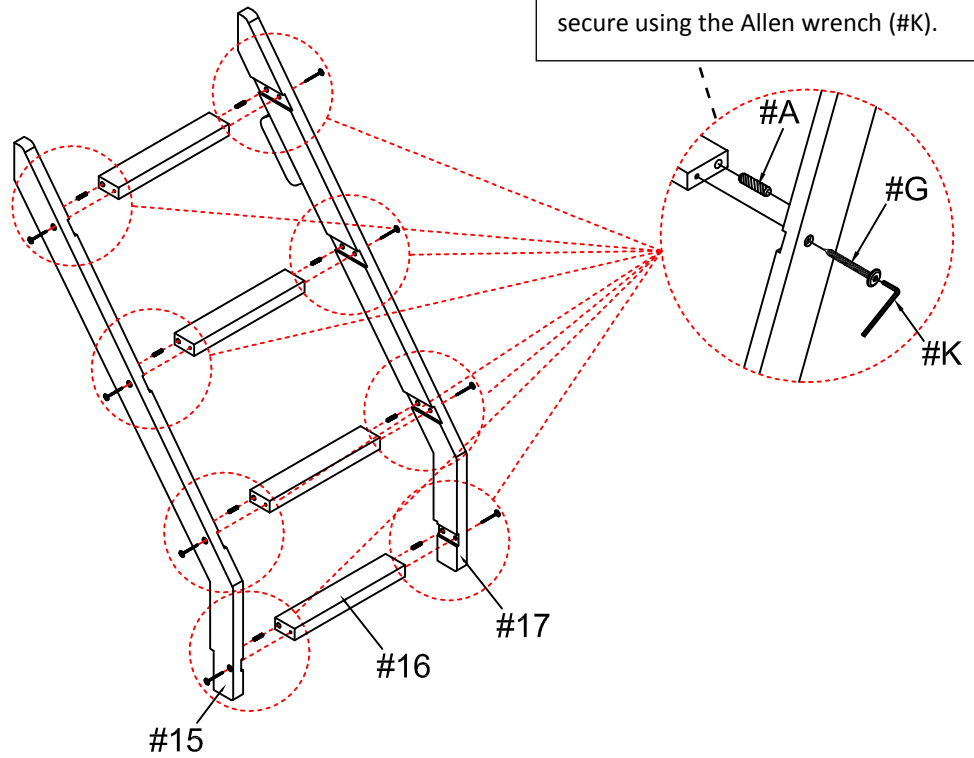

#6

#D x 4pcs

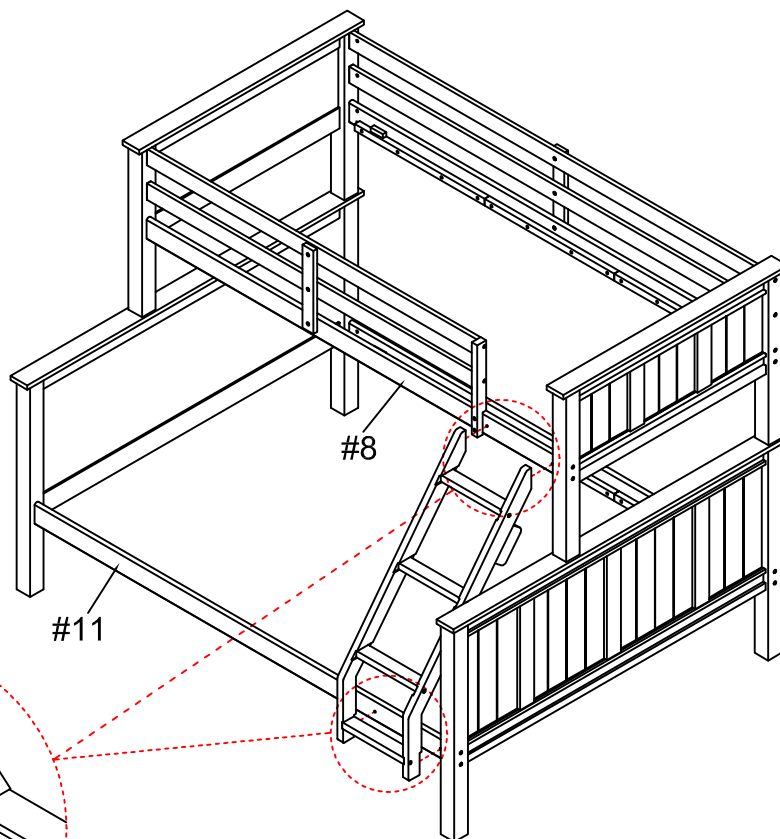

Align the top of the ladder rails to the holes, then insert a short bolt (#D) from within. Secure using the Allen wrench (#K).



#7

#I x 52pcs

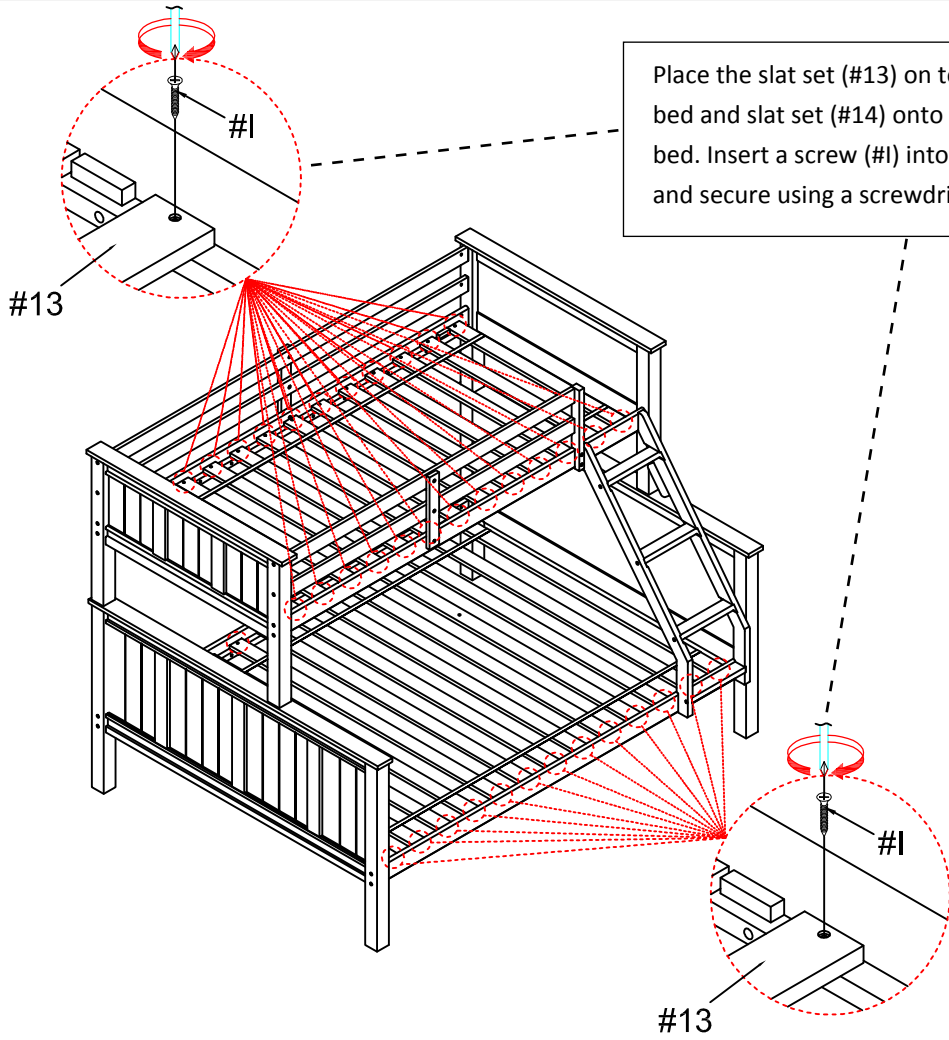

#8

#J x 2pcs

Align the support legs (#18) to the bottom slat set, then insert a screw (#J) into the holes and secure.

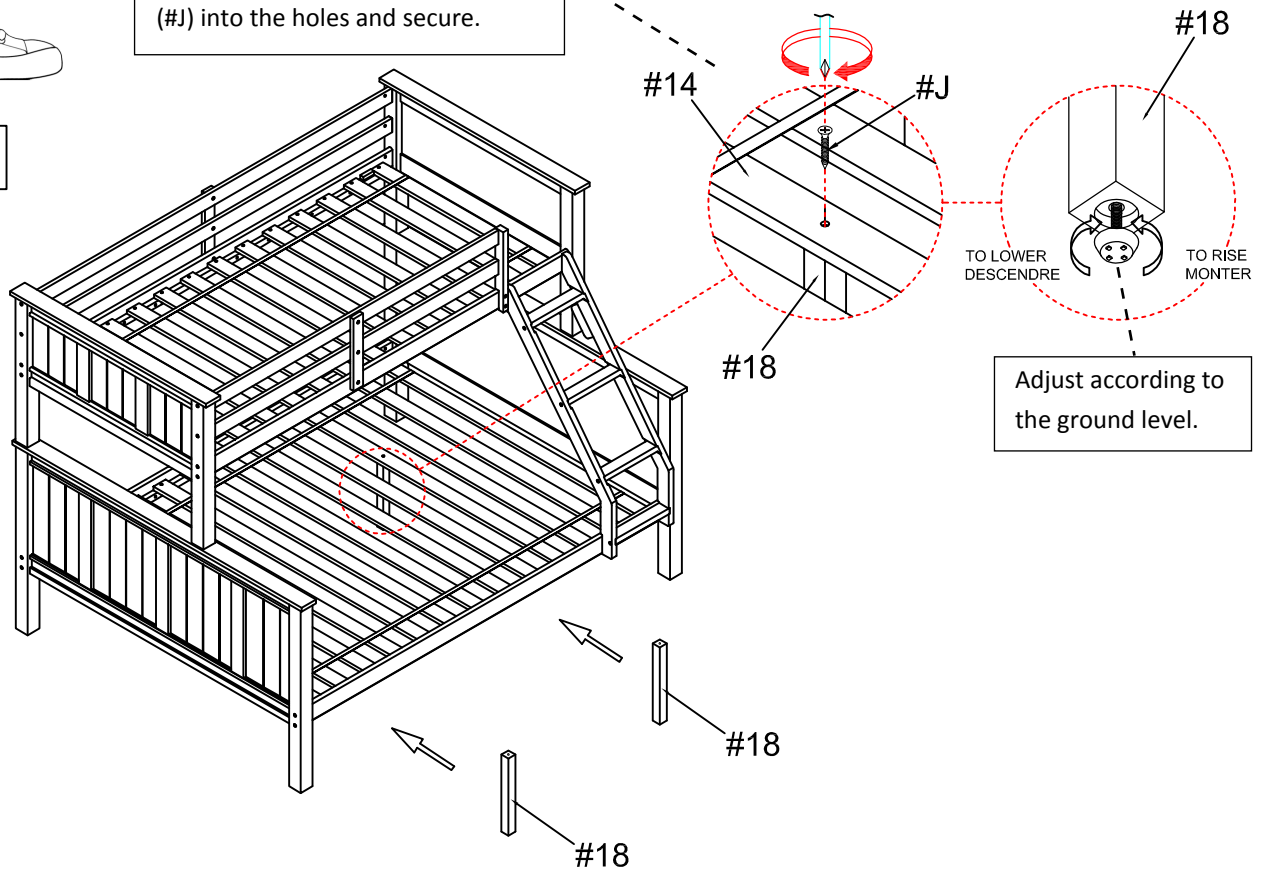

ASSEMBLY IS COMPLETED

Safety Warnings for Bunk Beds

1. Read and follow the information on the WARNINGS shown on the end structure of the upper bunk and on the carton.
2. Do not remove warning label from the bed.
3. Keep these instructions for future reference.
4. **IMPORTANT: Must use Bunkie mattress or Bunkie board.** The proper sizes for the **UPPER TWIN-SIZE** Bunkie mattress or bunkie board should be **80" - 81"** long and **37-1/2" - 38-1/2"** wide with no more than **6"** thickness and for the **LOWER QUEEN-SIZE** should be **80" - 81"** long and **60" - 61"** wide with no more than **6"** thickness.
5. Surface of mattress must be at least 5 inches (127mm) **BELOW** the upper edge of guardrails.
6. The **MAXIMUM** weight capacity for the upper bunk is not to exceed 175 lbs.
7. Do not allow children under 6 years of age to use the upper bunk.
8. Periodically check and ensure that the guardrails, ladder, handle and other components are in their proper position, free from damage, and that all connectors are tightened and secured.
9. **DO NOT** allow horseplay, rough playing or jumping on the beds and do not allow playing or hiding under the beds.
10. Always use the ladder for entering or leaving the upper bunk.
11. Do not use substitute parts. Contact the manufacturer or dealer for replacement parts.
12. Use of a nightlight may provide added safety precaution for a person using the upper bunk.
13. Always use the guardrails on both sides of the upper bunk.
14. If the bunk bed will be placed next to a wall, the guardrail that runs the full length of the bed should be placed against the wall to prevent entrapment between the bed and the wall.
15. The use of water or sleep flotation mattresses is prohibited.
16. No more than one person is allowed on the upper bunk at all times



WARNING: STRANGULATION HAZARD

Never attach or hang objects to any part of the bunk bed that are not designed for use with the bed. Objects such as hanger, hook, belt, bag, rope, string, etc. should not be used on or around the bunk bed.