

ASSEMBLY INSTRUCTIONS
COASTER FINE FURNITURE

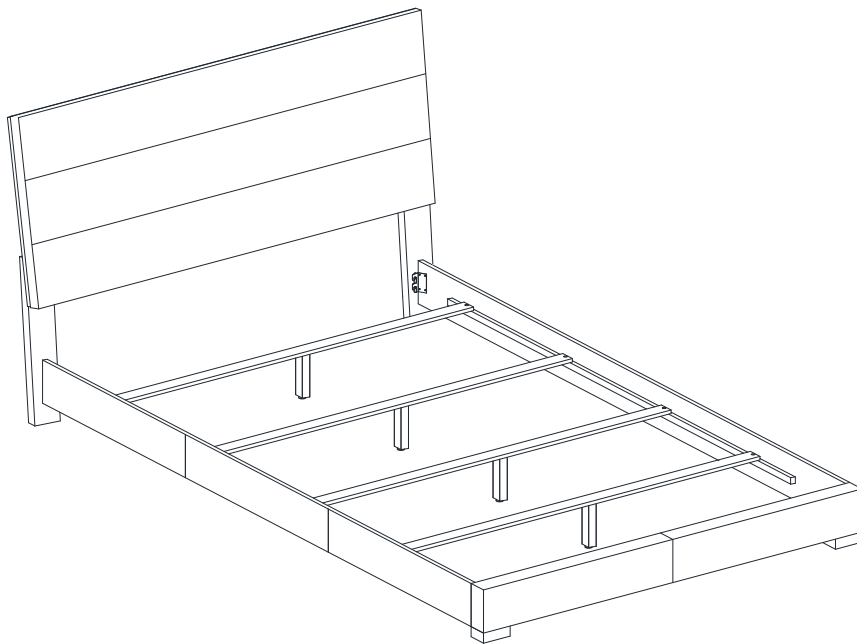

Fine Furniture for every stage of life

203501Q (B1&B2)
Queen Bed

REVISION 0 : 05/16/2014
REVISION 1 : 05/27/2014
REVISION 2 : 07/25/2019

ITEM: 203501Q (B1&B2)



ASSEMBLY INSTRUCTIONS

ASSEMBLY TIPS:

1. Remove hardware from box and sort by size.
2. Please check to see that all hardware and parts are present prior to start of assembly.
3. Please follow attached instructions in the same sequence as numbered to assure fast & easy assembly.

WARNING!



1. Don't attempt to repair or modify parts that are broken or defective. Please contact the store immediately.
2. This product is for home use only and not intended for commercial establishments.



ASSEMBLY TIME

30 MINUTES

PARTS IDENTIFICATION

B1 (BOX 1)

A HEADBOARD PANEL



1PC

B RIGHT HEADBOARD LEG



1PC

C LEFT HEADBOARD LEG

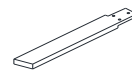

1PC

B2 (BOX 2)

D BED SLAT



4PCS

E BED SLAT SUPPORT WITH LEVELER



4PCS

F BED RAIL

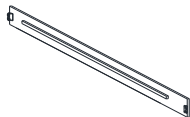

2PCS

G FOOTBOARD LEG

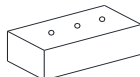

2PCS

H FOOTBOARD PANEL

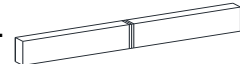

1PC

HB
203501Q (B1)
FROM BOX 1
HEADBOARD
COMPLETE

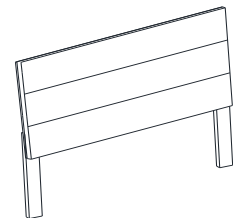

1PC

NOTE:

Phillips head screw driver is required in the assembly process; however, manufacturer does not provide this item.

ITEM: 203501Q (B1&B2)



ASSEMBLY INSTRUCTIONS

ASSEMBLY TIPS:

1. Remove hardware from box and sort by size.
2. Please check to see that all hardware and parts are present prior to start of assembly.
3. Please follow attached instructions in the same sequence as numbered to assure fast & easy assembly.



WARNING!

1. Don't attempt to repair or modify parts that are broken or defective. Please contact the store immediately.
2. This product is for home use only and not intended for commercial establishments.

HARDWARE IDENTIFICATION

Z-B1 (BOX 1) - HARDWARE PACK IS LOCATED IN 203501Q (B1)

1 **BOLT**
(M6 x 30mm - BLK)  6PCS

2 **SMALL ALLEN WRENCH**
(M4 x 60MM - BLK)  1PC

3 **FLAT WASHER**
(1/4" X 13mm - BLK)  6PCS

4 **LOCK WASHER**
(1/4" - BLK)  6PCS

Z-B2 (BOX 2) - HARDWARE PACK IS LOCATED IN 203501Q (B2)

5 **SHORT FLAT HEAD SCREW**
(M4 x 32mm - RBW)  8PCS

6 **LONG FLAT HEAD SCREW**
(M4 x 50mm - RBW)  6PCS

7 **BOLT**
(M6 x 40mm - BLK)  4PCS

8 **SMALL ALLEN WRENCH**
(M4 x 60MM - BLK)  1PC

9 **BIG ALLEN WRENCH**
(M5 x 65MM - BLK)  1PC

NOTE:

Phillips head screw driver is required in the assembly process; however, manufacturer does not provide this item.

ITEM: 203501Q (B1&B2)

ASSEMBLY INSTRUCTIONS

STEP 1

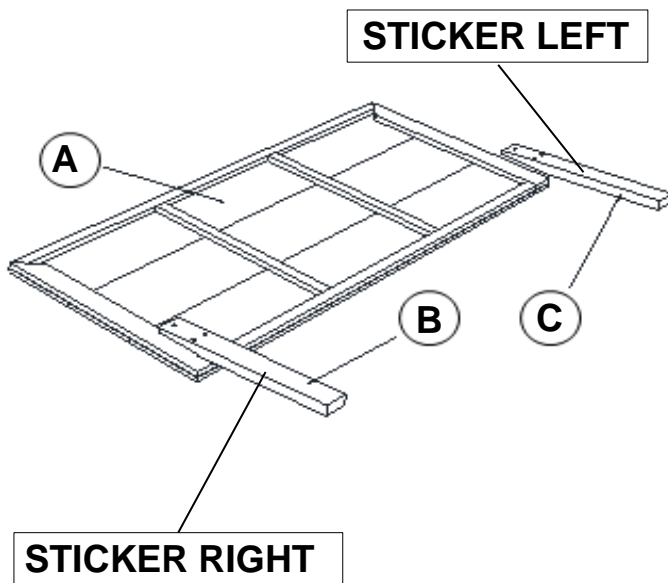

STEP 2

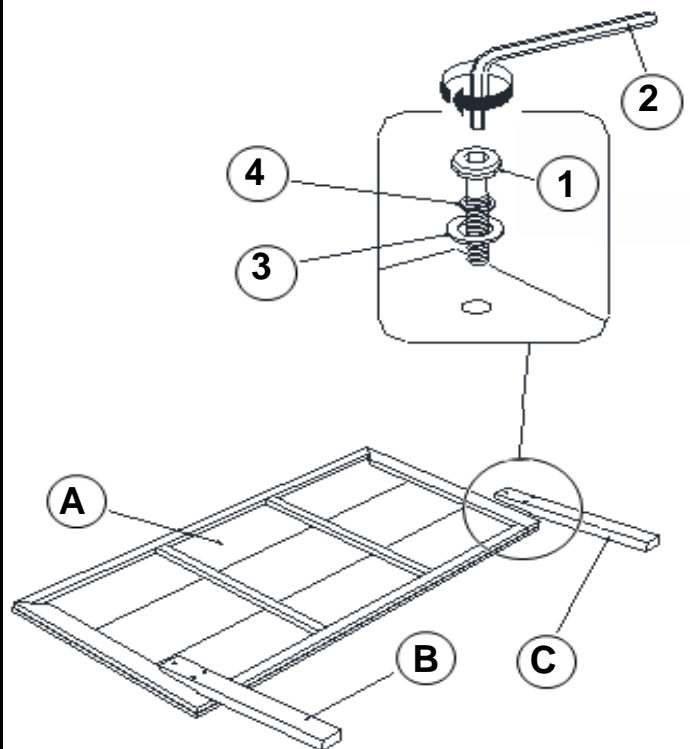

IF PURCHASE HEADBOARD ONLY, SKIP BELOW STEPS

STEP 3

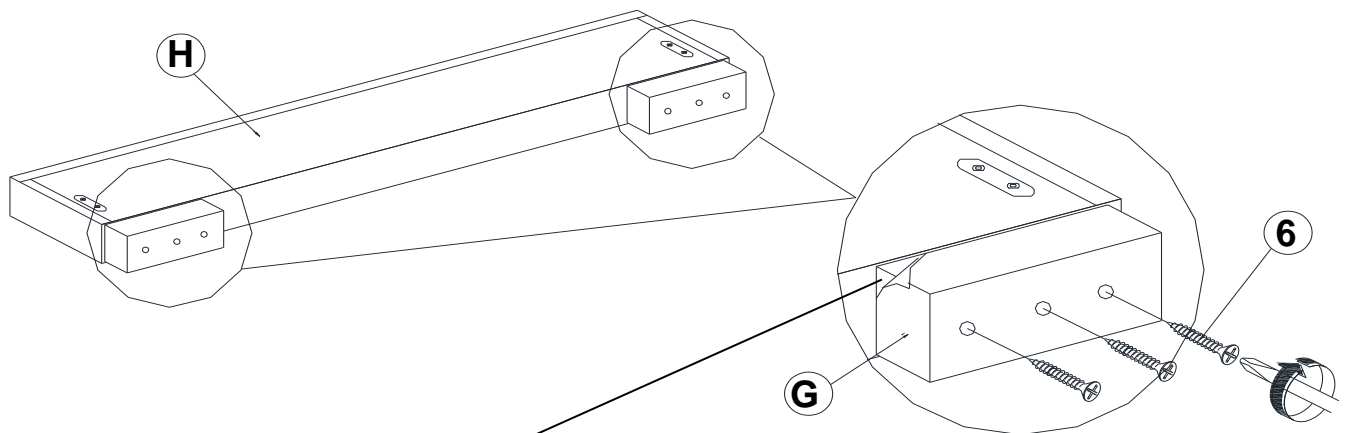

PLEASE REMOVE THE PROTECTIVE FILM BEFORE ASSEMBLY

ITEM: 203501Q (B1&B2)

ASSEMBLY INSTRUCTIONS

STEP 4

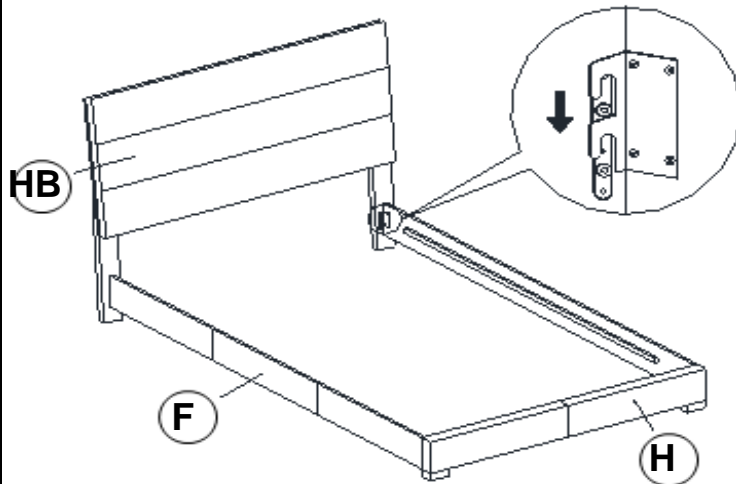

STEP 5

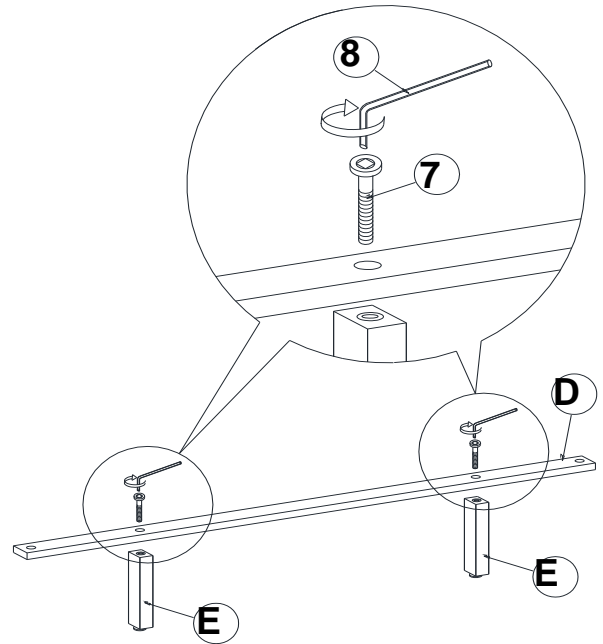

STEP 6

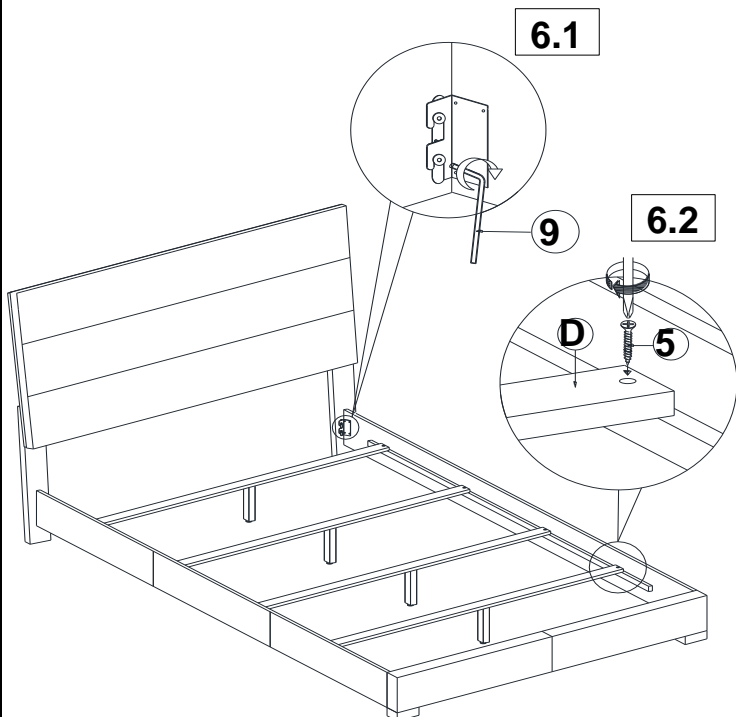

STEP 7 COMPLETE

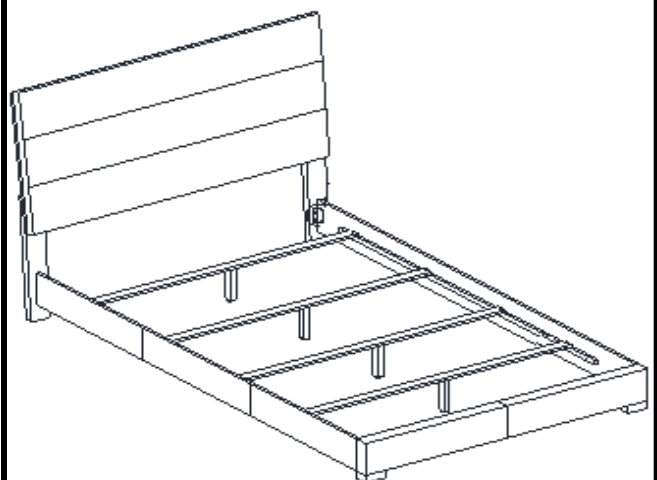

ITEM: 203501Q (B1&B2)



Inner Size : 60.75"W X 80.25"D

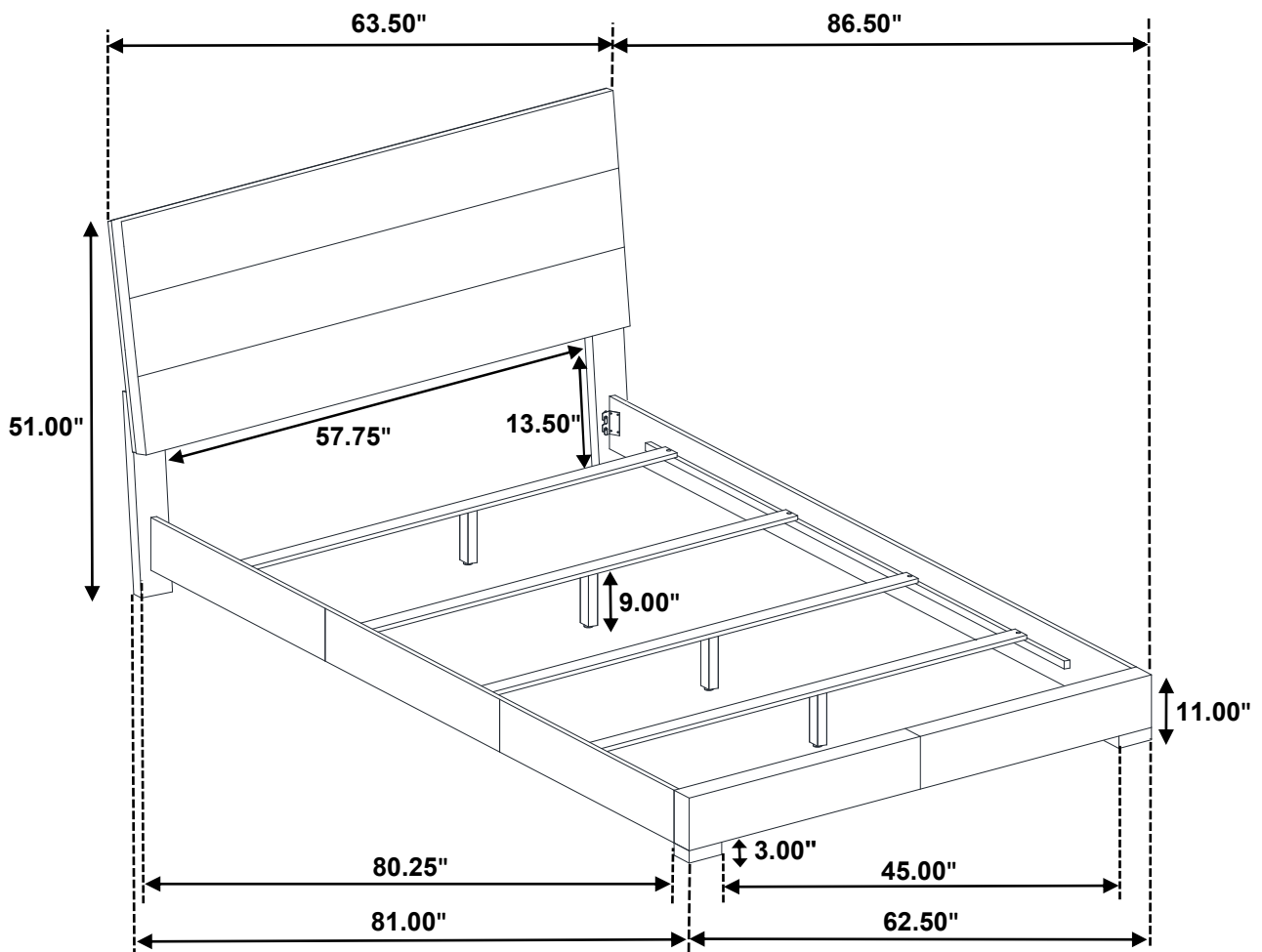

Note : Dimension tolerance $\pm 5\%$

ASSEMBLY INSTRUCTIONS
COASTER FINE FURNITURE

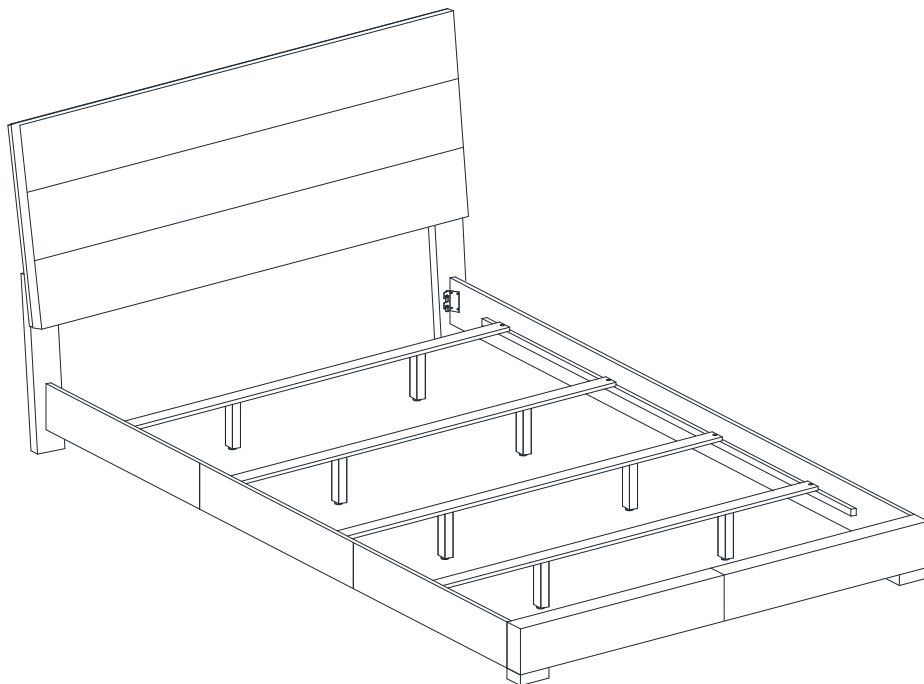

Fine Furniture for every stage of life

203501KE (B1&B2)
Eastern King Bed

ITEM: 203501KE (B1&B2)



ASSEMBLY INSTRUCTIONS

ASSEMBLY TIPS:

1. Remove hardware from box and sort by size.
2. Please check to see that all hardware and parts are present prior to start of assembly.
3. Please follow attached instructions in the same sequence as numbered to assure fast & easy assembly.



WARNING!

1. Don't attempt to repair or modify parts that are broken or defective. Please contact the store immediately.
2. This product is for home use only and not intended for commercial establishments.



ASSEMBLY TIME

30 MINUTES

PARTS IDENTIFICATION

B1 (BOX 1)

A HEADBOARD PANEL



1PC

B RIGHT HEADBOARD LEG



1PC

C LEFT HEADBOARD LEG

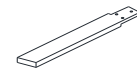

1PC

B2 (BOX 2)

D BED SLAT



4PCS

E BED SLAT SUPPORT WITH LEVELER



8PCS

F BED RAIL

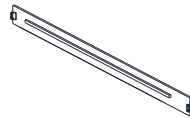

2PCS

G FOOTBOARD LEG

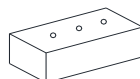

2PCS

H FOOTBOARD PANEL

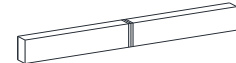

1PC

HB

203501KE (B1)
FROM BOX 1
HEADBOARD
COMPLETE

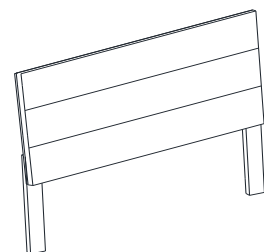

1PC

NOTE:

Phillips head screw driver is required in the assembly process; however, manufacturer does not provide this item.

ITEM: 203501KE (B1&B2)



ASSEMBLY INSTRUCTIONS

ASSEMBLY TIPS:

1. Remove hardware from box and sort by size.
2. Please check to see that all hardware and parts are present prior to start of assembly.
3. Please follow attached instructions in the same sequence as numbered to assure fast & easy assembly.







WARNING!



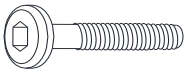

1. Don't attempt to repair or modify parts that are broken or defective. Please contact the store immediately.
2. This product is for home use only and not intended for commercial establishments.

HARDWARE IDENTIFICATION

Z-B1 (BOX 1) - HARDWARE PACK IS LOCATED IN 203501KE (B1)

1	BOLT (M6 x 30mm - BLK)		6PCS	3	FLAT WASHER (1/4" X 13mm - BLK)		6PCS
2	SMALL ALLEN WRENCH (M4 x 60MM - BLK)		1PC	4	LOCK WASHER (1/4" - BLK)		6PCS

Z-B2 (BOX 2) - HARDWARE PACK IS LOCATED IN 203501KE (B2)

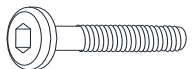
5	SHORT FLAT HEAD SCREW (M4 x 32mm - RBW)		8PCS	8	SMALL ALLEN WRENCH (M4 x 60MM - BLK)		1PC
6	LONG FLAT HEAD SCREW (M4 x 50mm - RBW)		6PCS	9	BIG ALLEN WRENCH (M5 x 65MM - BLK)		1PC
7	BOLT (M4 x 40mm - BLK)		8PCS				

NOTE:

Phillips head screw driver is required in the assembly process; however, manufacturer does not provide this item.

ITEM: 203501KE (B1&B2)



ASSEMBLY INSTRUCTIONS

STEP 1

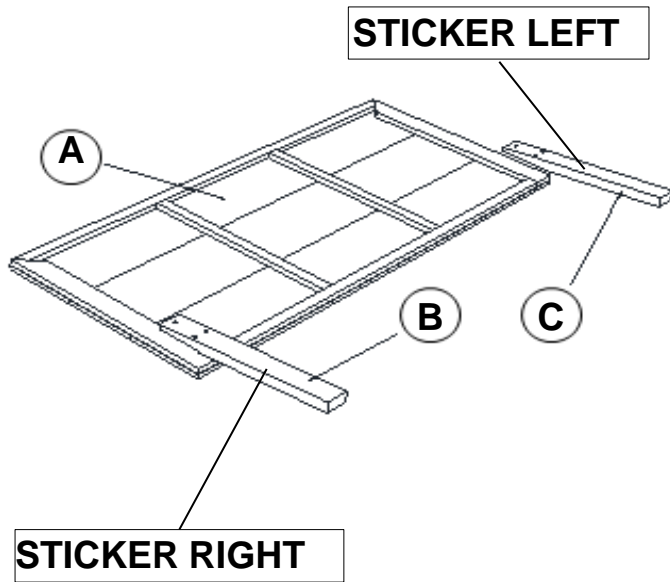

STEP 2

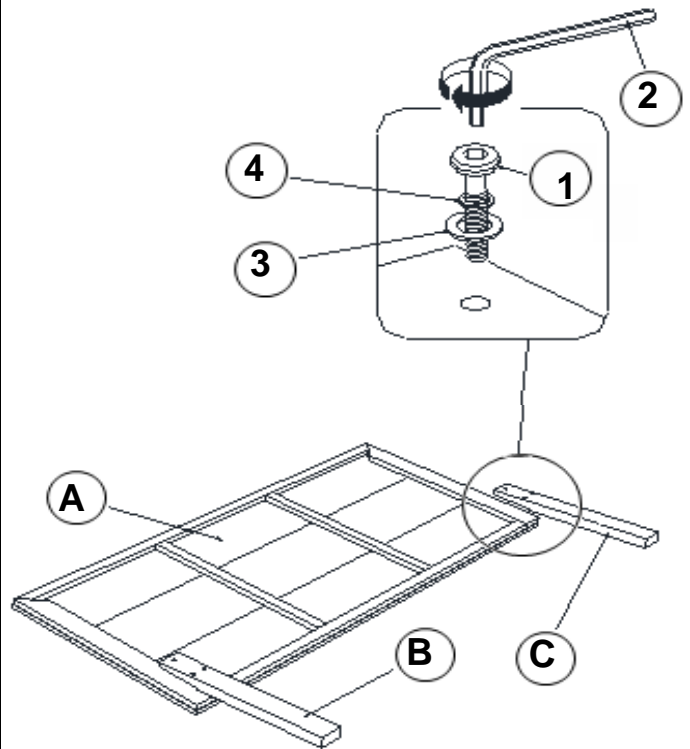

IF PURCHASE HEADBOARD ONLY, SKIP BELOW STEPS

STEP 3

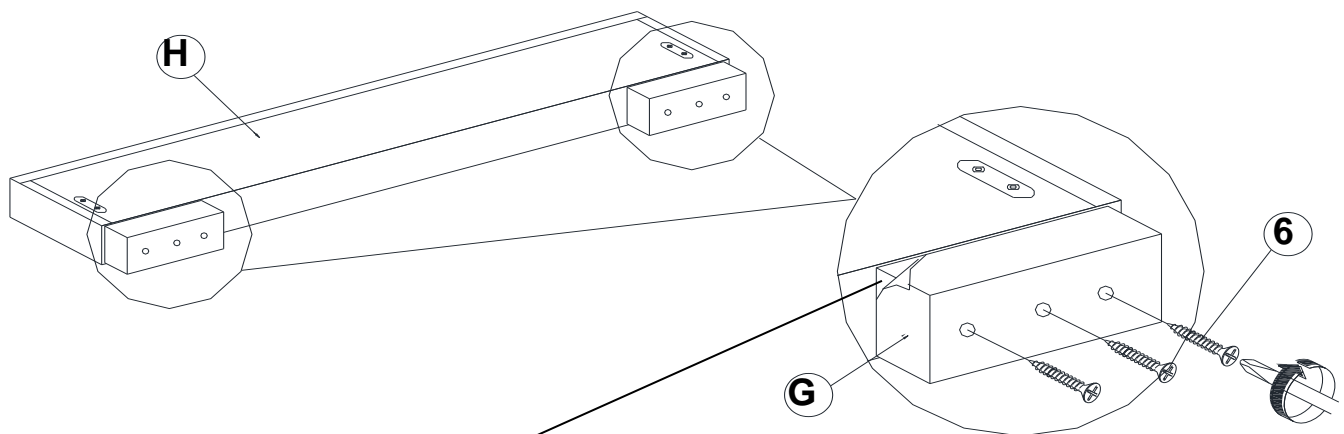

PLEASE REMOVE THE PROTECTIVE FILM BEFORE ASSEMBLY

ASSEMBLY INSTRUCTIONS

STEP 4

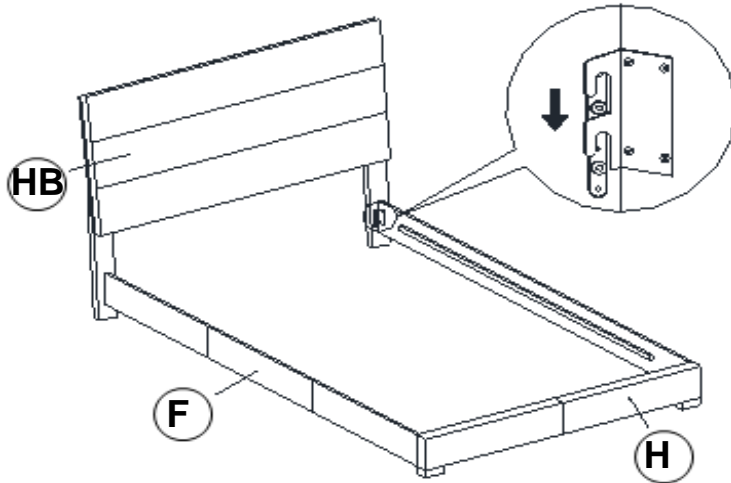

STEP 5

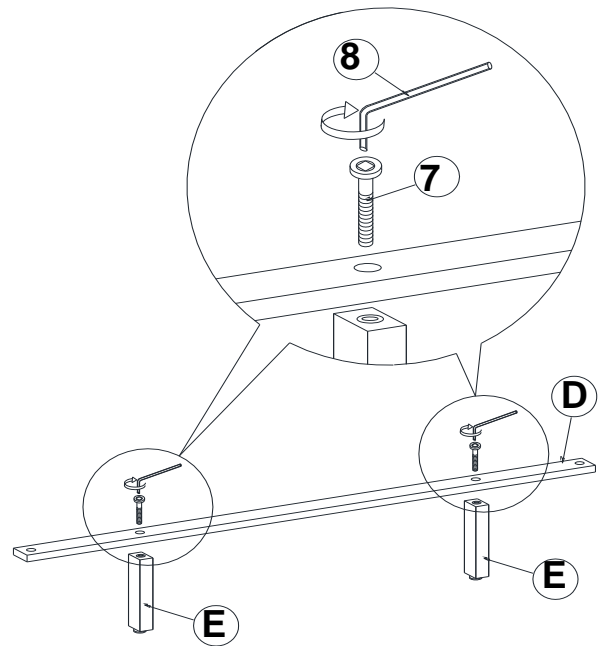

STEP 6

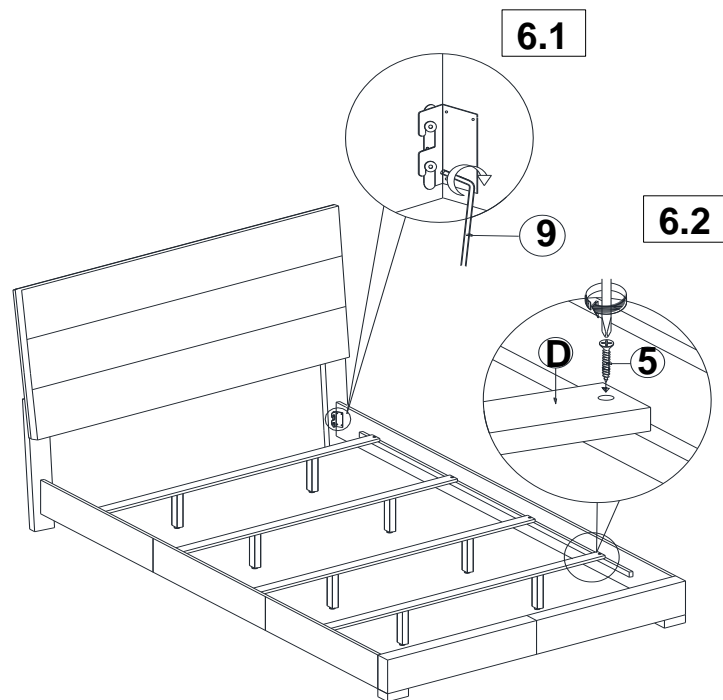

STEP 7
COMPLETE

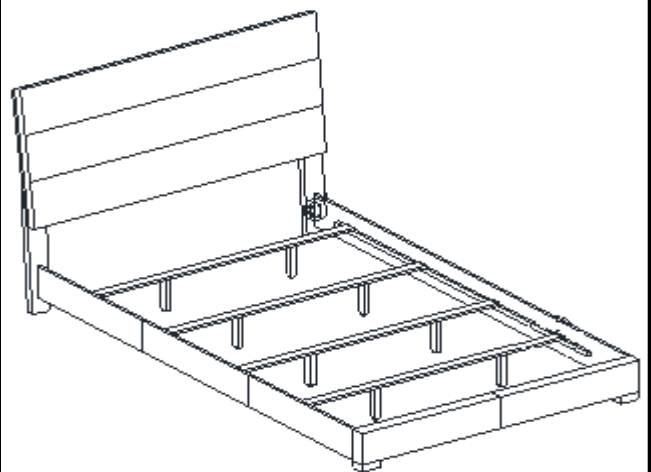

ITEM: 203501KE (B1&B2)



Inner Size : 76.75"W X 80.25"D

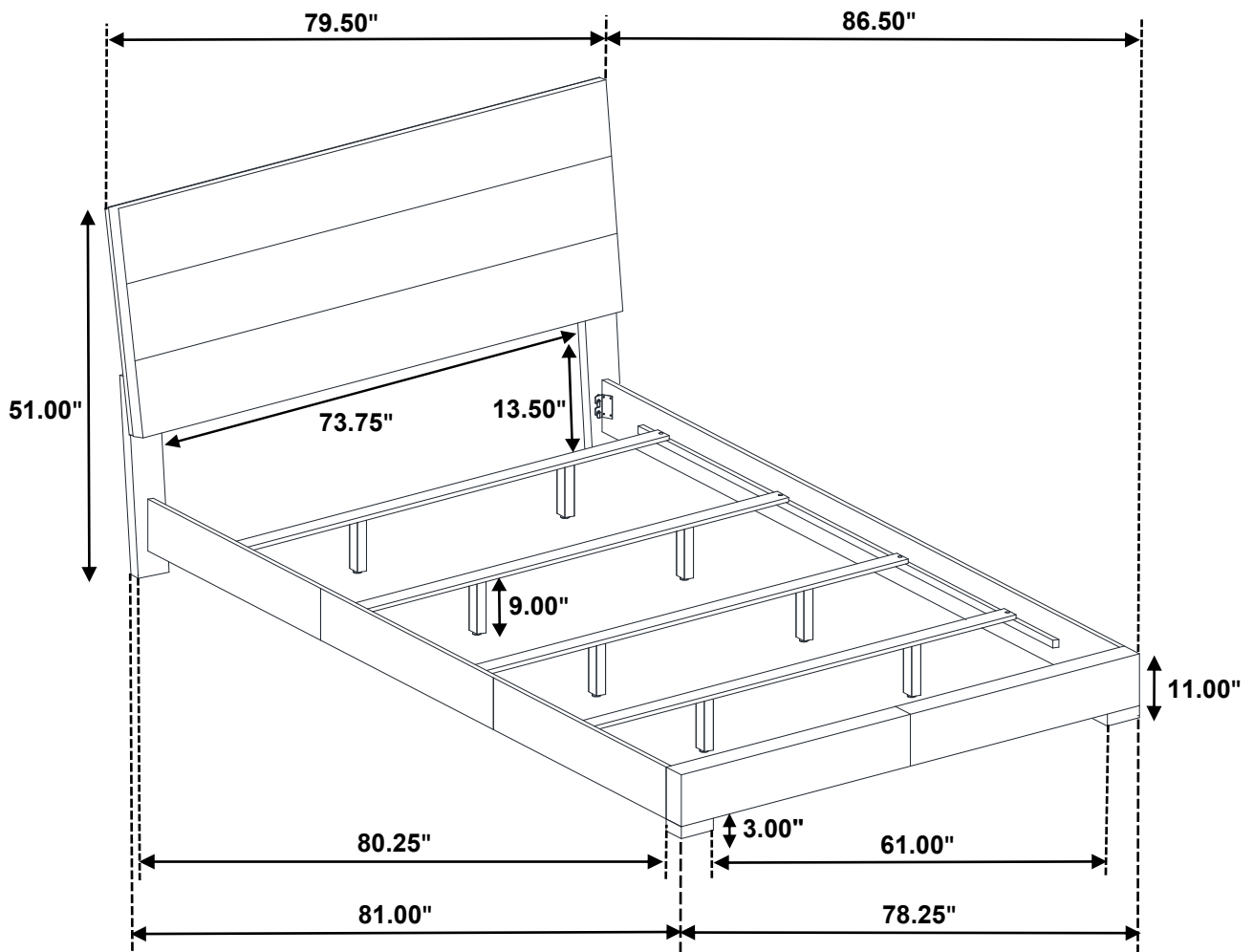

Note : Dimension tolerance $\pm 5\%$

ASSEMBLY INSTRUCTIONS
COASTER FINE FURNITURE



Fine Furniture for every stage of life

203502
Nightstand

ITEM: **203502**



ASSEMBLY INSTRUCTIONS

REMOVAL OF PROTECTIVE FILM

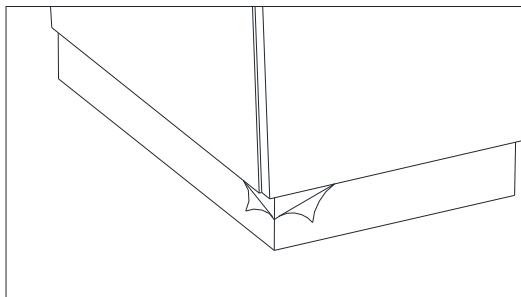
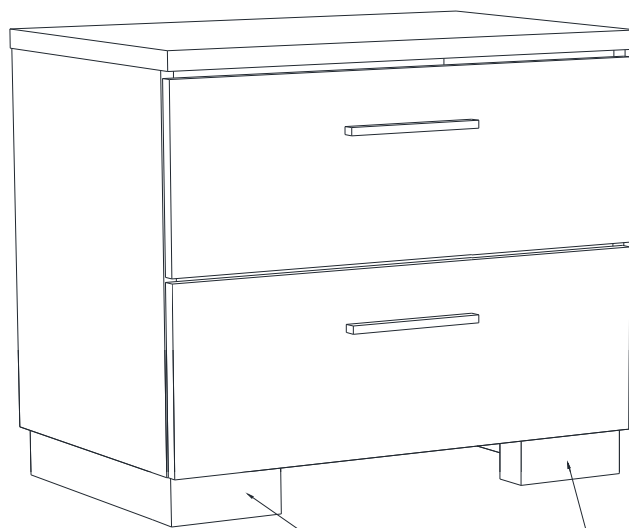

**PLEASE REMOVE THE
PROTECTIVE FILM
BEFORE USE**



ITEM:203502



Inner Size of Drawer : 20.00"W x 12.50"D x 5.00"H x 0.25"T

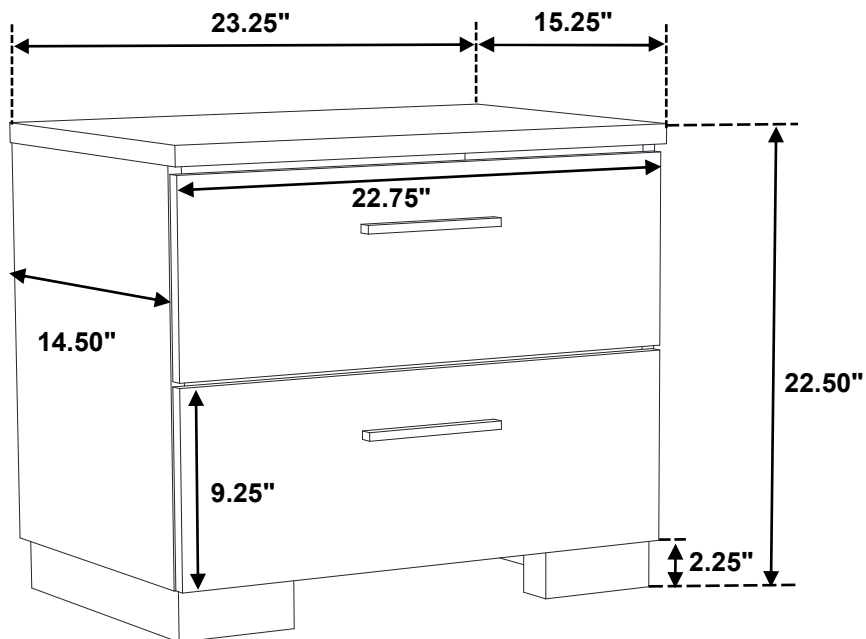

Note : Dimension tolerance $\pm 5\%$

ASSEMBLY INSTRUCTIONS
COASTER FINE FURNITURE



Fine Furniture for every stage of life

203503
Dresser

ITEM: **203503**

ASSEMBLY INSTRUCTIONS



REMOVAL OF PROTECTIVE FILM

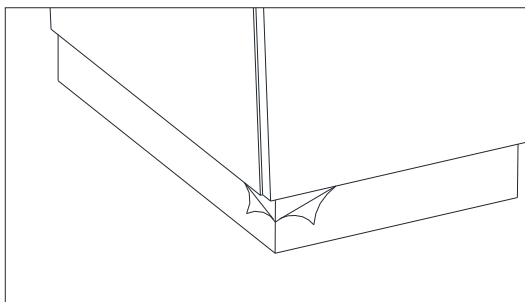

**PLEASE REMOVE THE
PROTECTIVE FILM
BEFORE USE**



ITEM:203503



Inner Size of Drawer : 28.75"W x 12.50"D x 5.00"H x 0.25"T

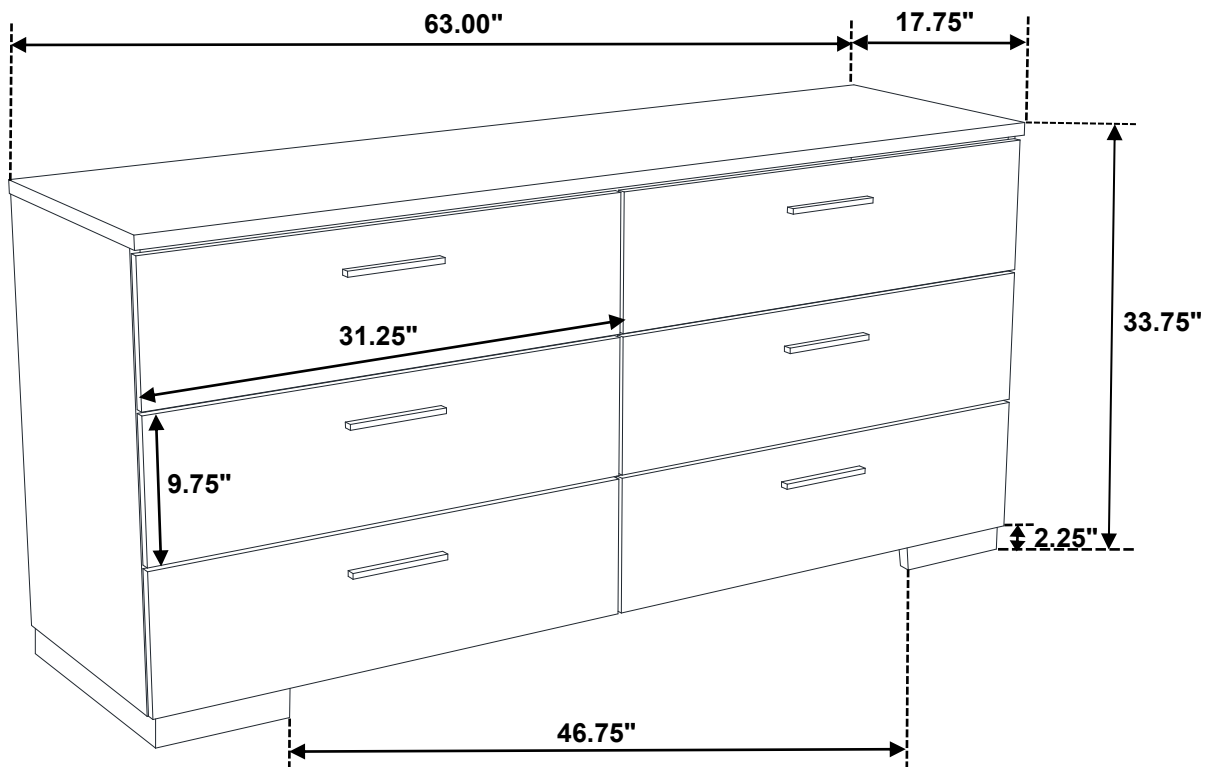

Note : Dimension tolerance $\pm 5\%$

ASSEMBLY INSTRUCTIONS
COASTER FINE FURNITURE



Fine Furniture for every stage of life

203504
Mirror

ITEM:203504



ASSEMBLY INSTRUCTIONS

ASSEMBLY TIPS:

1. Remove hardware from box and sort by size.
2. Please check to see that all hardware and parts are present prior to start of assembly.
3. Please follow attached instructions in the same sequence as numbered to assure fast & easy assembly.



WARNING!

1. Don't attempt to repair or modify parts that are broken or defective. Please contact the store immediately.
2. This product is for home use only and not intended for commercial establishments.



ASSEMBLY TIME

5 MINUTES

PARTS IDENTIFICATION

A

MIRROR

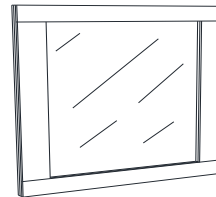

1PC

B

DRESSER
FROM BOX ITEM # 203503



1PC

C

MIRROR SUPPORT
(PACK WITH DRESSER)

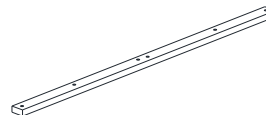

2PCS

HARDWARE IDENTIFICATION

1

FLAT HEAD SCREW
(M4 x 32mm - RBW)



10PCS

NOTE:

Phillips head screw driver is required in the assembly process; however, manufacturer does not provide this item.

ITEM: **203504**



ASSEMBLY INSTRUCTIONS

STEP 1

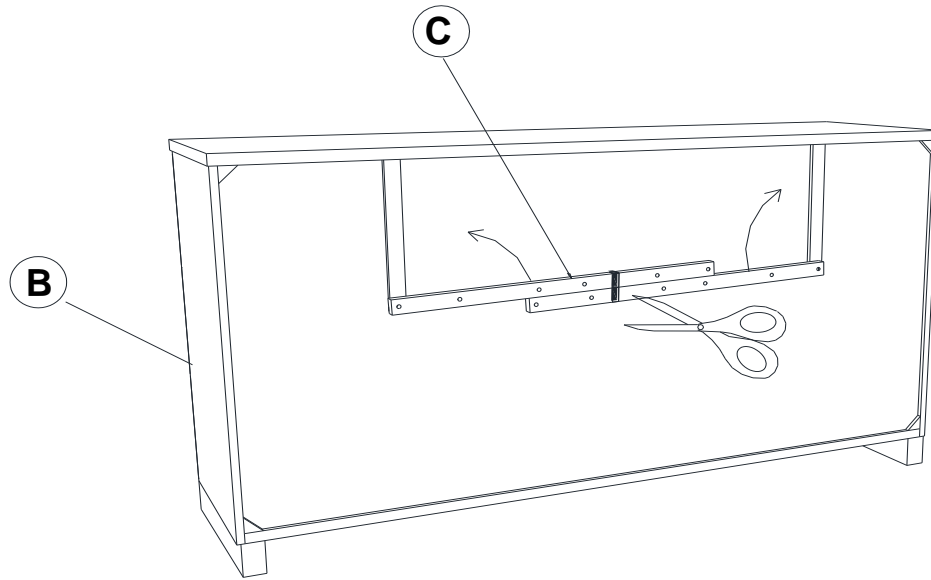

STEP 2

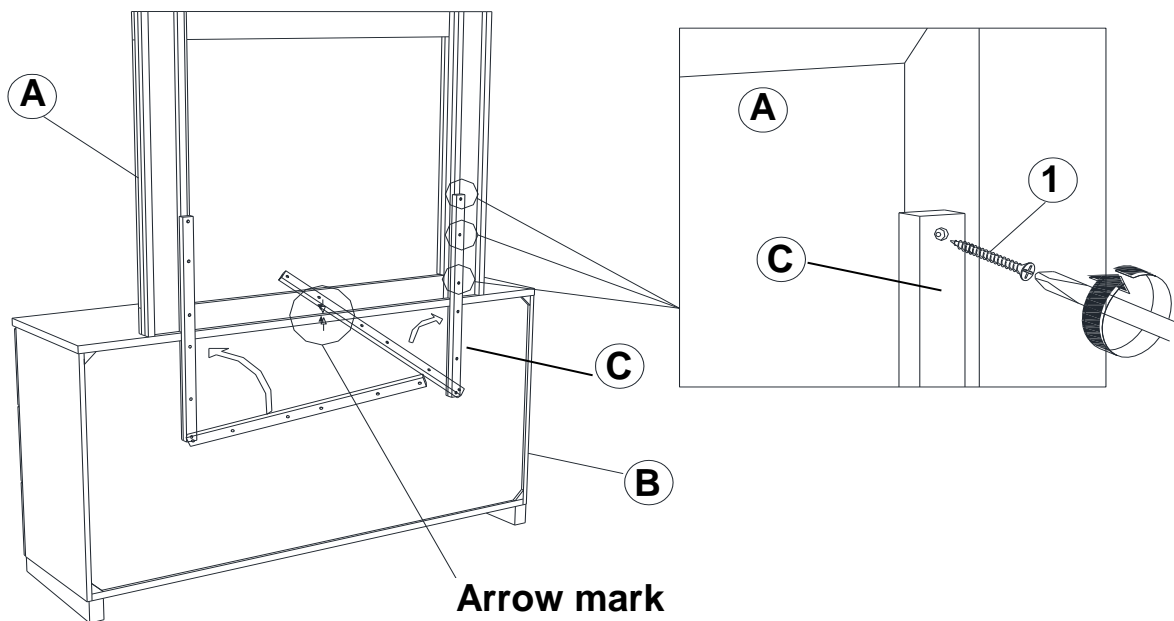

**Arrow mark
must be in line**

****BACK VIEW**

ITEM: **203504**



ASSEMBLY INSTRUCTIONS

STEP 3

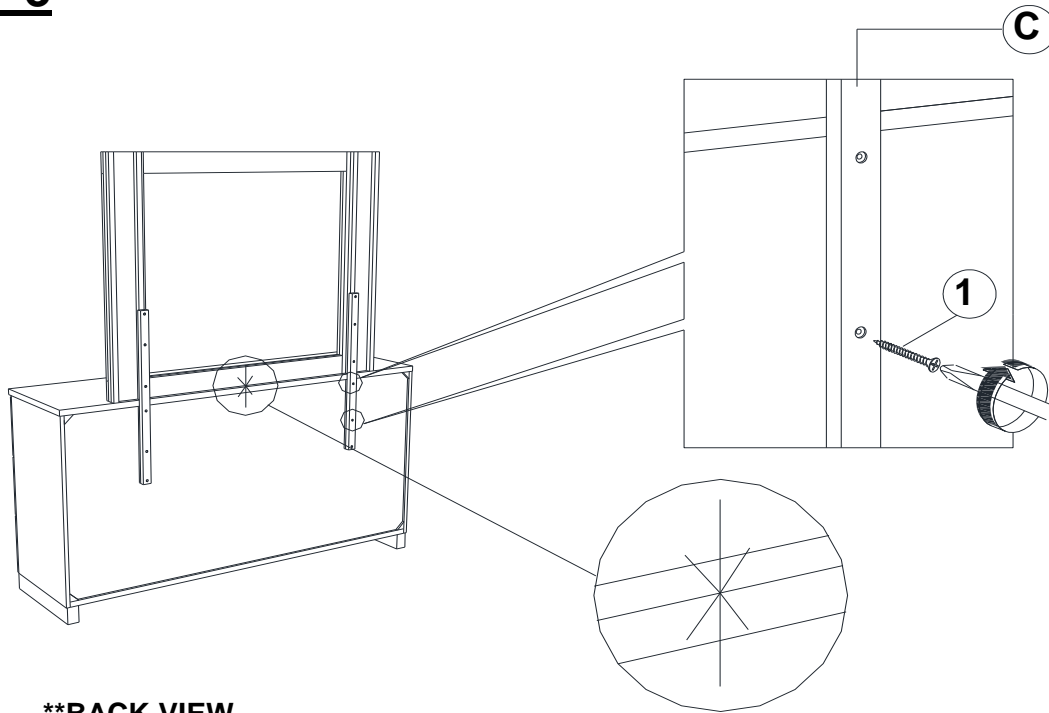

****BACK VIEW**

Arrow Marking Must Be Aligned

STEP 4

COMPLETE

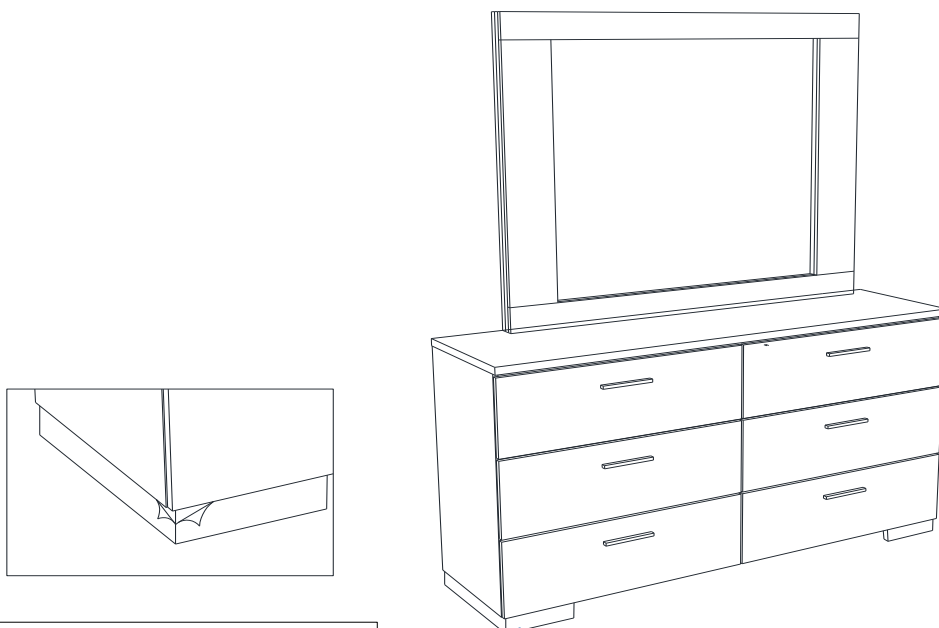

PLEASE REMOVE THE PROTECTIVE FILM BEFORE USE



ITEM:203504

COASTER
FINE FURNITURE

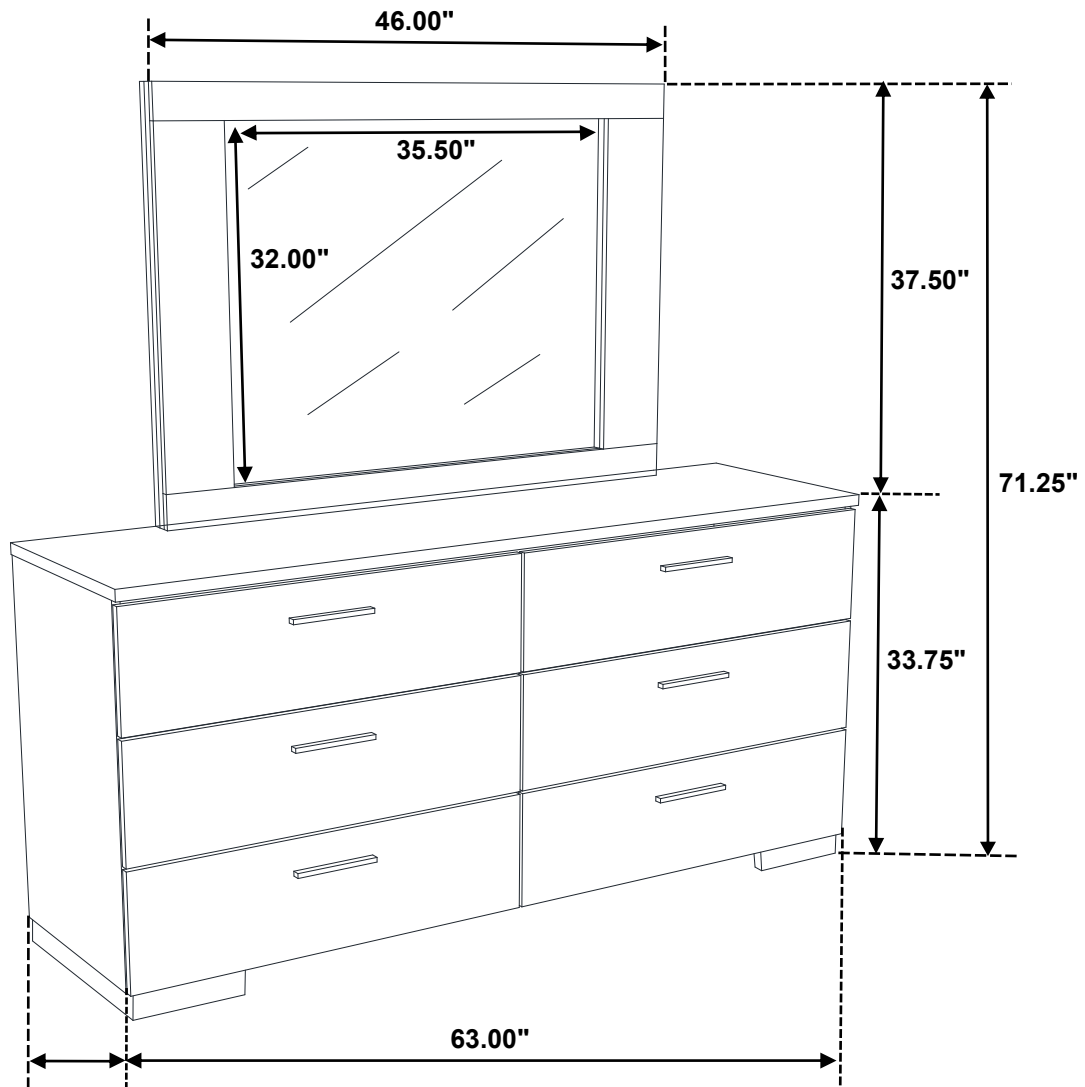

Note : Dimension tolerance $\pm 5\%$

ASSEMBLY INSTRUCTIONS
COASTER FINE FURNITURE



Fine Furniture for every stage of life

203505
Chest

ITEM: **203505**

ASSEMBLY INSTRUCTIONS



REMOVAL OF PROTECTIVE FILM

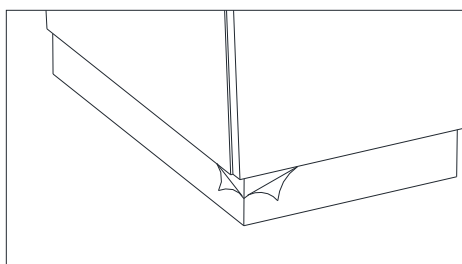

**PLEASE REMOVE THE
PROTECTIVE FILM
BEFORE USE**



ITEM:203505



Inner Size of Drawer : 32.00"W x 12.50"D x 5.00"H x 0.25"T

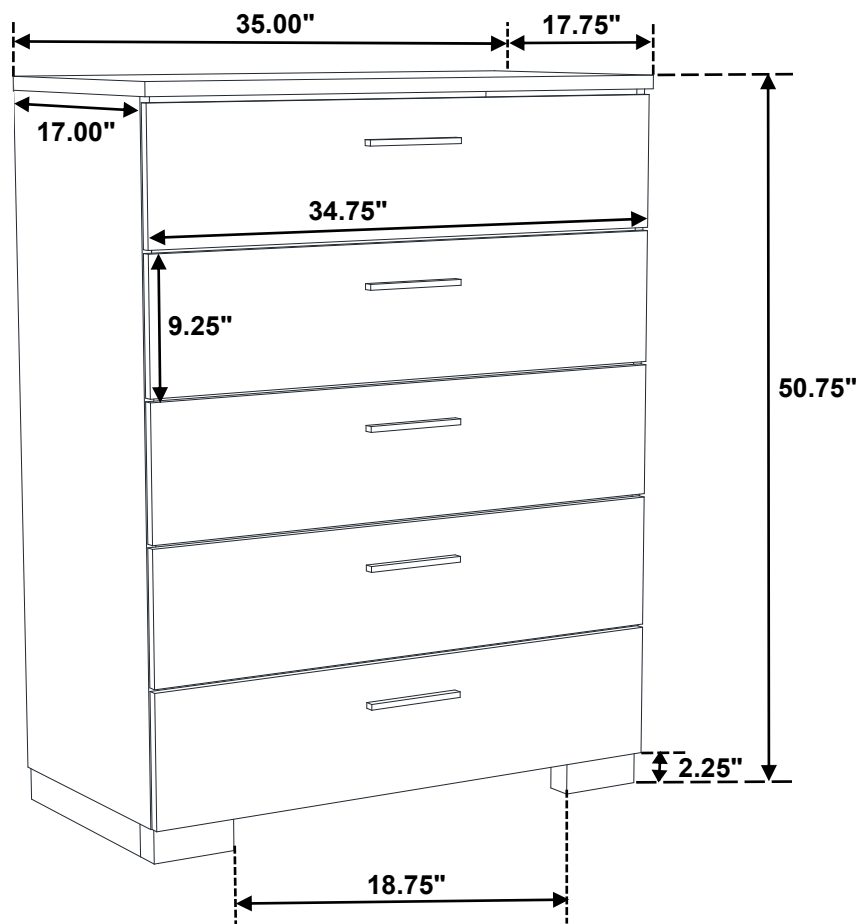

Note : Dimension tolerance \pm 5%

ASSEMBLY INSTRUCTIONS
COASTER FINE FURNITURE



Fine Furniture for every stage of life

203507(B1&B2)
Vanity Mirror & Desk

ITEM: 203507(B1&B2)

ASSEMBLY INSTRUCTIONS

ASSEMBLY TIPS:

1. Remove hardware from box and sort by size.
2. Please check to see that all hardware and parts are present prior to start of assembly.
3. Please follow attached instructions in the same sequence as numbered to assure fast & easy assembly.



WARNING!

1. Don't attempt to repair or modify parts that are broken or defective. Please contact the store immediately.
2. This product is for home use only and not intended for commercial establishments.



ASSEMBLY TIME

10 MINUTES

PARTS IDENTIFICATION

B1 (BOX 1)

A MIRROR

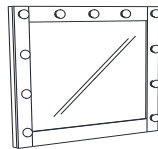

1PC

C ADAPTOR



1PC

B MIRROR SUPPORT



2PCS

B2 (BOX 2)

D DESKTOP

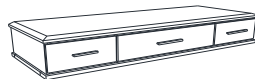

1PC

F COMPARTMENT



2PCS

E BACK PANEL



1PC

HARDWARE IDENTIFICATION

Z-B1 (BOX 1) - HARDWARE PACK IS LOCATED IN 203507 (B1)

LONG FLAT HEAD
1 SCREW
(M4 x 32mm - RBW)



8PCS

Z-B2 (BOX 2) - HARDWARE PACK IS LOCATED IN 203507 (B2)

2 ALLEN WRENCH
(M4 x 60MM - BLK)



1PC

5 LOCK WASHER
(1/4" - BLK)



2PCS

3 SHORT FLAT HEAD SCREW
(M4 x 25mm - RBW)



11PCS

6 FLAT WASHER
(1/4" X 19mm - BLK)



2PCS

4 BOLT
(M6 x 30mm - BLK)

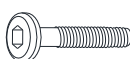

2PCS

7 WOOD DOWEL
(M6 x 20mm)



4PCS

ITEM: **203507(B1&B2)**

ASSEMBLY INSTRUCTIONS

STEP 1

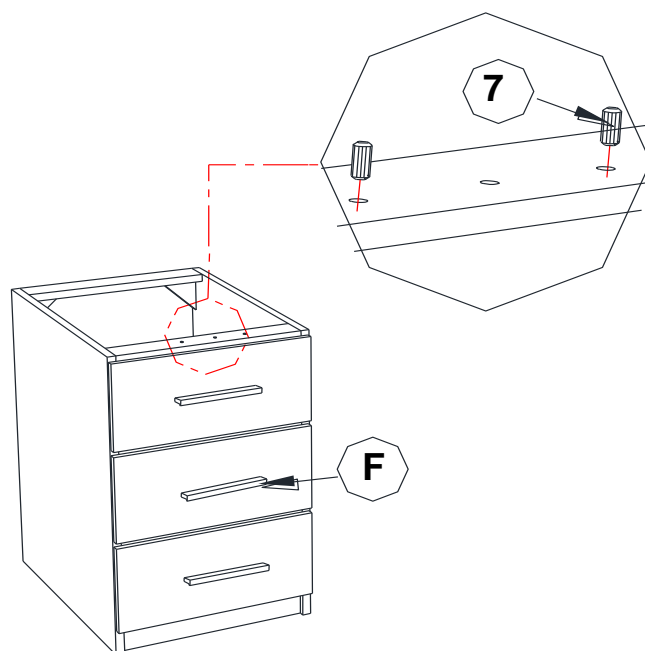

STEP 2

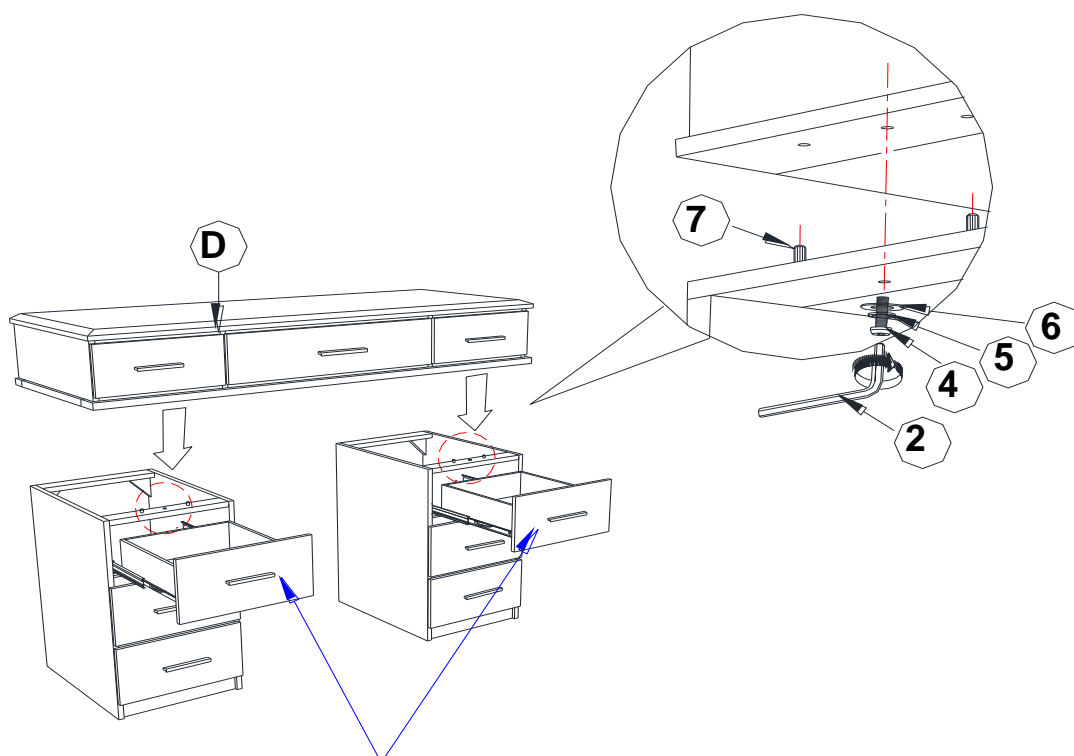

REMARK : Pull out drawer for easy assembly process

ITEM: **203507(B1&B2)**

ASSEMBLY INSTRUCTIONS

STEP 3

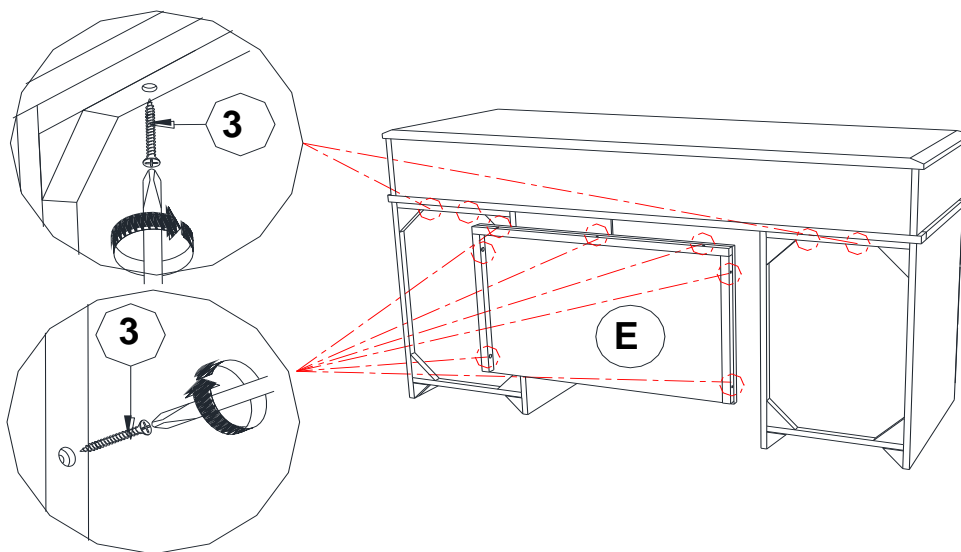

STEP 4
COMPLETE



ITEM: 203507(B1&B2)

ASSEMBLY INSTRUCTIONS

STEP 5

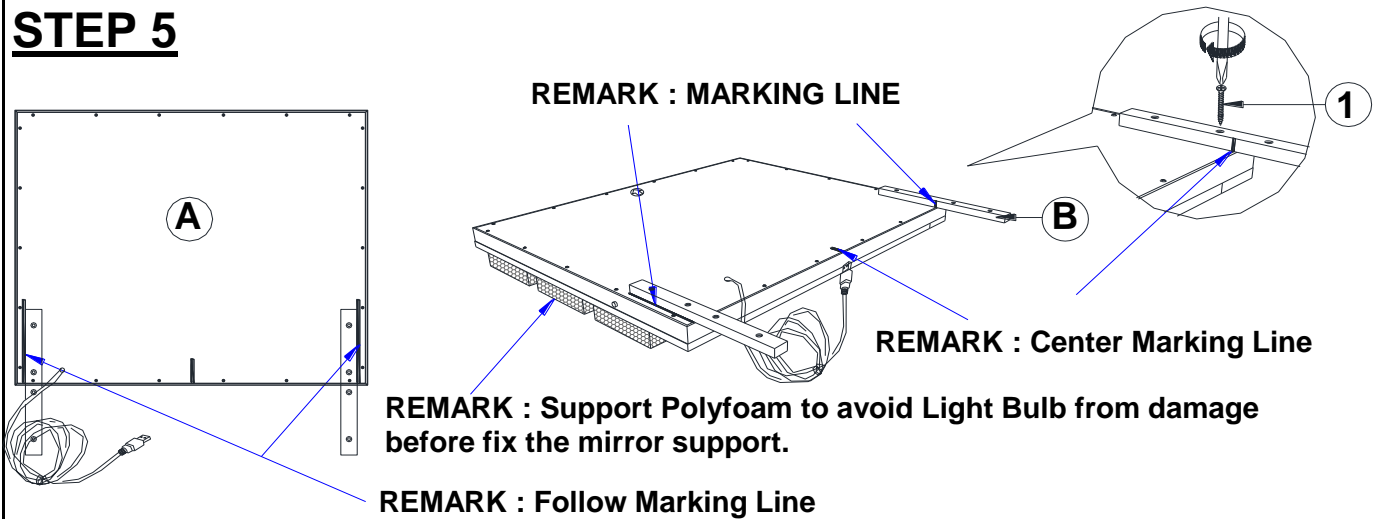

STEP 6

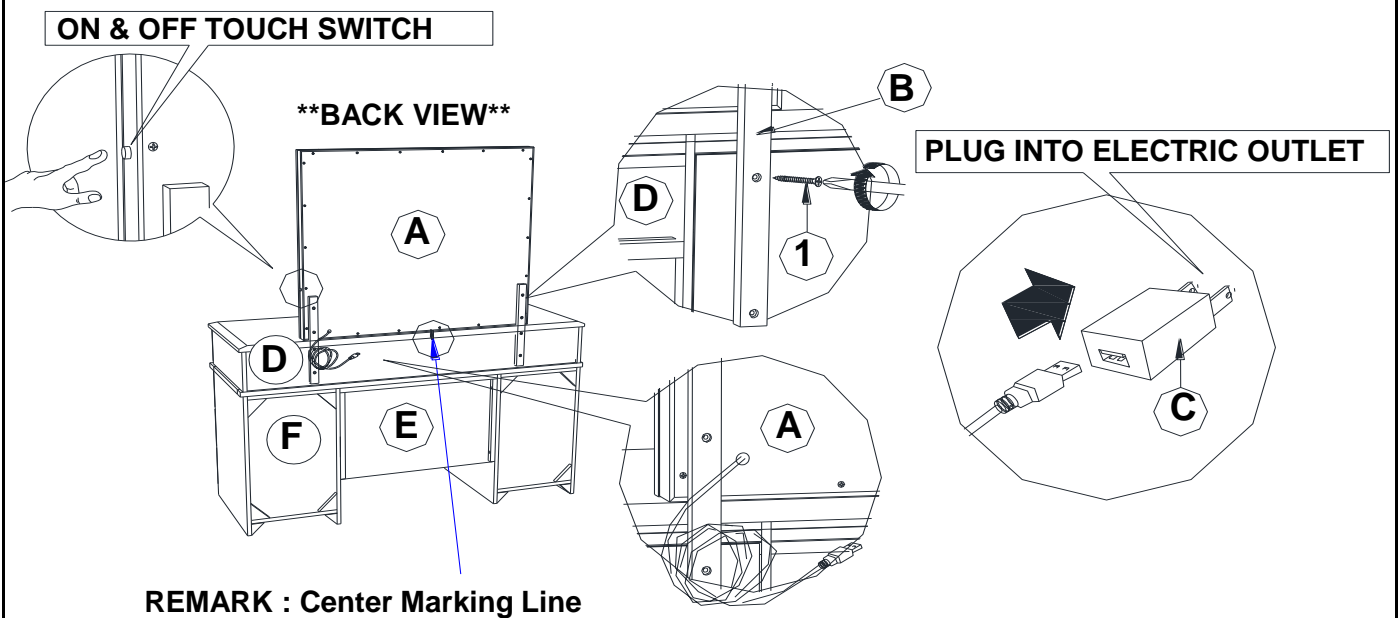

STEP 7 COMPLETE

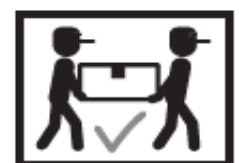
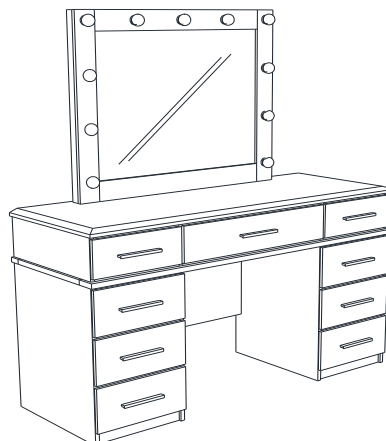

ITEM: 203507(B1&B2)



Inner Size of Drawer (Top Center) : 23.25"W X 12.50"D X 3.00"H X 0.25"T
Inner Size of Drawer (Others) : 12.50"W X 11.25"D X 3.00"H X 0.25"T

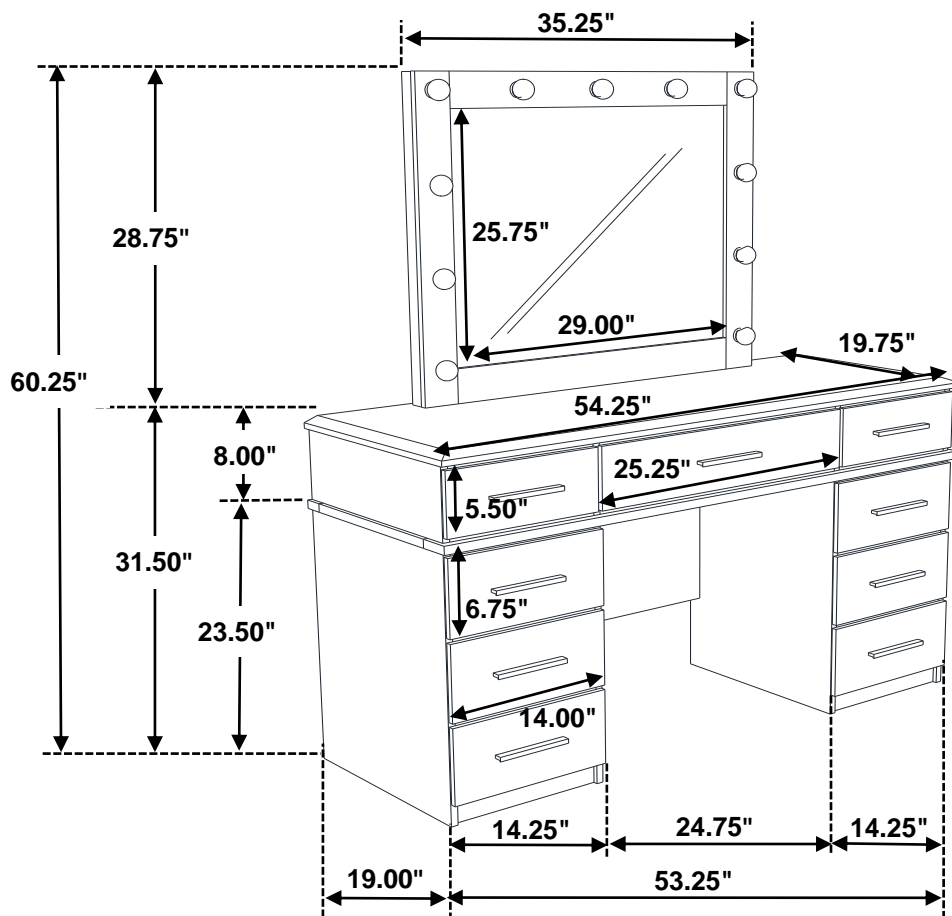

Note : Dimension tolerance $\pm 5\%$

ASSEMBLY INSTRUCTIONS
COASTER FINE FURNITURE



Fine Furniture for every stage of life

203507STL
Stool

ITEM: 203507STL



ASSEMBLY INSTRUCTIONS

ASSEMBLY TIPS:

1. Remove hardware from box and sort by size.
2. Please check to see that all hardware and parts are present prior to start of assembly.
3. Please follow attached instructions in the same sequence as numbered to assure fast & easy assembly.



WARNING!

1. Don't attempt to repair or modify parts that are broken or defective. Please contact the store immediately.
2. This product is for home use only and not intended for commercial establishments.



ASSEMBLY TIME

10 MINUTES

PARTS IDENTIFICATION

A SEAT

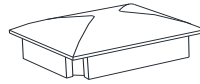

1PC

B LEG



4PCS

HARDWARE IDENTIFICATION

1 ALLEN WRENCH
(M4 x 60MM - BLK)



1PC

2 BOLT
(M6 x 50mm - BLK)

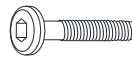

8PCS

3 LOCK WASHER
(1/4" - BLK)



8PCS

4 FLAT WASHER
(1/4" X 19mm - BLK)



8PCS

ITEM: **203507STL**



ASSEMBLY INSTRUCTIONS

STEP 1

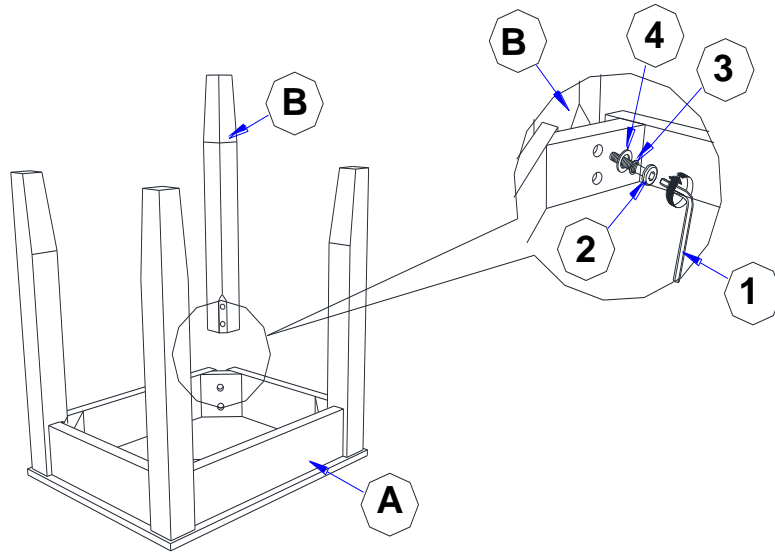

STEP 2
COMPLETE

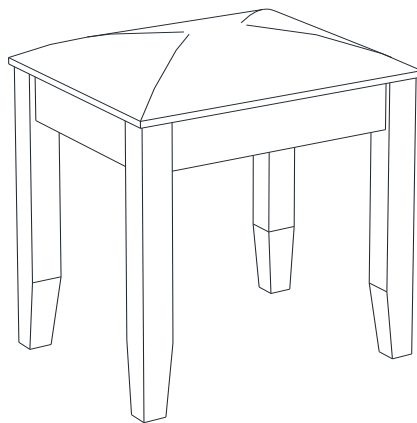

ITEM: **203507STL**

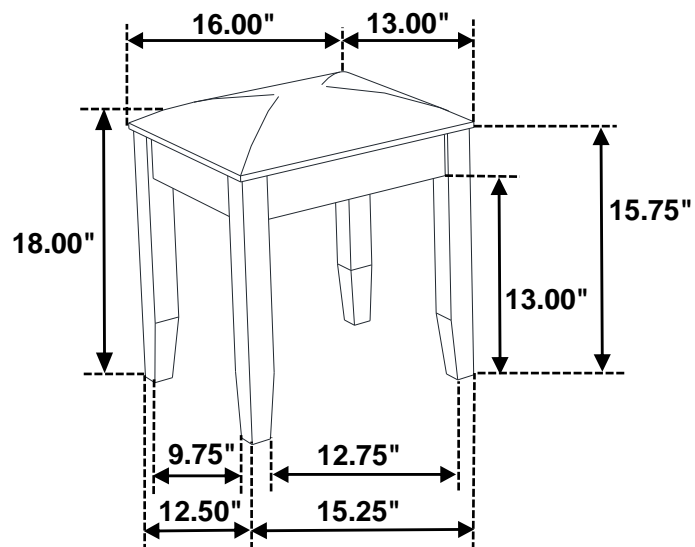

Note : Dimension tolerance \pm 5%