

ASSEMBLY INSTRUCTIONS
COASTER FINE FURNITURE

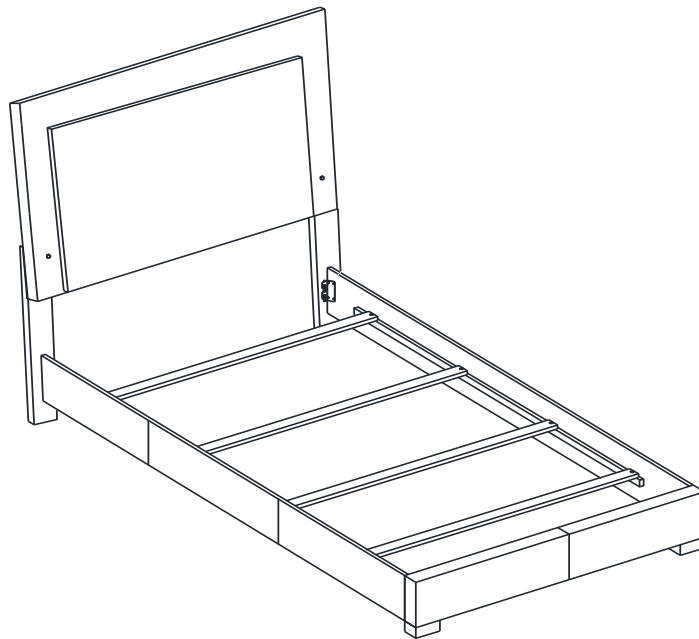

Fine Furniture for every stage of life

203500T (B1&B2)
Twin Bed

ITEM: 203500T (B1&B2)



ASSEMBLY INSTRUCTIONS

ASSEMBLY TIPS:

1. Remove hardware from box and sort by size.
2. Please check to see that all hardware and parts are present prior to start of assembly.
3. Please follow attached instructions in the same sequence as numbered to assure fast & easy assembly.



WARNING!

1. Don't attempt to repair or modify parts that are broken or defective. Please contact the store immediately.
2. This product is for home use only and not intended for commercial establishments.





ASSEMBLY TIME



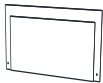

20 MINUTES

PARTS IDENTIFICATION

B1 (BOX 1)

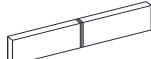
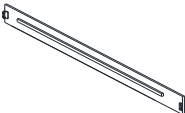
A	HEADBOARD PANEL		1PC	C	LEFT HEADBOARD LEG		1PC
B	RIGHT HEADBOARD LEG		1PC				

B2 (BOX 2)

D	BED SLAT		4PCS	G	FOOTBOARD PANEL		1PC
E	BED RAIL		2PCS	H	ADAPTER PLUG		1PC
F	FOOTBOARD LEG		2PCS	HB	203500T (B1) FROM BOX 1 HEADBOARD COMPLETE		1PC

ITEM: 203500T (B1 & B2)



ASSEMBLY INSTRUCTIONS

ASSEMBLY TIPS:

1. Remove hardware from box and sort by size.
2. Please check to see that all hardware and parts are present prior to start of assembly.
3. Please follow attached instructions in the same sequence as numbered to assure fast & easy assembly.



WARNING!

1. Don't attempt to repair or modify parts that are broken or defective. Please contact the store immediately.
2. This product is for home use only and not intended for commercial establishments.

HARDWARE IDENTIFICATION

Z-B1 (BOX 1) - HARDWARE PACK IS LOCATED IN 203500T (B1)

1 **BOLT**
(M6 x 30mm - BLK)



3 **FLAT WASHER**
(1/4" X 13mm - BLK)



2 **ALLEN WRENCH**
(M4 x 60mm - BLK)



4 **LOCK WASHER**
(1/4" - BLK)



Z-B2 (BOX 2) - HARDWARE PACK IS LOCATED IN 203500T (B2)

5 **SHORT FLAT HEAD
SCREW**
(M4 x 32mm - RBW)



7 **ALLEN WRENCH**
(M5 x 65MM - BLK)



6 **LONG FLAT HEAD
SCREW**
(M4 x 50mm - RBW)



NOTE:

Phillips head screw driver is required in the assembly process; however, manufacturer does not provide this item.

ASSEMBLY INSTRUCTIONS

STEP 1

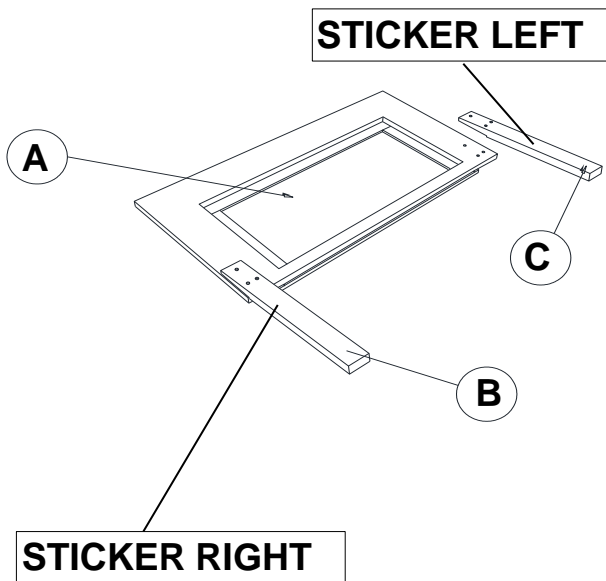

STEP 2

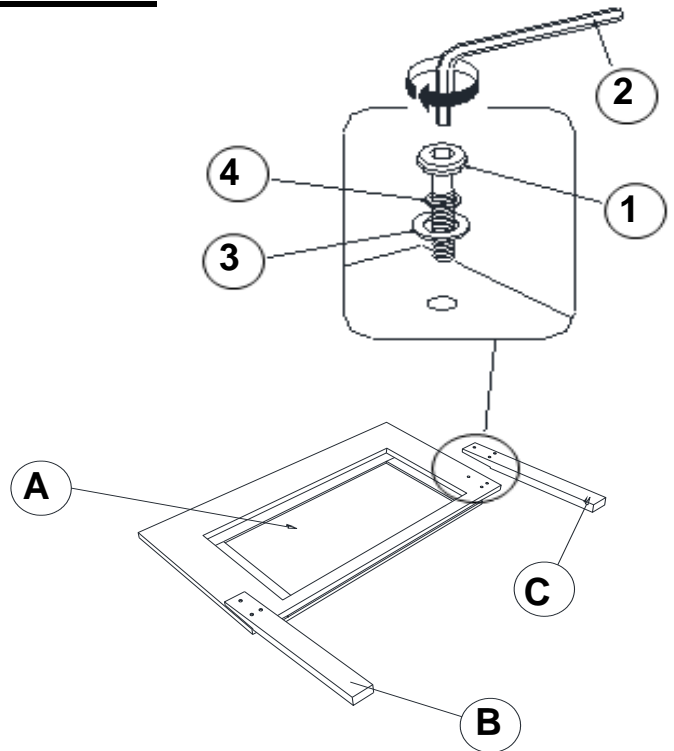

IF PURCHASE HEADBOARD ONLY, SKIP BELOW STEPS

STEP 3

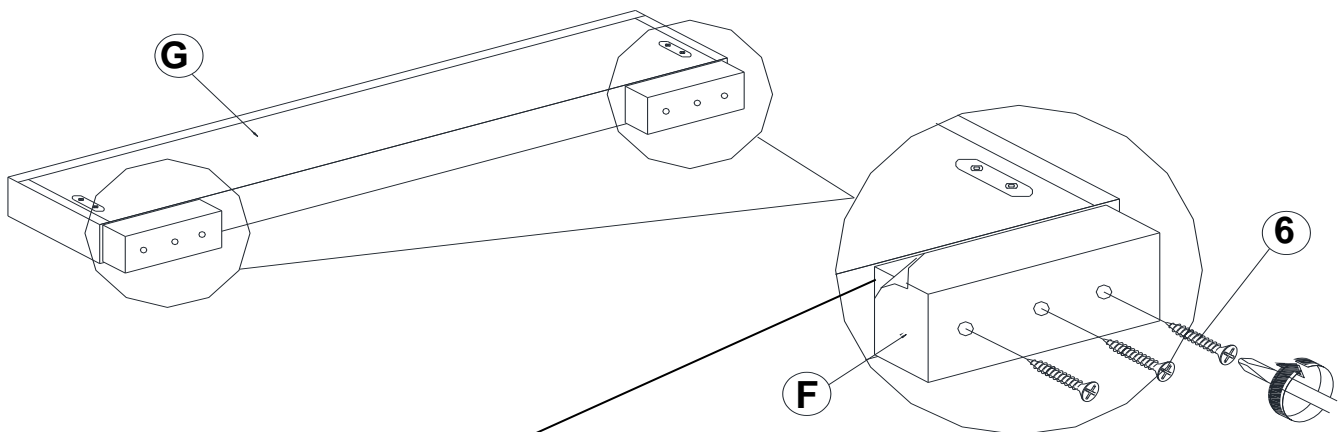

PLEASE REMOVE THE PROTECTIVE FILM BEFORE ASSEMBLY

ITEM: 203500T (B1&B2)



ASSEMBLY INSTRUCTIONS

STEP 4

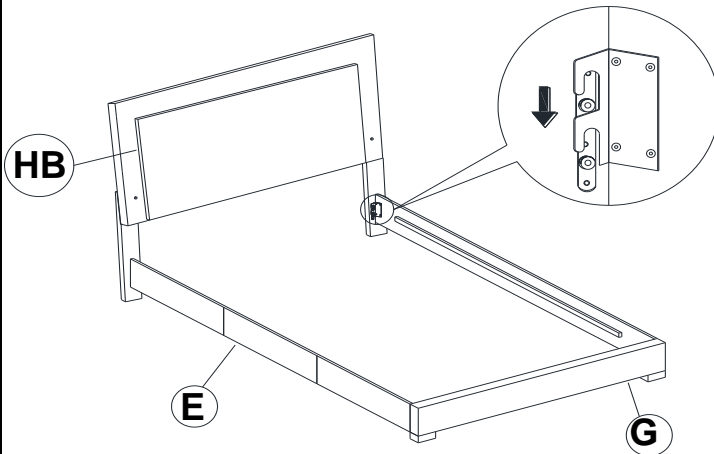

STEP 5

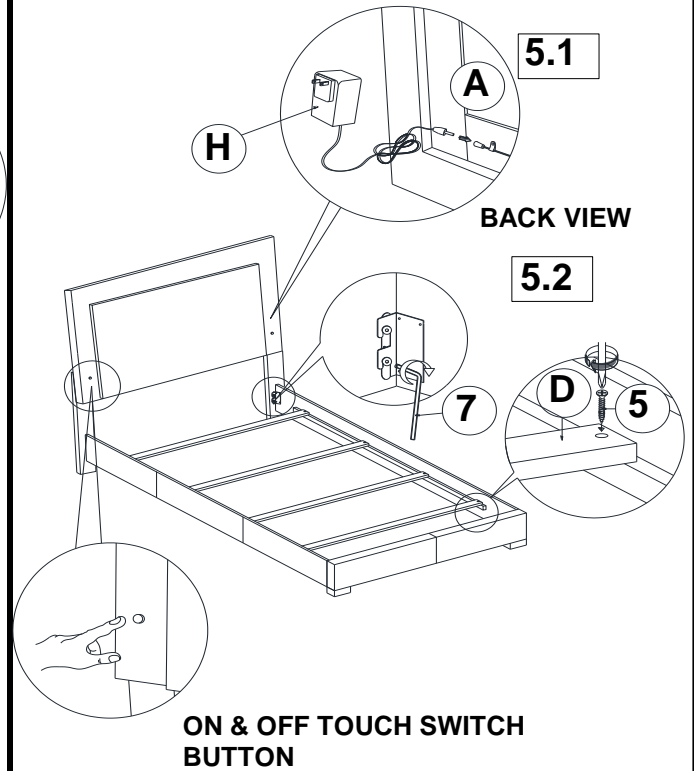

STEP 6 COMPLETE

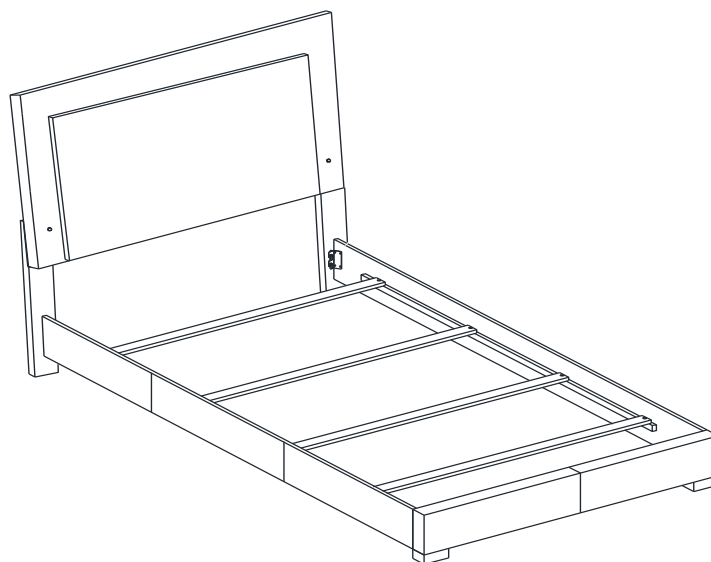

ITEM: 203500T (B1&B2)

Inner Size : 39.50"W X 76.00"D

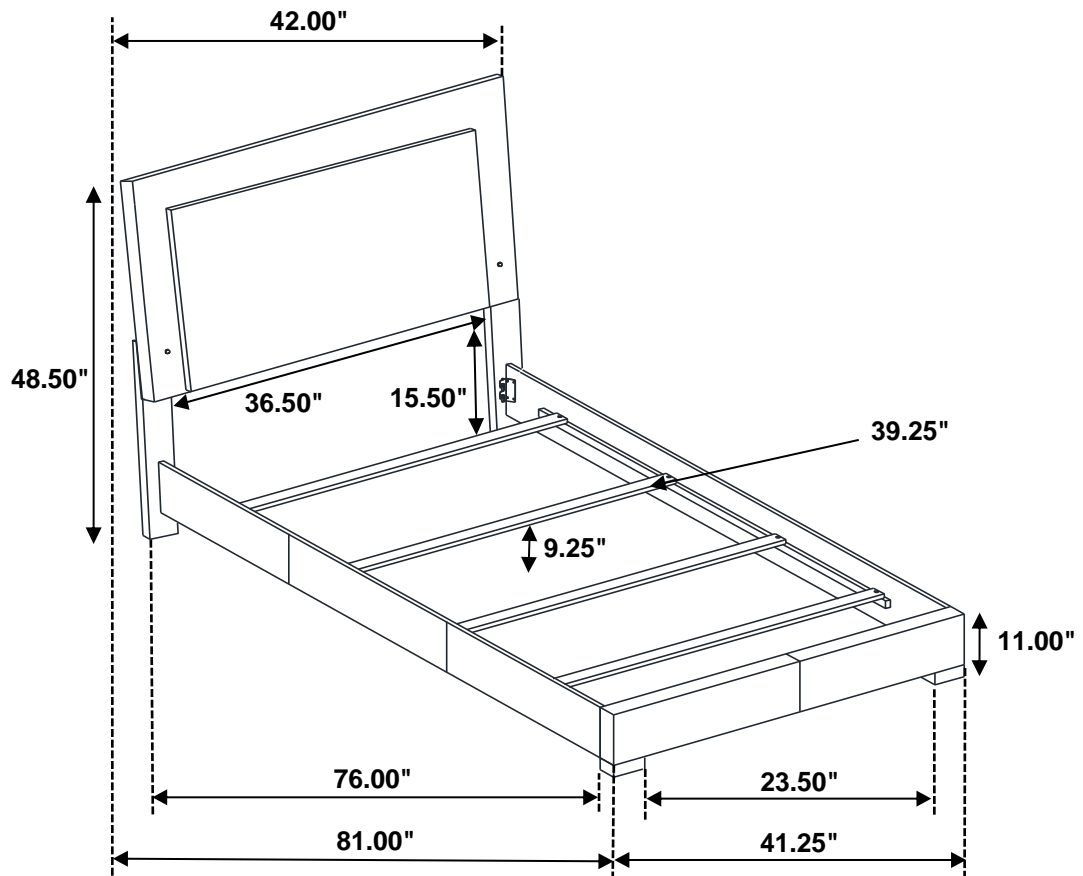

Note : Dimension tolerance $\pm 5\%$

ASSEMBLY INSTRUCTIONS
COASTER FINE FURNITURE

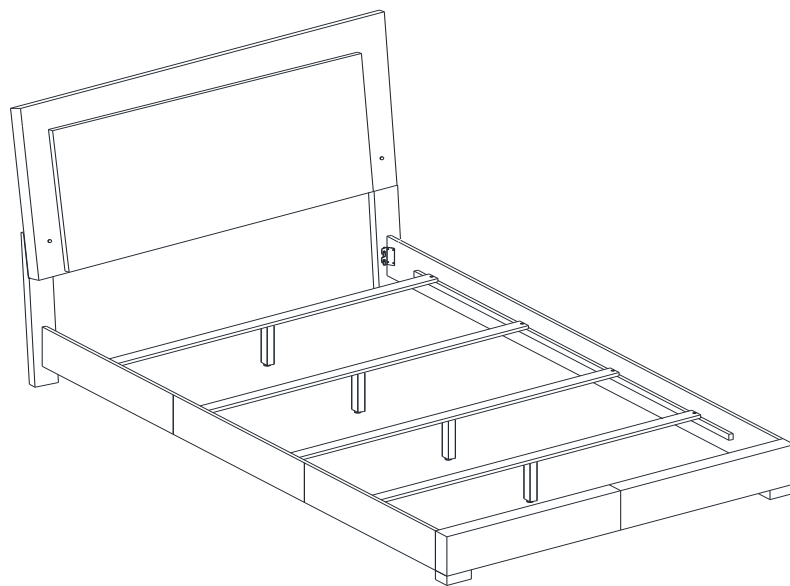

Fine Furniture for every stage of life

203500F (B1 & B2)
Full Bed

ITEM: 203500F (B1&B2)



ASSEMBLY INSTRUCTIONS

ASSEMBLY TIPS:

1. Remove hardware from box and sort by size.
2. Please check to see that all hardware and parts are present prior to start of assembly.
3. Please follow attached instructions in the same sequence as numbered to assure fast & easy assembly.

WARNING!



1. Don't attempt to repair or modify parts that are broken or defective. Please contact the store immediately.
2. This product is for home use only and not intended for commercial establishments.

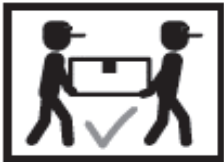



ASSEMBLY TIME





20 MINUTES

PARTS IDENTIFICATION

B1 (BOX 1)

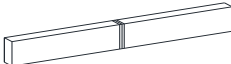
A	HEADBOARD PANEL		1PC	C	LEFT HEADBOARD LEG		1PC
B	RIGHT HEADBOARD LEG		1PC				

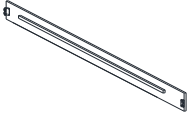
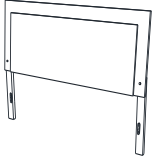
B2 (BOX 2)

D	BED SLAT		4PCS	H	FOOTBOARD PANEL		1PC
E	BED SLAT SUPPORT WITH LEVELER		4PCS	I	ADAPTER PLUG		1PC
F	BED RAIL		2PCS	HB	203500F (B1) FROM BOX 1 HEADBOARD COMPLETE		1PC
G	FOOTBOARD LEG		2PCS				

ITEM: 203500F (B1&B2)

ASSEMBLY INSTRUCTIONS

ASSEMBLY TIPS:

1. Remove hardware from box and sort by size.
2. Please check to see that all hardware and parts are present prior to start of assembly.
3. Please follow attached instructions in the same sequence as numbered to assure fast & easy assembly.







WARNING!



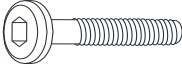

1. Don't attempt to repair or modify parts that are broken or defective. Please contact the store immediately.
2. This product is for home use only and not intended for commercial establishments.

HARDWARE IDENTIFICATION

Z-B1 (BOX 1) - HARDWARE PACK IS LOCATED IN 203500F (B1)

1	BOLT (M6 x 30mm - BLK)		6PCS	3	FLAT WASHER (1/4" X 13mm - BLK)		6PCS
2	SMALL ALLEN WRENCH (M4 x 60mm - BLK)		1PC	4	LOCK WASHER (1/4" - BLK)		6PCS

Z-B2 (BOX 2) - HARDWARE PACK IS LOCATED IN 203500F (B2)

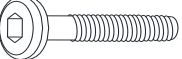
5	SHORT FLAT HEAD SCREW (M4 x 32mm - RBW)		8PCS	8	SMALL ALLEN WRENCH (M4 x 60mm - BLK)		1PC
6	LONG FLAT HEAD SCREW (M4 x 50mm - RBW)		6PCS	9	BIG ALLEN WRENCH (M5 x 65mm - BLK)		1PC
7	BOLT (M6 x 40mm - BLK)		4PCS				

NOTE:

Phillips head screw driver is required in the assembly process; however, manufacturer does not provide this item.

ASSEMBLY INSTRUCTIONS

STEP 1

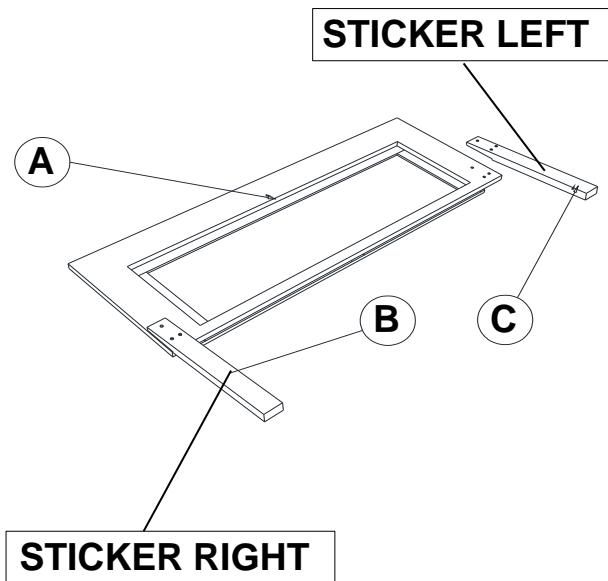

STEP 2

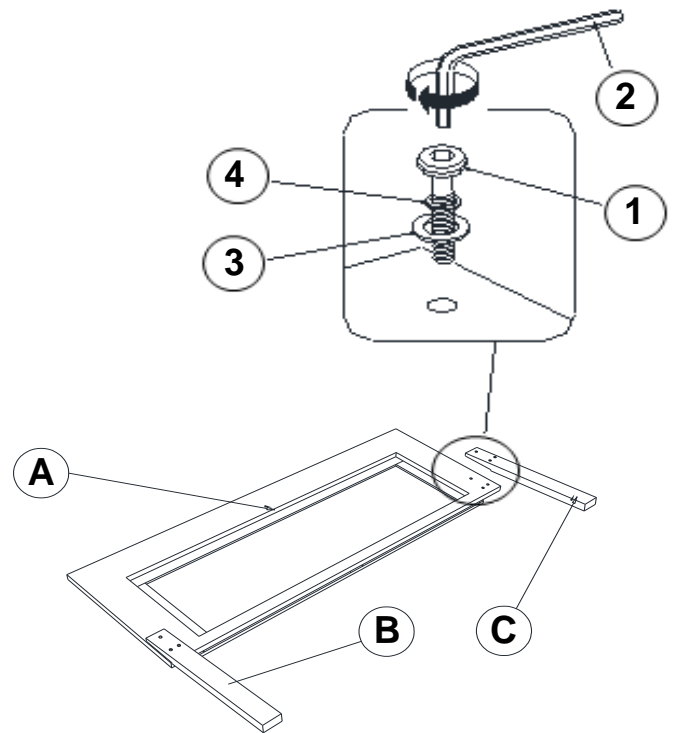

IF PURCHASE HEADBOARD ONLY, SKIP BELOW STEPS

STEP 3

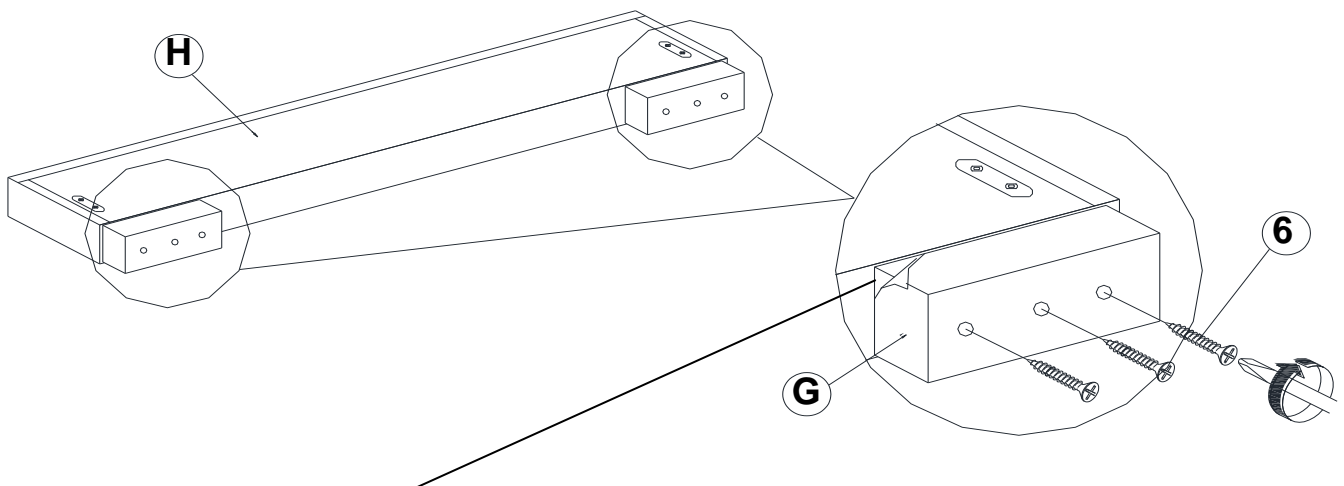

PLEASE REMOVE THE PROTECTIVE FILM BEFORE ASSEMBLY

ITEM: 203500F (B1&B2)



ASSEMBLY INSTRUCTIONS

STEP 4

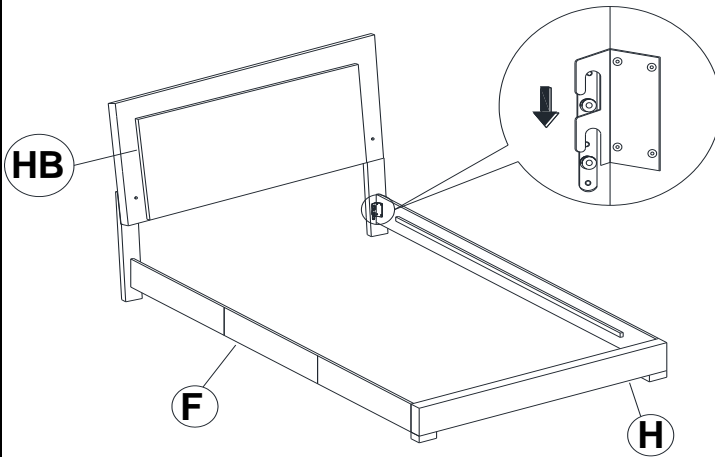

STEP 5

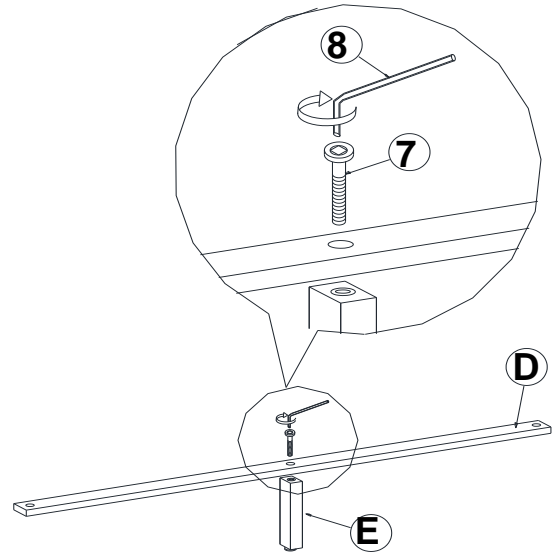

STEP 6

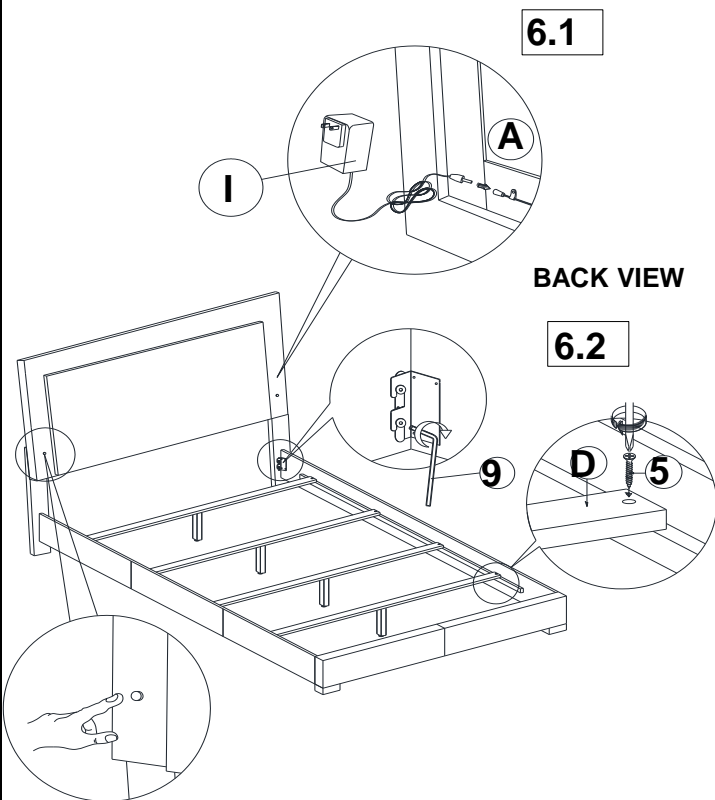

ON & OFF TOUCH SWITCH

STEP 7 COMPLETE

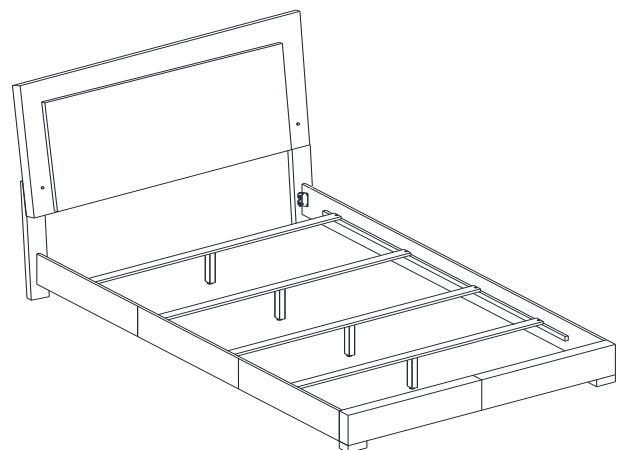

ITEM: 203500F (B1&B2)

Inner Size : 55.00W" X 76.00"D

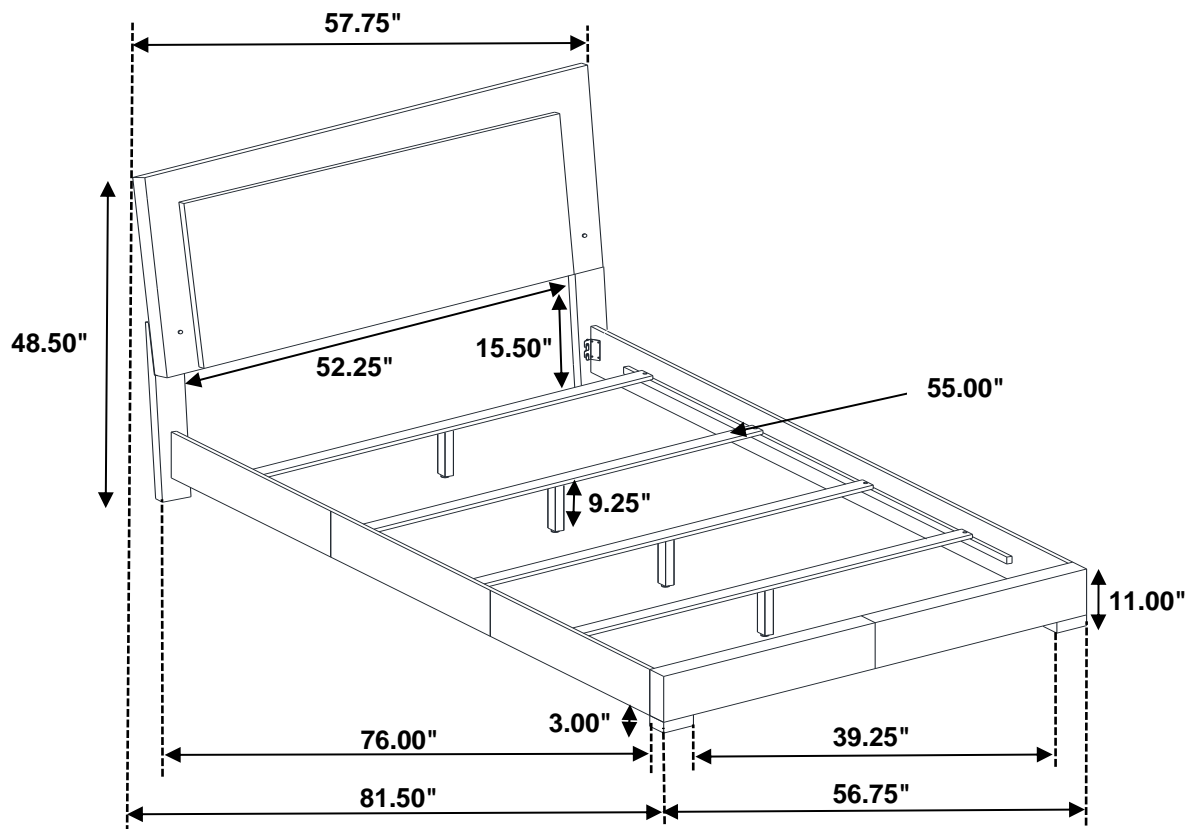

Note : Dimension tolerance $\pm 5\%$

ASSEMBLY INSTRUCTIONS
COASTER FINE FURNITURE

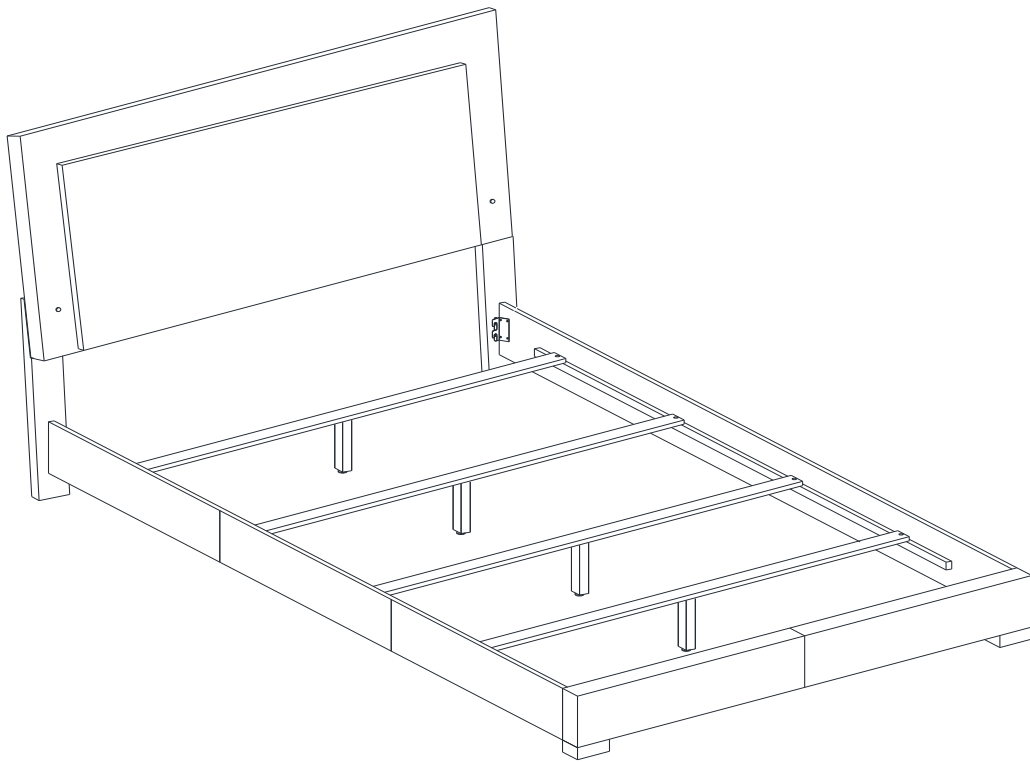

Fine Furniture for every stage of life

203500Q (B1&B2)
Queen Bed

ITEM: 203500Q (B1&B2)



ASSEMBLY INSTRUCTIONS

ASSEMBLY TIPS:

1. Remove hardware from box and sort by size.
2. Please check to see that all hardware and parts are present prior to start of assembly.
3. Please follow attached instructions in the same sequence as numbered to assure fast & easy assembly.



WARNING!

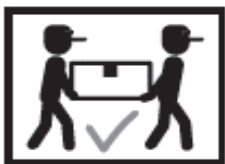

1. Don't attempt to repair or modify parts that are broken or defective. Please contact the store immediately.
2. This product is for home use only and not intended for commercial establishments.



ASSEMBLY TIME **20 MINUTES**





PARTS IDENTIFICATION



B1 (BOX 1)

- | | | | |
|----------|----------------------------|--|------------|
| A | HEADBOARD PANEL |  | 1PC |
| B | RIGHT HEADBOARD LEG |  | 1PC |

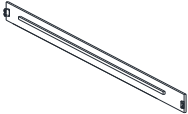
- | | | | |
|----------|---------------------------|---|------------|
| C | LEFT HEADBOARD LEG |  | 1PC |
|----------|---------------------------|---|------------|

B2 (BOX 2)

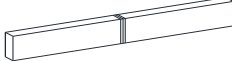
- | | | | |
|----------|--------------------------------------|---|-------------|
| D | BED SLAT |  | 4PCS |
| E | BED SLAT SUPPORT WITH LEVELER |  | 4PCS |
| F | BED RAIL |  | 2PCS |
| G | FOOTBOARD LEG |  | 2PCS |

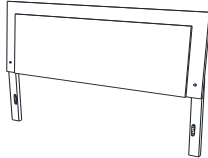
- | | | | |
|-----------|---|---|------------|
| H | FOOTBOARD PANEL |  | 1PC |
| I | ADAPTER PLUG |  | 1PC |
| HB | 203500Q (B1) FROM BOX 1 HEADBOARD COMPLETE |  | 1PC |

NOTE:

Phillips head screw driver is required in the assembly process; however, manufacturer does not provide this item.

ITEM: 203500Q (B1&B2)

ASSEMBLY INSTRUCTIONS

ASSEMBLY TIPS:

1. Remove hardware from box and sort by size.
2. Please check to see that all hardware and parts are present prior to start of assembly.
3. Please follow attached instructions in the same sequence as numbered to assure fast & easy assembly.







WARNING!



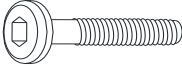

1. Don't attempt to repair or modify parts that are broken or defective. Please contact the store immediately.
2. This product is for home use only and not intended for commercial establishments.

HARDWARE IDENTIFICATION

Z-B1 (BOX 1) - HARDWARE PACK IS LOCATED IN 203500Q (B1)

1	BOLT (M4 x 30mm - BLK)		6PCS	3	FLAT WASHER (1/4" X 13mm - BLK)		6PCS
2	ALLEN WRENCH (M4 x 60mm - BLK)		1PC	4	LOCK WASHER (1/4" - BLK)		6PCS

Z-B2 (BOX 2) - HARDWARE PACK IS LOCATED IN 203500Q (B2)

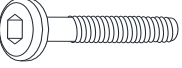
5	SHORT FLAT HEAD SCREW (M4 x 32mm - RBW)		8PCS	8	SMALL ALLEN WRENCH (M4 x 60MM - BLK)		1PC
6	LONG FLAT HEAD SCREW (M4 x 50mm - RBW)		6PCS	9	BIG ALLEN WRENCH (M5 x 65MM - BLK)		1PC
7	BOLT (M6 x 40mm - BLK)		4PCS				

NOTE:

Phillips head screw driver is required in the assembly process; however, manufacturer does not provide this item.

ASSEMBLY INSTRUCTIONS

STEP 1

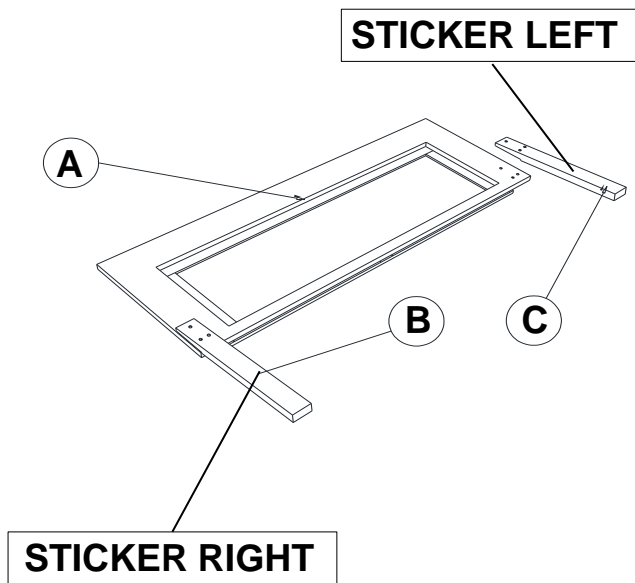

STEP 2

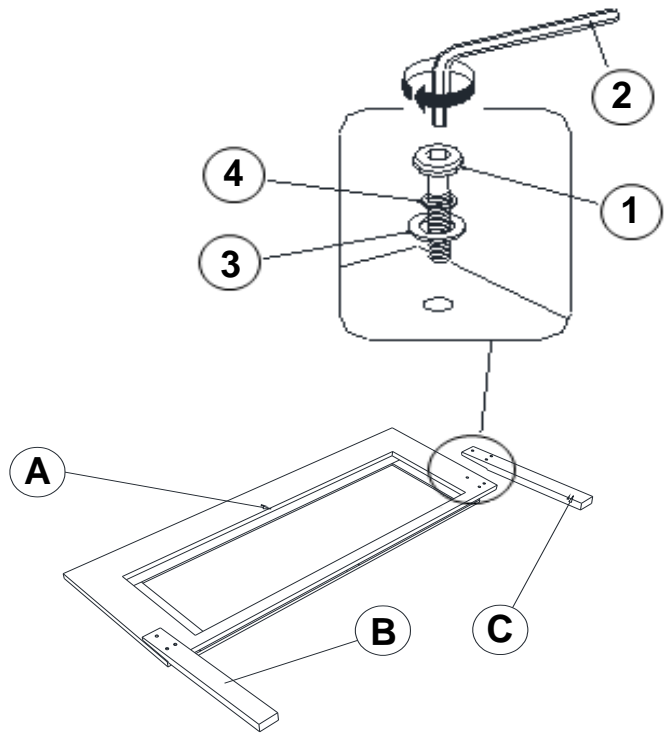

IF PURCHASE HEADBOARD ONLY, SKIP BELOW STEPS

STEP 3

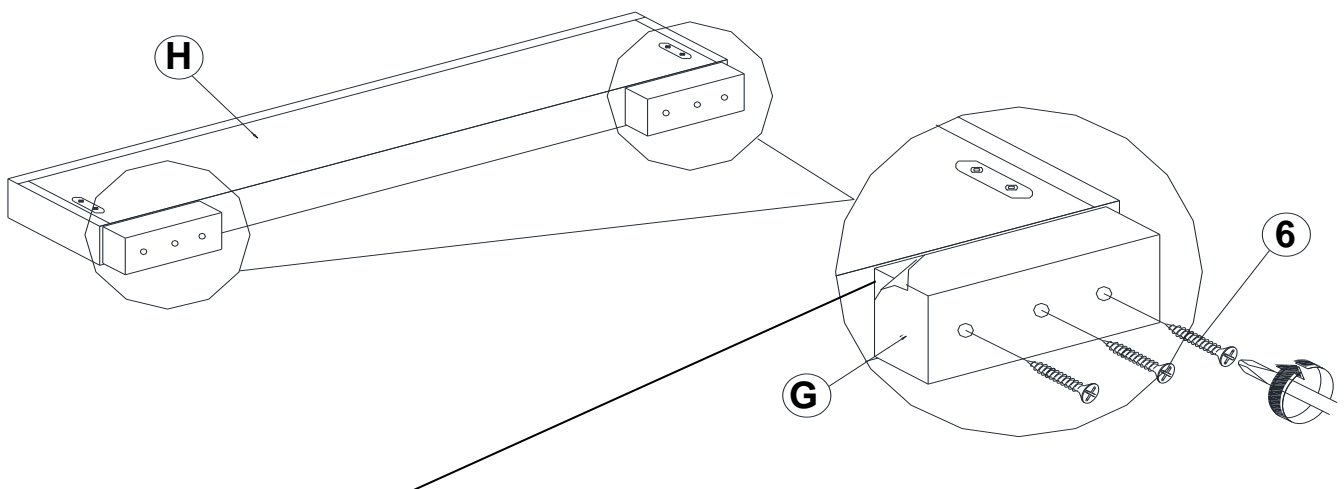

PLEASE REMOVE THE PROTECTIVE FILM BEFORE ASSEMBLY

ITEM: 203500Q (B1&B2)



ASSEMBLY INSTRUCTIONS

STEP 4

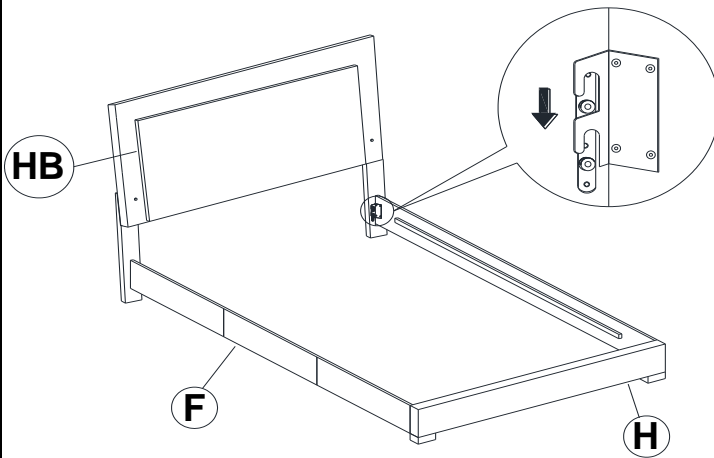

STEP 5

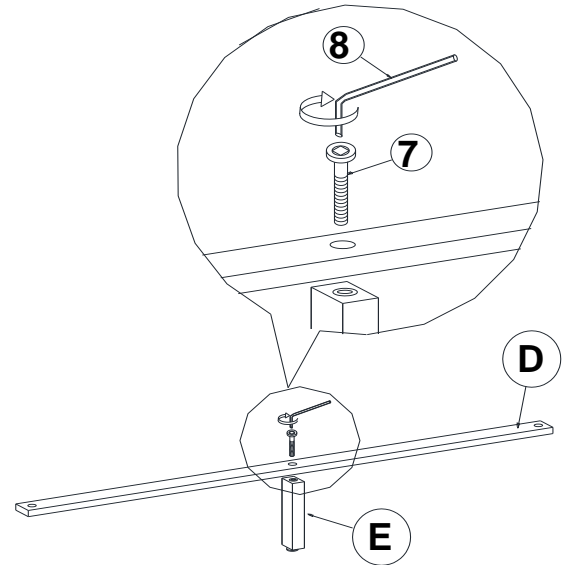

STEP 6

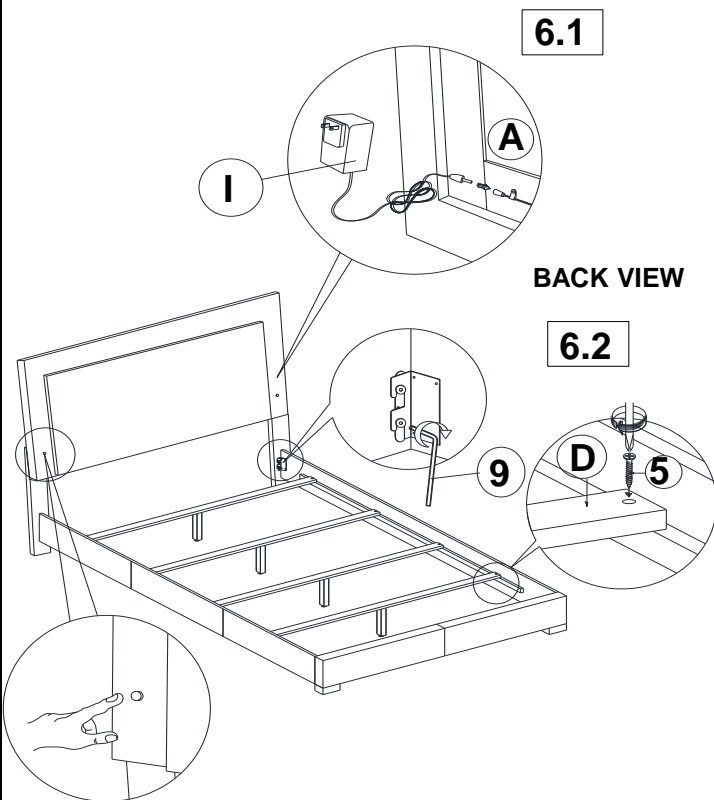

6.1

BACK VIEW

6.2

ON & OFF TOUCH SWITCH

STEP 7 COMPLETE

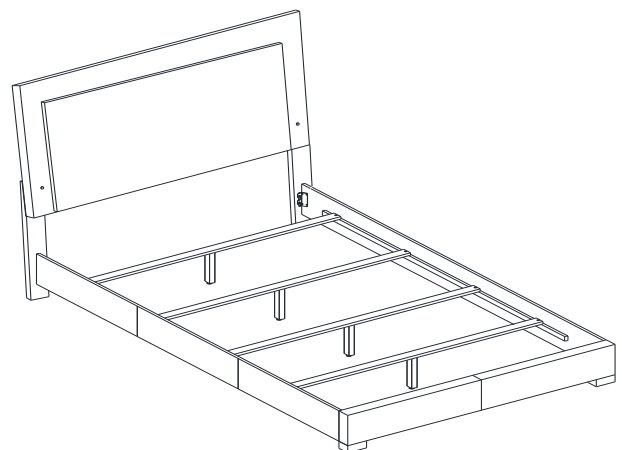

ITEM: 203500Q (B1&B2)



Inner Size : 61.00W" X 81.00"D

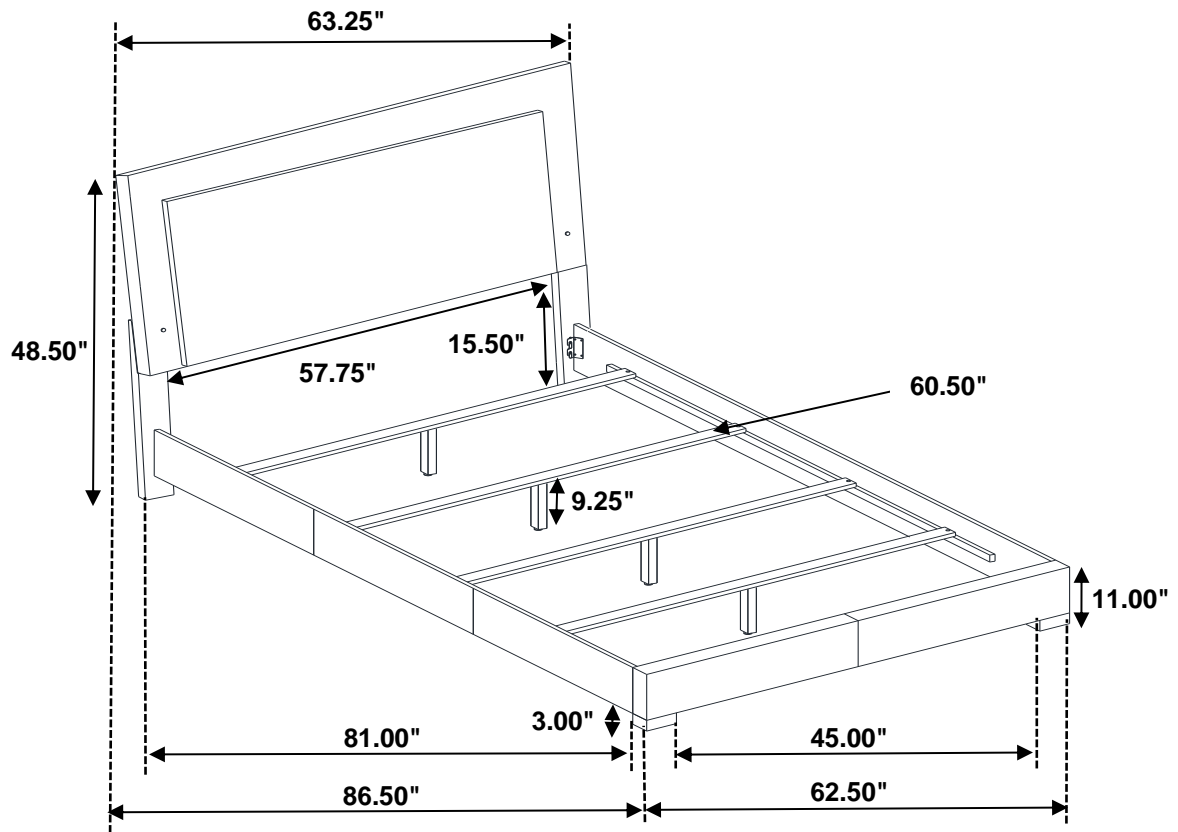

Note : Dimension tolerance \pm 5%

ASSEMBLY INSTRUCTIONS
COASTER FINE FURNITURE

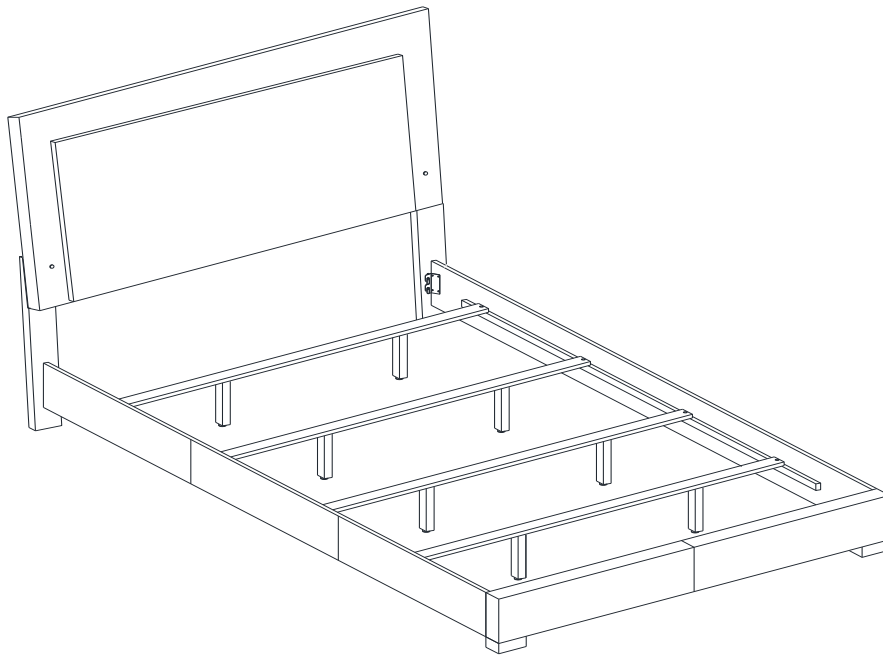

Fine Furniture for every stage of life

203500KE (B1&B2)
Eastern King Bed

ITEM: 203500KE (B1 & B2)



ASSEMBLY INSTRUCTIONS

ASSEMBLY TIPS:

1. Remove hardware from box and sort by size.
2. Please check to see that all hardware and parts are present prior to start of assembly.
3. Please follow attached instructions in the same sequence as numbered to assure fast & easy assembly.



WARNING!

1. Don't attempt to repair or modify parts that are broken or defective. Please contact the store immediately.
2. This product is for home use only and not intended for commercial establishments.



ASSEMBLY TIME

20 MINUTES

PARTS IDENTIFICATION

B1 (BOX 1)

A HEADBOARD PANEL  1PC

B RIGHT HEADBOARD LEG  1PC

C LEFT HEADBOARD LEG  1PC

B2 (BOX 2)

D BED SLAT  4PCS

E BED SLAT SUPPORT WITH LEVELER  8PCS

F BED RAIL  2PCS

G FOOTBOARD LEG  2PCS

H FOOTBOARD PANEL  1PC

I ADAPTER PLUG  1PC

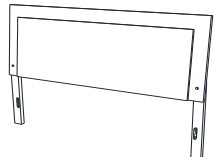
HB 203500KE (B1) FROM BOX 1 HEADBOARD COMPLETE  1PC

NOTE:

Phillips head screw driver is required in the assembly process; however, manufacturer does not provide this item.

ITEM: 203500KE (B1 & B2)

ASSEMBLY INSTRUCTIONS

ASSEMBLY TIPS:

1. Remove hardware from box and sort by size.
2. Please check to see that all hardware and parts are present prior to start of assembly.
3. Please follow attached instructions in the same sequence as numbered to assure fast & easy assembly.





WARNING!

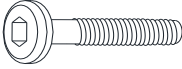

1. Don't attempt to repair or modify parts that are broken or defective. Please contact the store immediately.
2. This product is for home use only and not intended for commercial establishments.

HARDWARE IDENTIFICATION

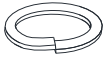
Z-B1 (BOX 1) - HARDWARE PACK IS LOCATED IN 203500KE (B1)

1	BOLT (M6 x 30mm - BLK)		6PCS	3	FLAT WASHER (1/4" X 13mm - BLK)		6PCS
2	ALLEN WRENCH (M4 x 60MM - BLK)		1PC	4	LOCK WASHER (1/4" - BLK)		6PCS

Z-B2 (BOX 2) - HARDWARE PACK IS LOCATED IN 203500KE (B2)

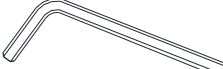
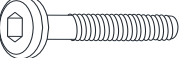
5	SHORT FLAT HEAD SCREW (M4 x 32mm - RBW)		8PCS	8	SMALL ALLEN WRENCH (M4 x 60MM - BLK)		1PC
6	LONG FLAT HEAD SCREW (M4 x 50mm - RBW)		6PCS	9	BIG ALLEN WRENCH (M5 x 65MM - BLK)		1PC
7	BOLT (M6 x 40mm - BLK)		8PCS				

NOTE:

Phillips head screw driver is required in the assembly process; however, manufacturer does not provide this item.

ASSEMBLY INSTRUCTIONS

STEP 1

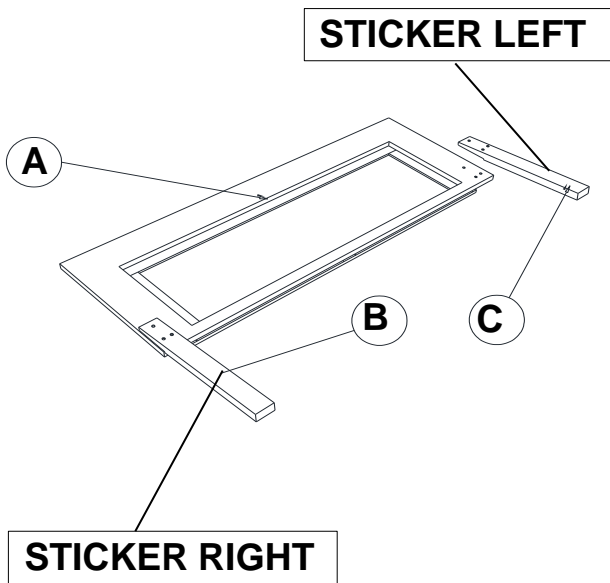

STEP 2

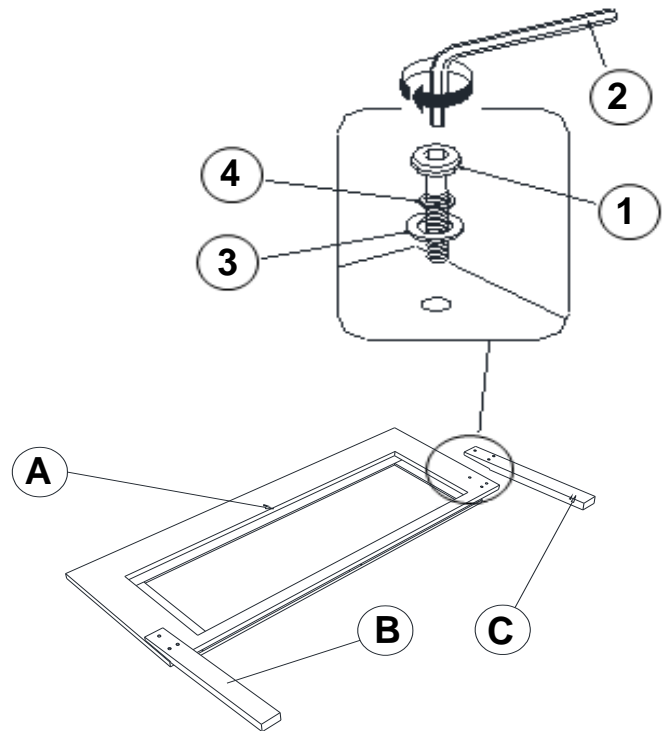

IF PURCHASE HEADBOARD ONLY, SKIP BELOW STEPS

STEP 3

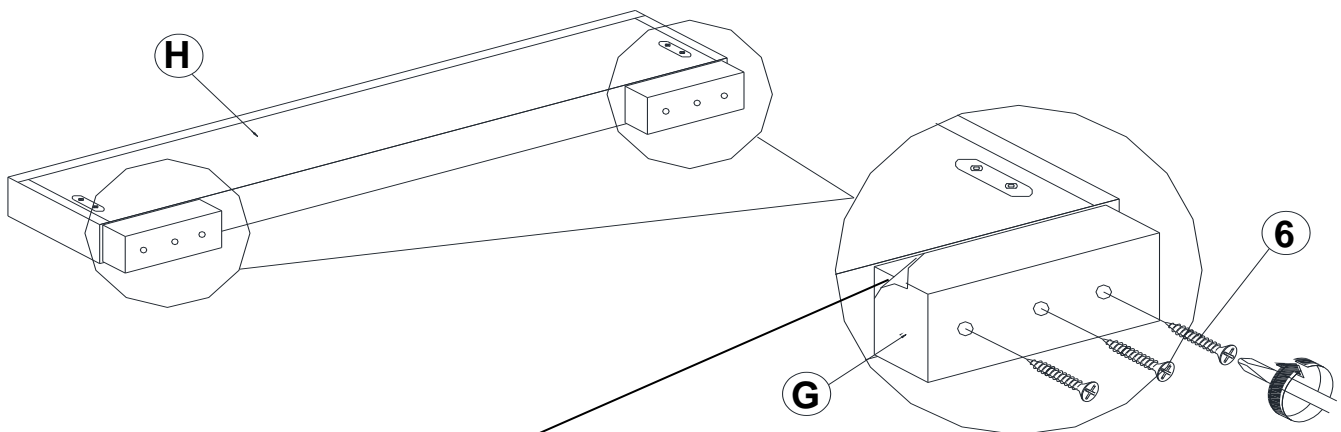

PLEASE REMOVE THE PROTECTIVE FILM BEFORE ASSEMBLY

ASSEMBLY INSTRUCTIONS

STEP 4

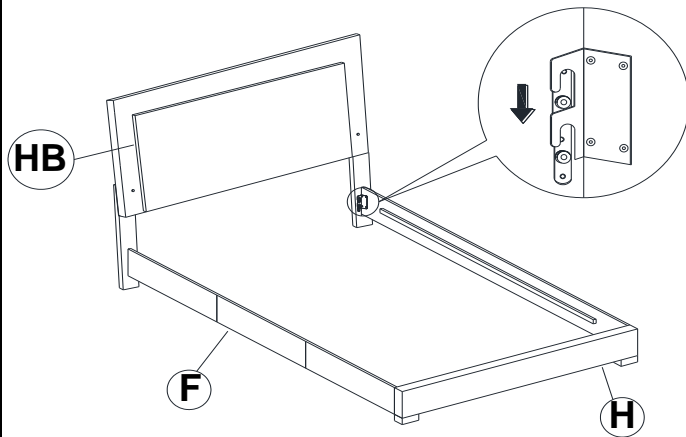

STEP 5

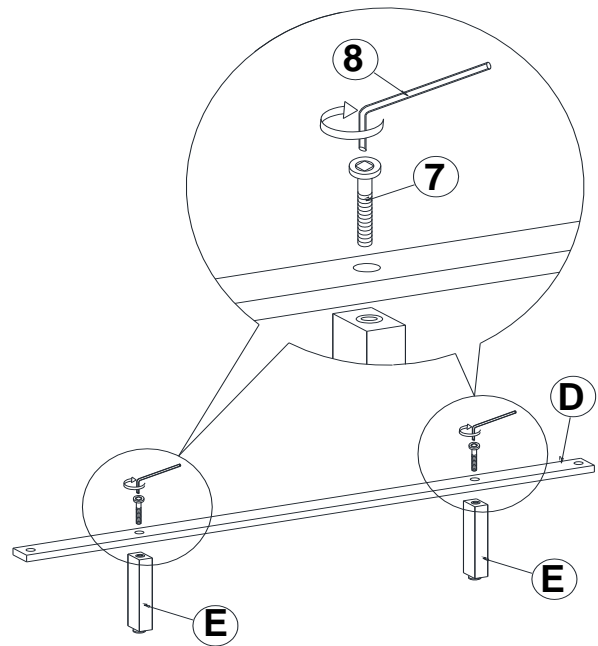

STEP 6

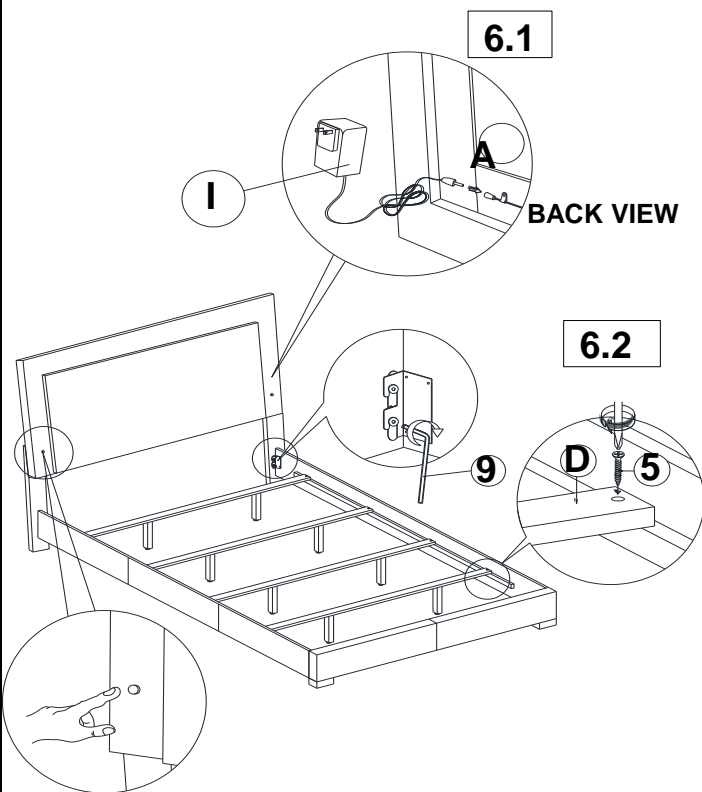

ON & OFF TOUCH SWITCH BUTTON

STEP 7 COMPLETE

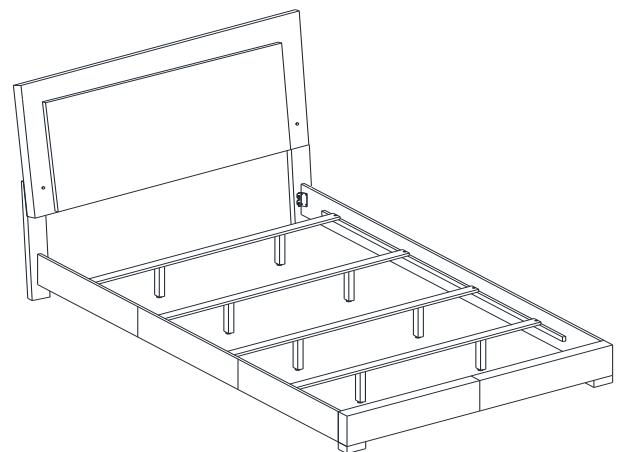

ITEM: 203500KE (B1&B2)



Inner Size : 76.75"W X 81.00"D

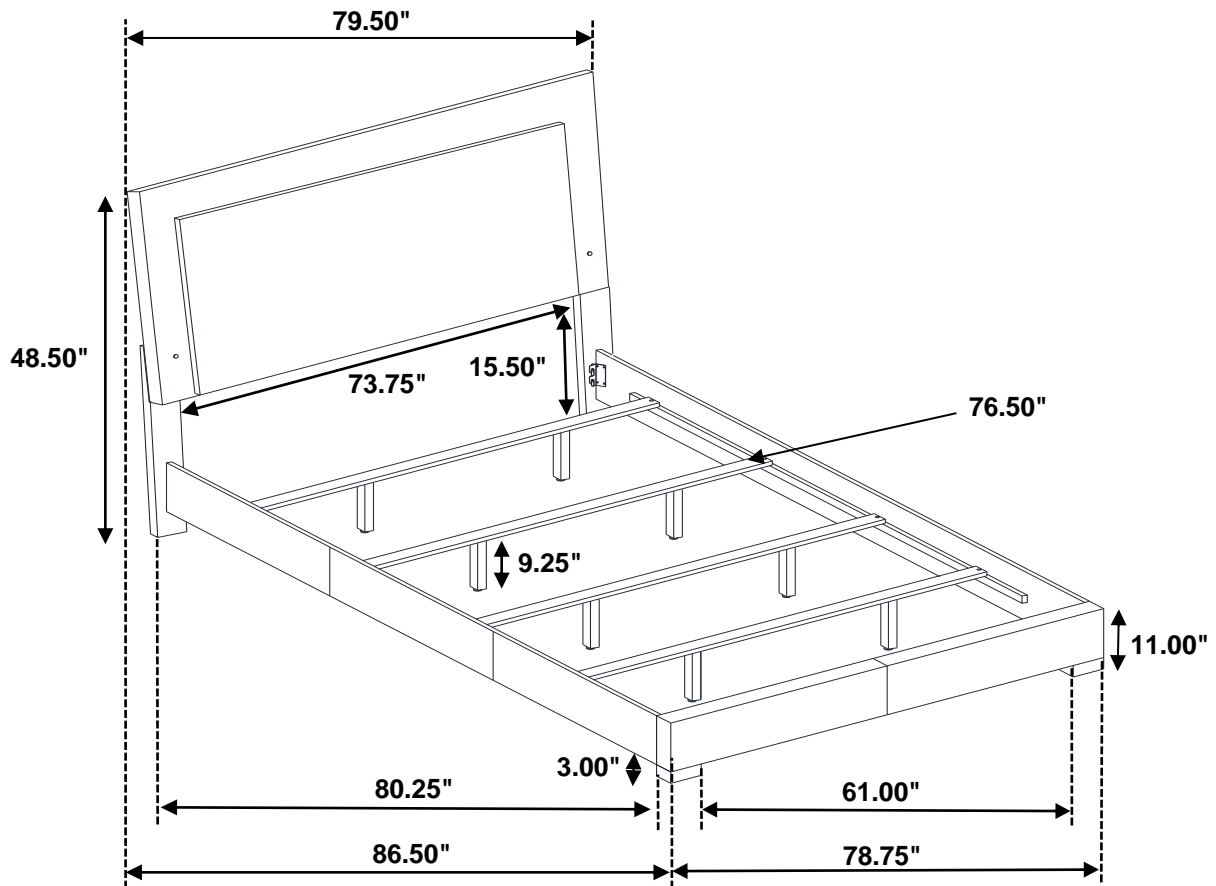

Note : Dimension tolerance $\pm 5\%$

ASSEMBLY INSTRUCTIONS
COASTER FINE FURNITURE



Fine Furniture for every stage of life

203502
Nightstand

ITEM: **203502**



ASSEMBLY INSTRUCTIONS

REMOVAL OF PROTECTIVE FILM

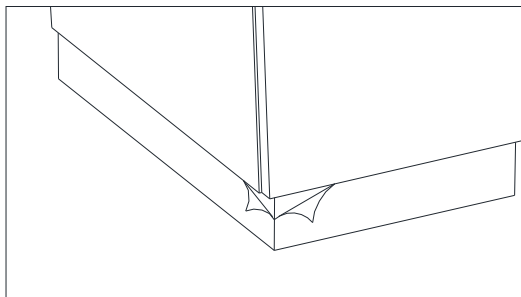
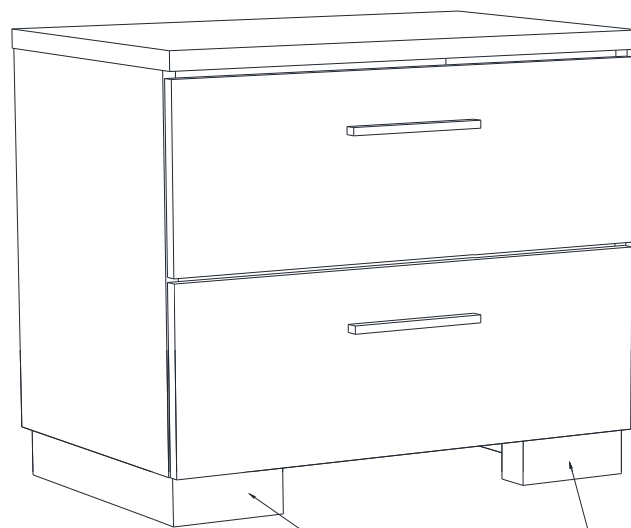

**PLEASE REMOVE THE
PROTECTIVE FILM
BEFORE USE**



ITEM:203502



Inner Size of Drawer : 20.00"W x 12.50"D x 5.00"H x 0.25"T

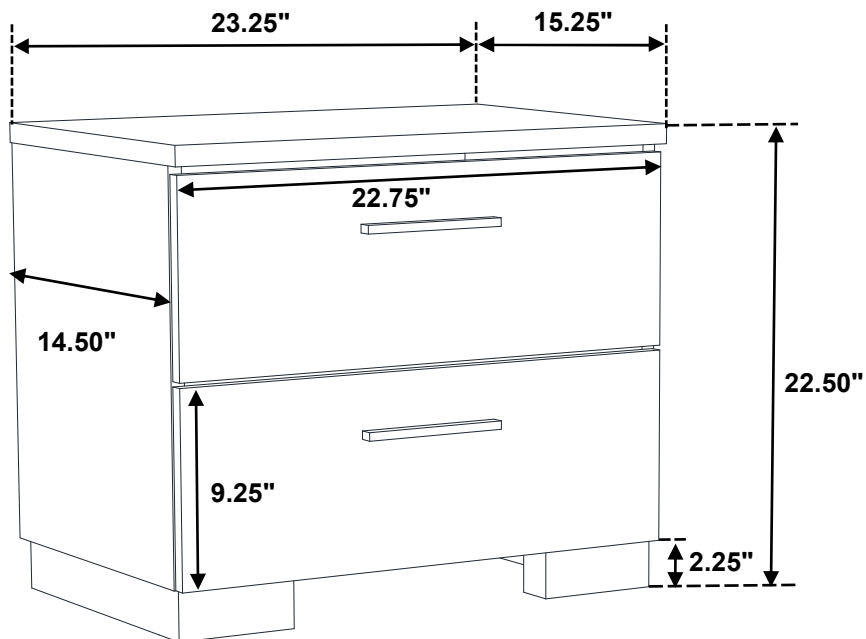

Note : Dimension tolerance $\pm 5\%$

ASSEMBLY INSTRUCTIONS
COASTER FINE FURNITURE



Fine Furniture for every stage of life

203503
Dresser

ITEM: **203503**

ASSEMBLY INSTRUCTIONS



REMOVAL OF PROTECTIVE FILM

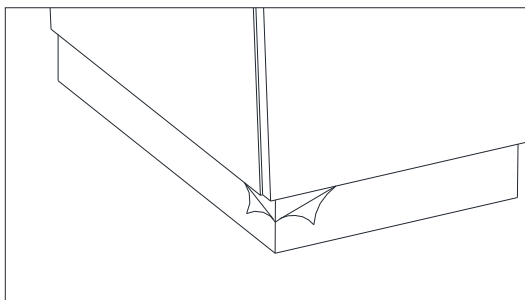

**PLEASE REMOVE THE
PROTECTIVE FILM
BEFORE USE**



ITEM:203503



Inner Size of Drawer : 28.75"W x 12.50"D x 5.00"H x 0.25"T

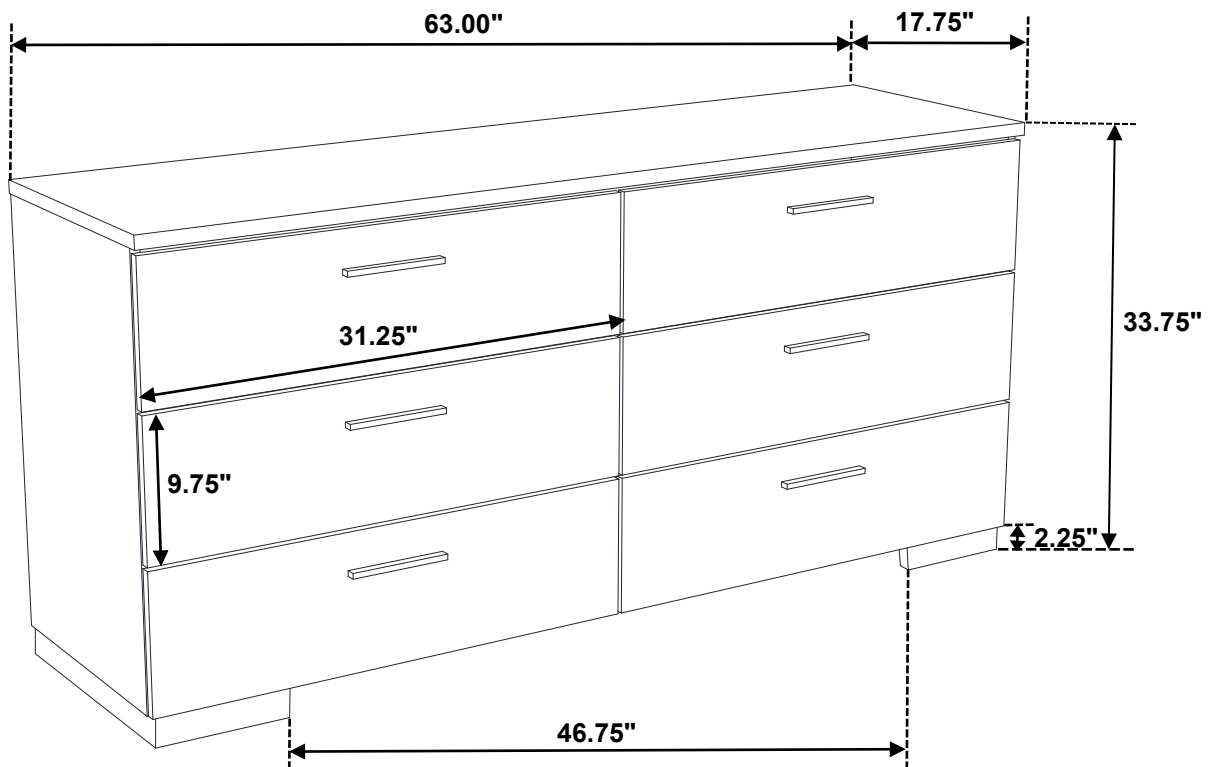

Note : Dimension tolerance \pm 5%

ASSEMBLY INSTRUCTIONS
COASTER FINE FURNITURE

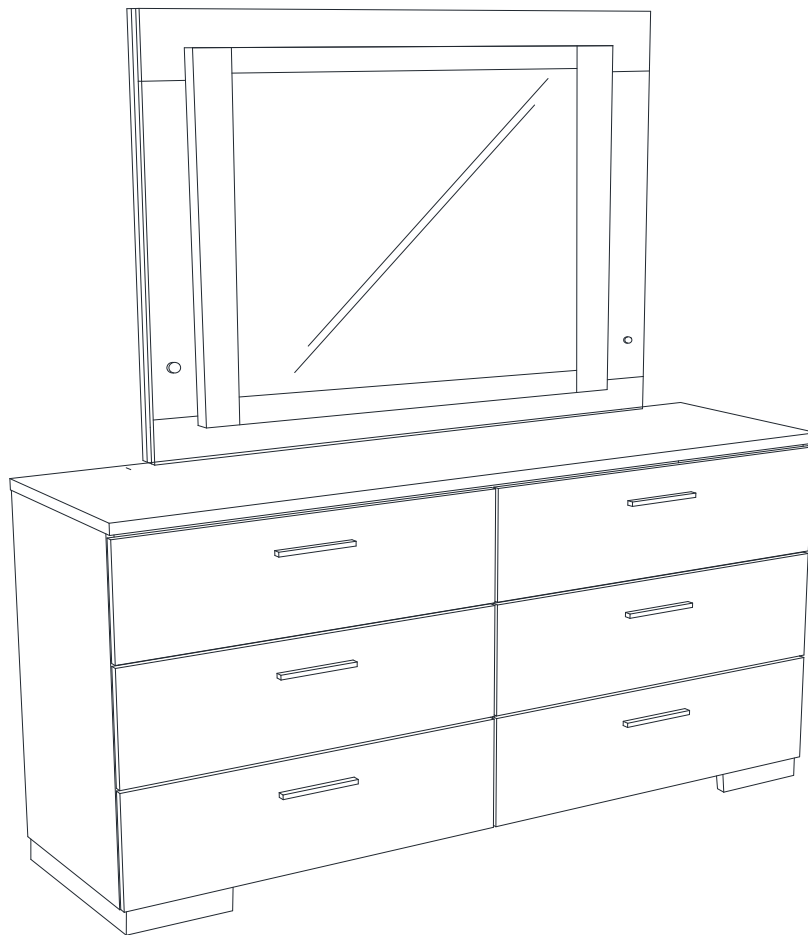

Fine Furniture for every stage of life

203504LED
LED Mirror

ITEM: 203504LED



ASSEMBLY INSTRUCTIONS

ASSEMBLY TIPS:

1. Remove hardware from box and sort by size.
2. Please check to see that all hardware and parts are present prior to start of assembly.
3. Please follow attached instructions in the same sequence as numbered to assure fast & easy assembly.



WARNING!

1. Don't attempt to repair or modify parts that are broken or defective. Please contact the store immediately.
2. This product is for home use only and not intended for commercial establishments.



ASSEMBLY TIME

10 MINUTES

PARTS IDENTIFICATION

A MIRROR 1PC

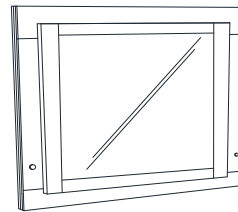

B DRESSER FROM BOX ITEM # 203503 1PC



C MIRROR SUPPORT (PACK WITH DRESSER) 2PCS

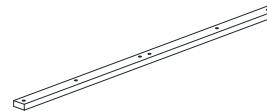

D ADAPTER PLUG 1PC



HARDWARE IDENTIFICATION

1 FLAT HEAD SCREW (M4 x 32mm - RBW) 10PCS



NOTE:

Phillips head screw driver is required in the assembly process; however, manufacturer does not provide this item.

ITEM: **203504LED**



ASSEMBLY INSTRUCTIONS

STEP 1

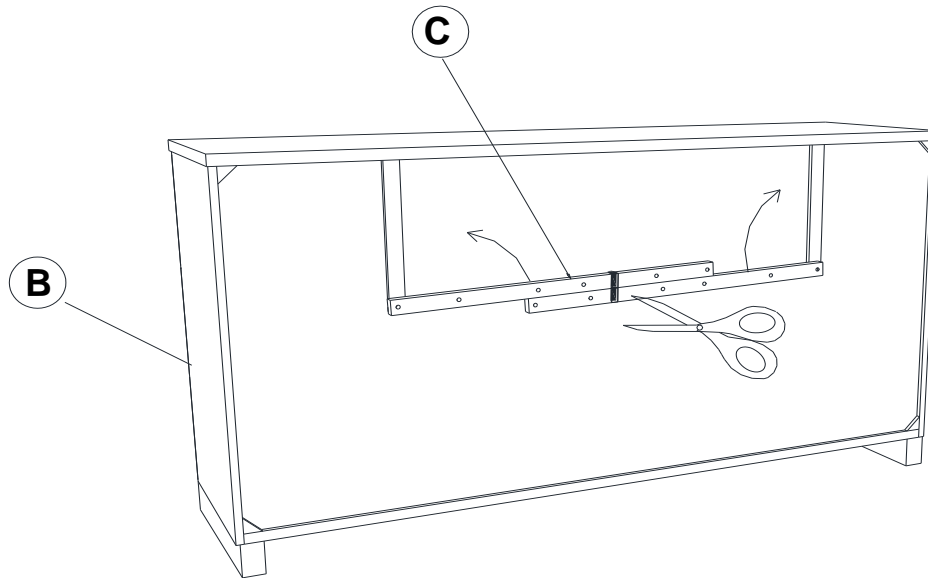

STEP 2

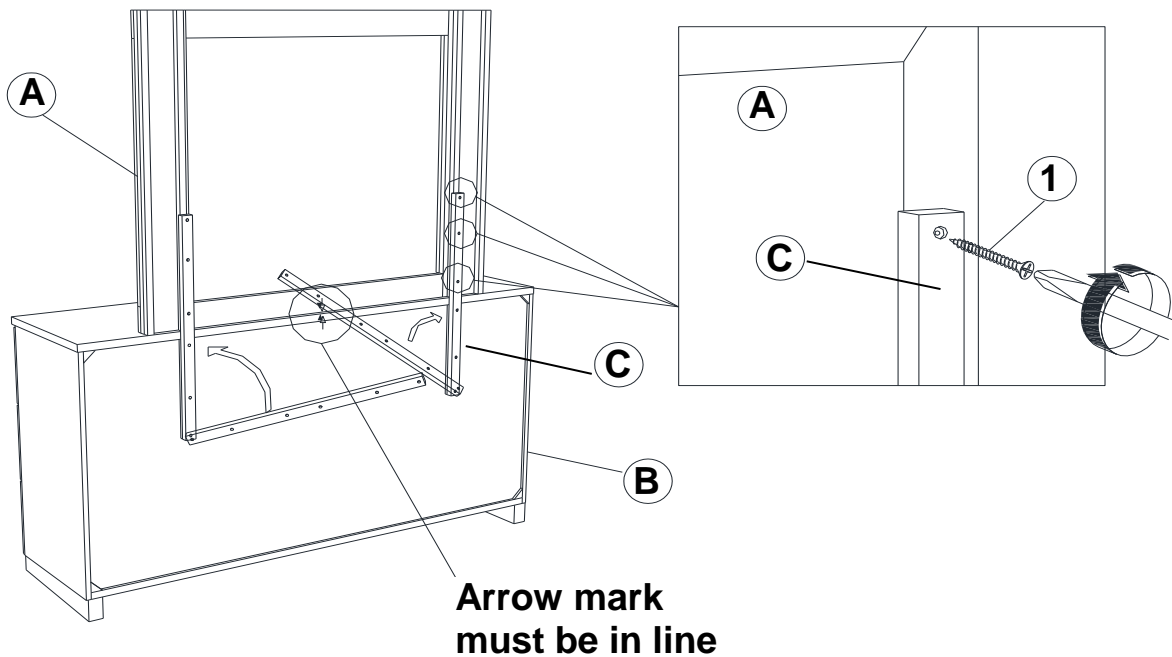

**BACK VIEW

ITEM: **203504LED**



ASSEMBLY INSTRUCTIONS

STEP 3

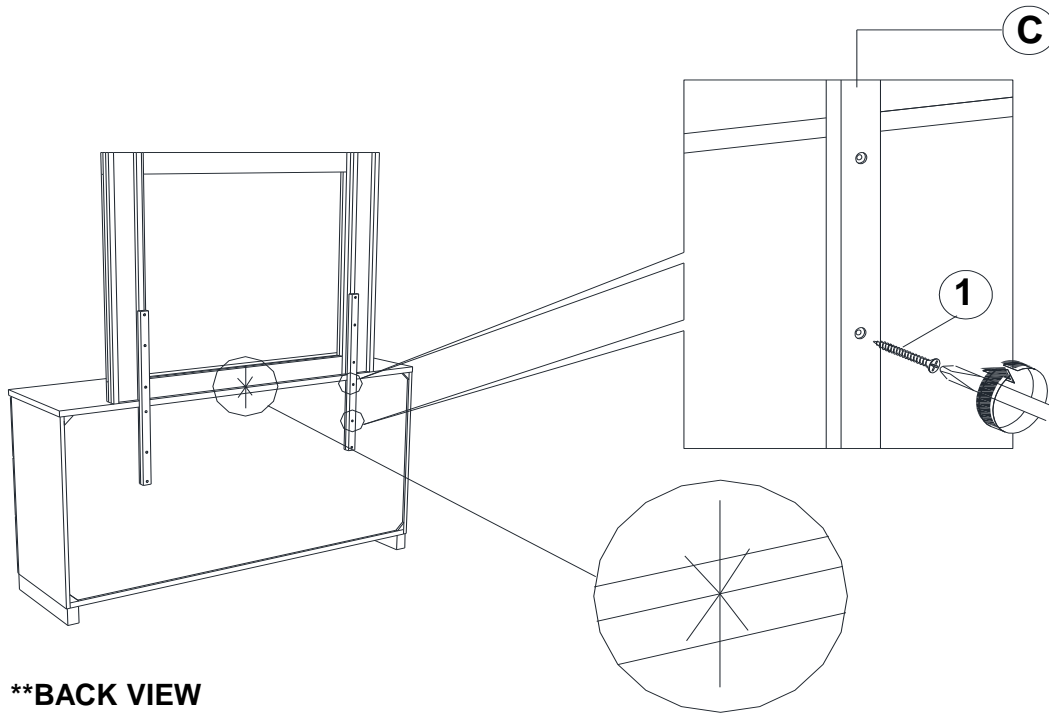

****BACK VIEW**

Arrow Marking Must Be Aligned

STEP 4

COMPLETE

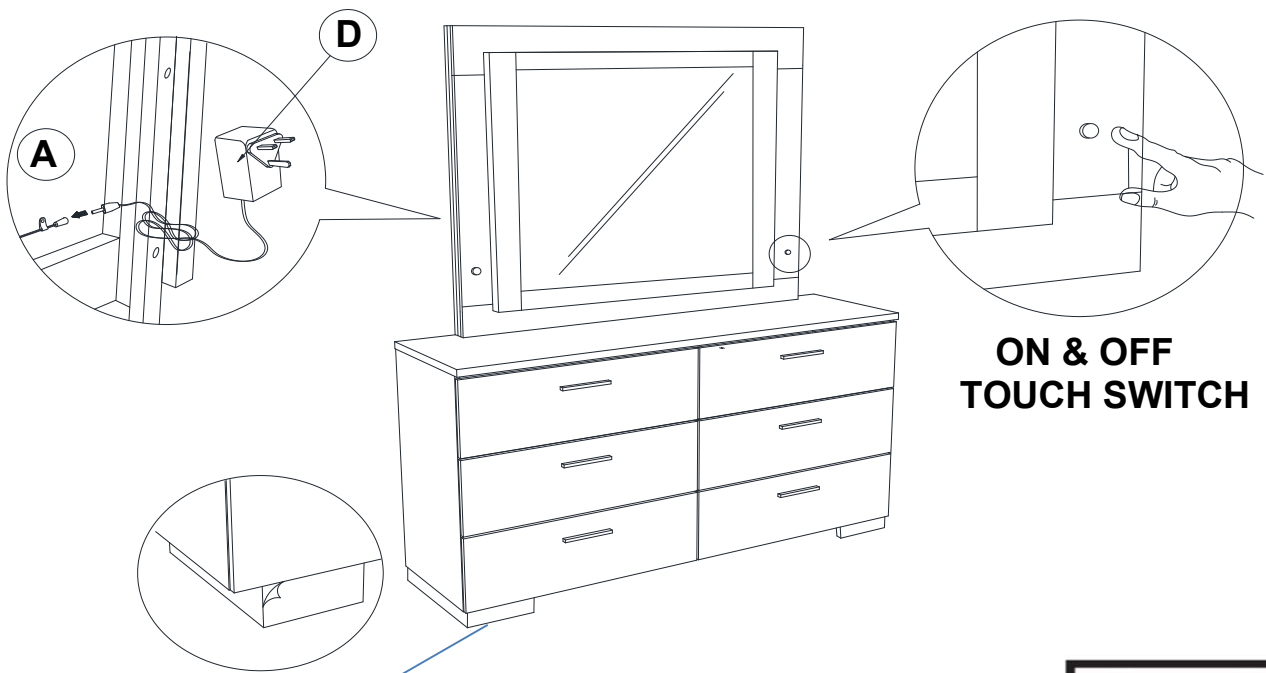

PLEASE REMOVE THE PROTECTIVE FILM BEFORE USE

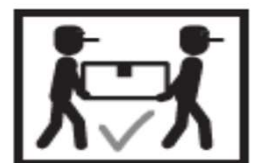

ITEM: 203504LED

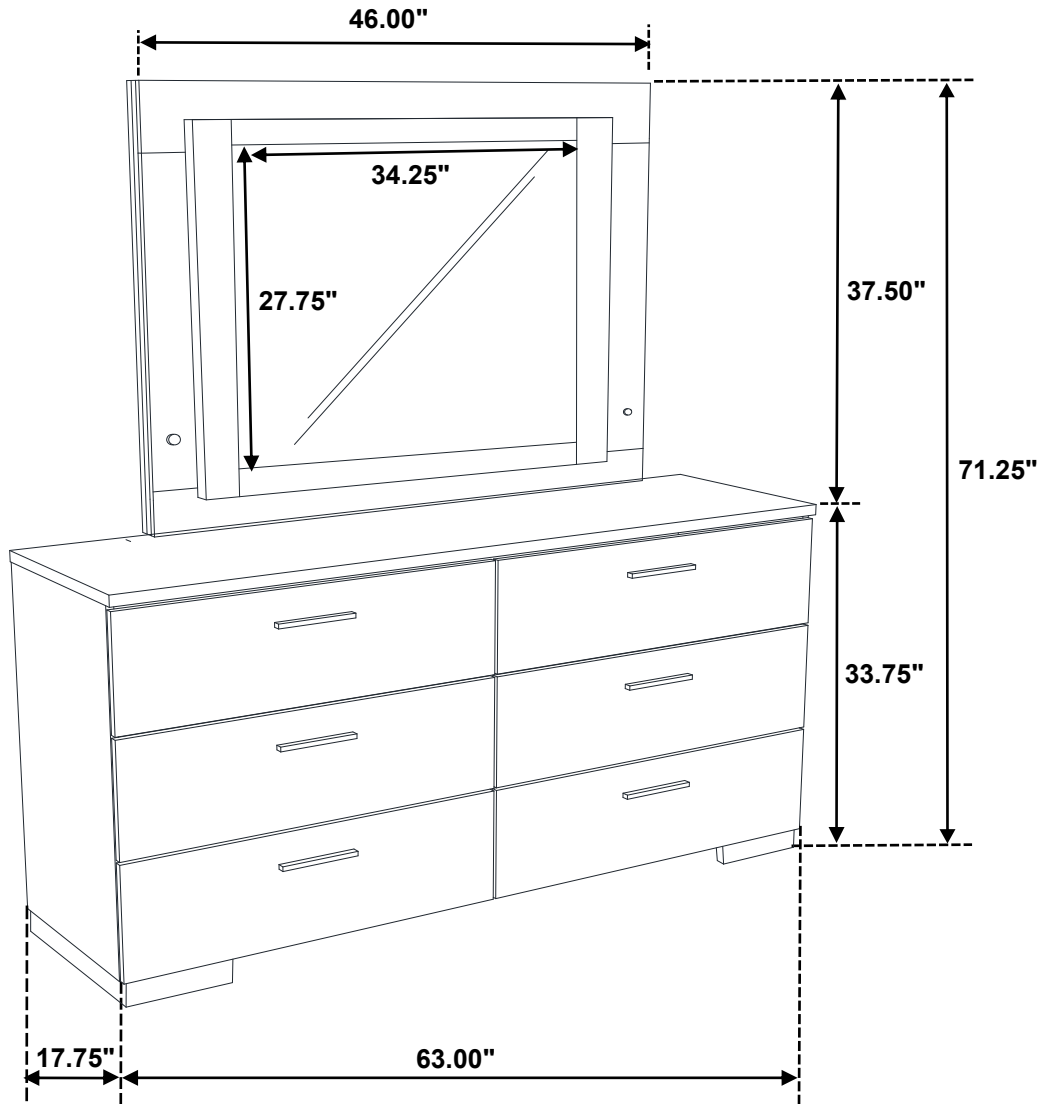

Note : Dimension tolerance $\pm 5\%$

ASSEMBLY INSTRUCTIONS
COASTER FINE FURNITURE



Fine Furniture for every stage of life

203505
Chest

ITEM: **203505**

ASSEMBLY INSTRUCTIONS



REMOVAL OF PROTECTIVE FILM

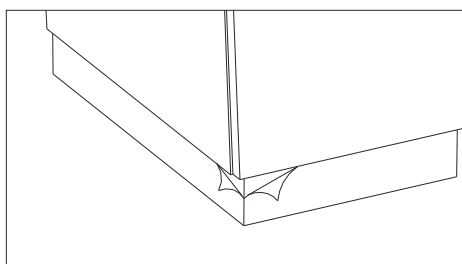

**PLEASE REMOVE THE
PROTECTIVE FILM
BEFORE USE**



ITEM:203505



Inner Size of Drawer : 32.00"W x 12.50"D x 5.00"H x 0.25"T

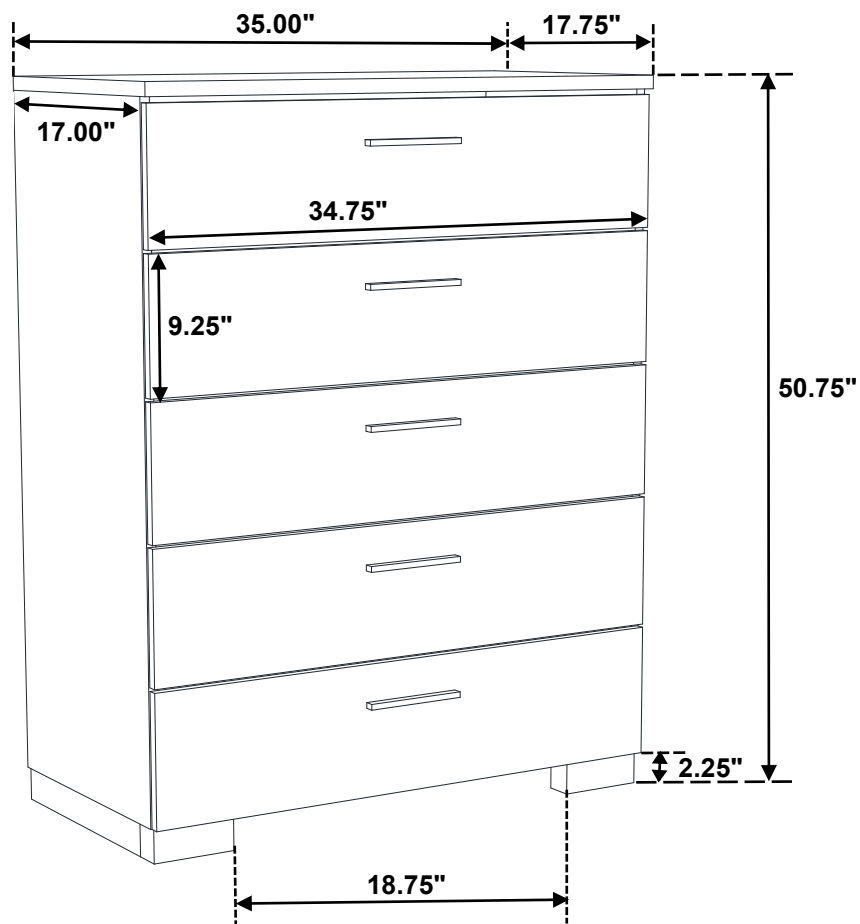

Note : Dimension tolerance $\pm 5\%$

ASSEMBLY INSTRUCTIONS
COASTER FINE FURNITURE



Fine Furniture for every stage of life

203507(B1&B2)
Vanity Mirror & Desk

ITEM: 203507(B1&B2)



ASSEMBLY INSTRUCTIONS

ASSEMBLY TIPS:

1. Remove hardware from box and sort by size.
2. Please check to see that all hardware and parts are present prior to start of assembly.
3. Please follow attached instructions in the same sequence as numbered to assure fast & easy assembly.



WARNING!

1. Don't attempt to repair or modify parts that are broken or defective. Please contact the store immediately.
2. This product is for home use only and not intended for commercial establishments.



ASSEMBLY TIME

10 MINUTES

PARTS IDENTIFICATION

B1 (BOX 1)

A MIRROR

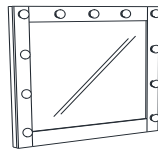

1PC

C ADAPTOR



1PC

B MIRROR
SUPPORT



2PCS

B2 (BOX 2)

D DESKTOP

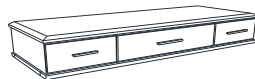

1PC

F COMPARTMENT



2PCS

E BACK PANEL



1PC

HARDWARE IDENTIFICATION

Z-B1 (BOX 1) - HARDWARE PACK IS LOCATED IN 203507 (B1)

LONG FLAT HEAD
1 SCREW
(M4 x 32mm - RBW)



8PCS

Z-B2 (BOX 2) - HARDWARE PACK IS LOCATED IN 203507 (B2)

2 ALLEN WRENCH
(M4 x 60MM - BLK)



1PC

3 SHORT FLAT
HEAD SCREW
(M4 x 25mm - RBW)



11PCS

4 BOLT
(M6 x 30mm - BLK)

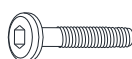

2PCS

5 LOCK WASHER
(1/4" - BLK)



2PCS

6 FLAT WASHER
(1/4" X 19mm - BLK)



2PCS

7 WOOD DOWEL
(M6 x 20mm)



4PCS

ITEM: **203507(B1&B2)**

ASSEMBLY INSTRUCTIONS

STEP 1

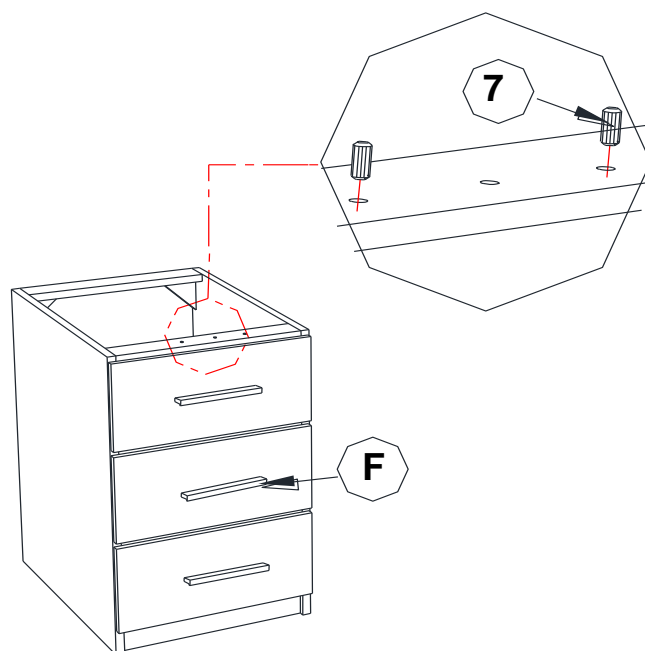

STEP 2

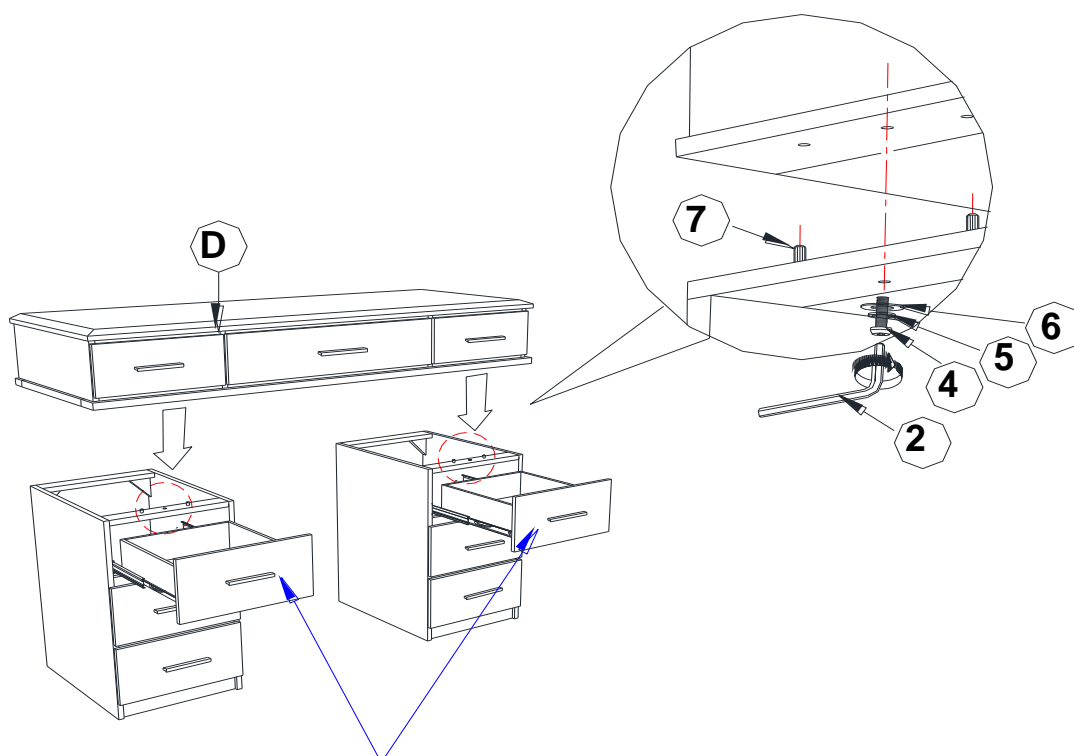

REMARK : Pull out drawer for easy assembly process

ITEM: **203507(B1&B2)**



ASSEMBLY INSTRUCTIONS

STEP 3

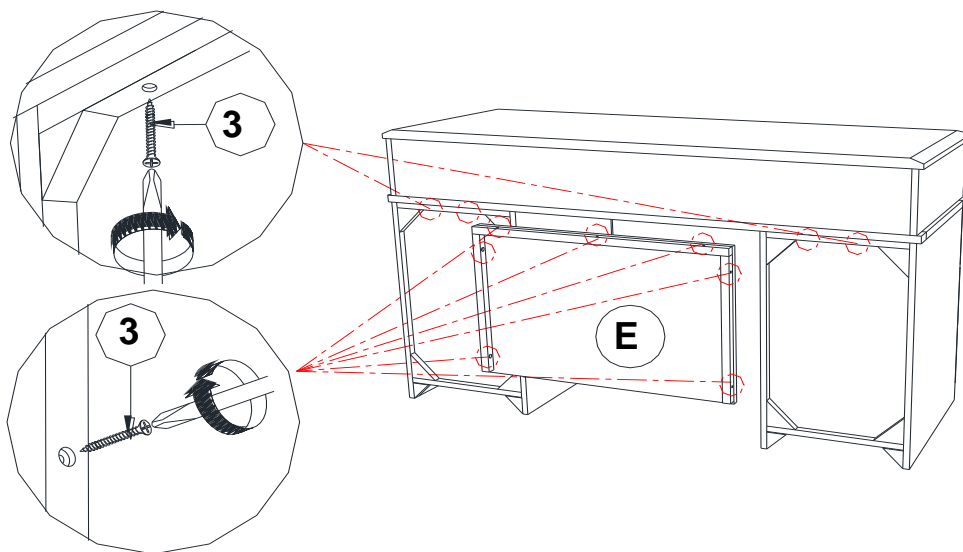

STEP 4
COMPLETE



ITEM: 203507(B1&B2)

ASSEMBLY INSTRUCTIONS

STEP 5

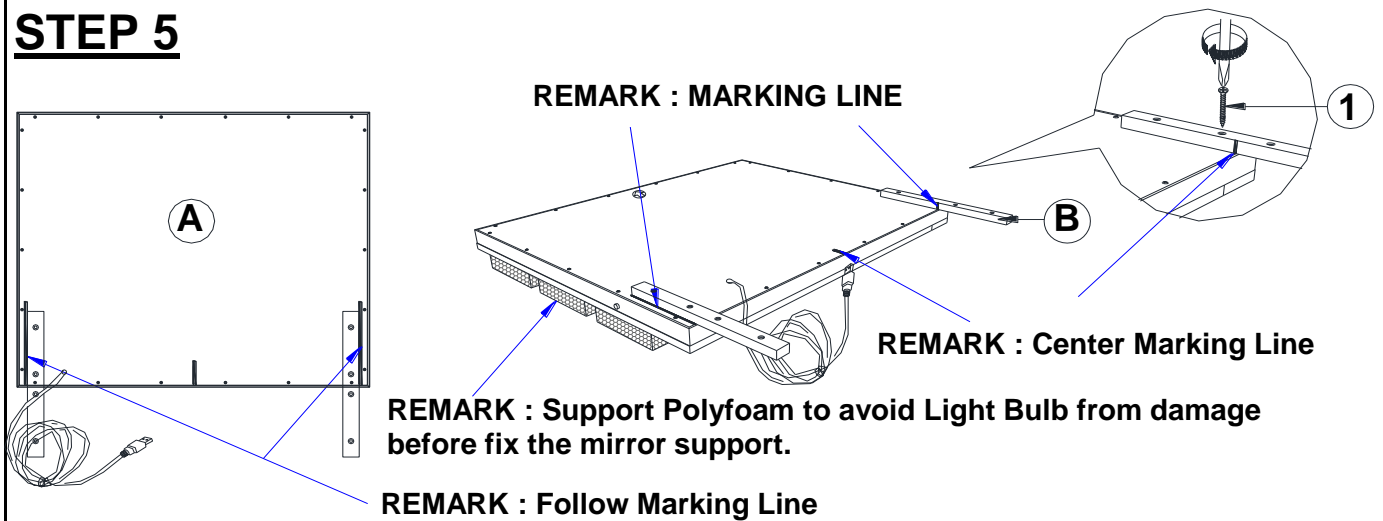

STEP 6

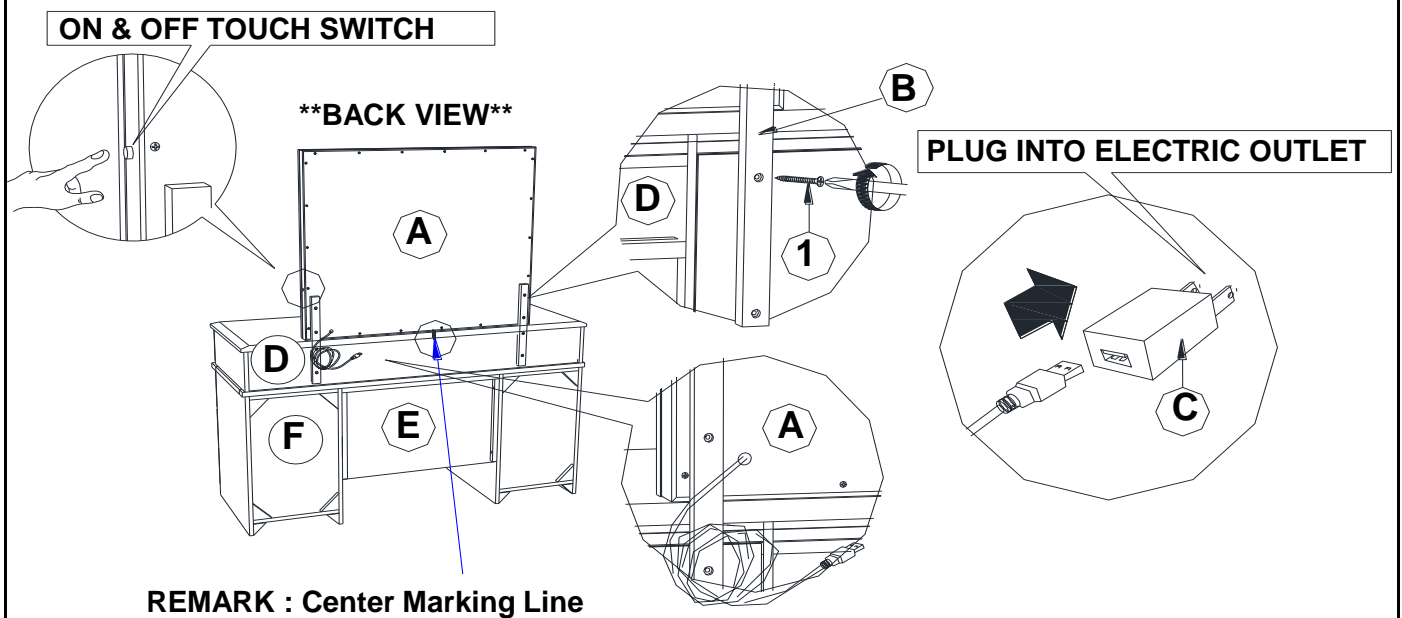

STEP 7 COMPLETE

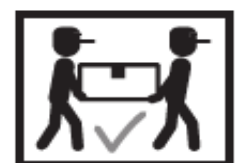
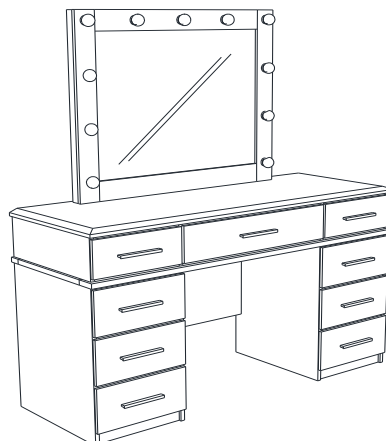

ITEM: 203507(B1&B2)



Inner Size of Drawer (Top Center) : 23.25"W X 12.50"D X 3.00"H X 0.25"T
Inner Size of Drawer (Others) : 12.50"W X 11.25"D X 3.00"H X 0.25"T

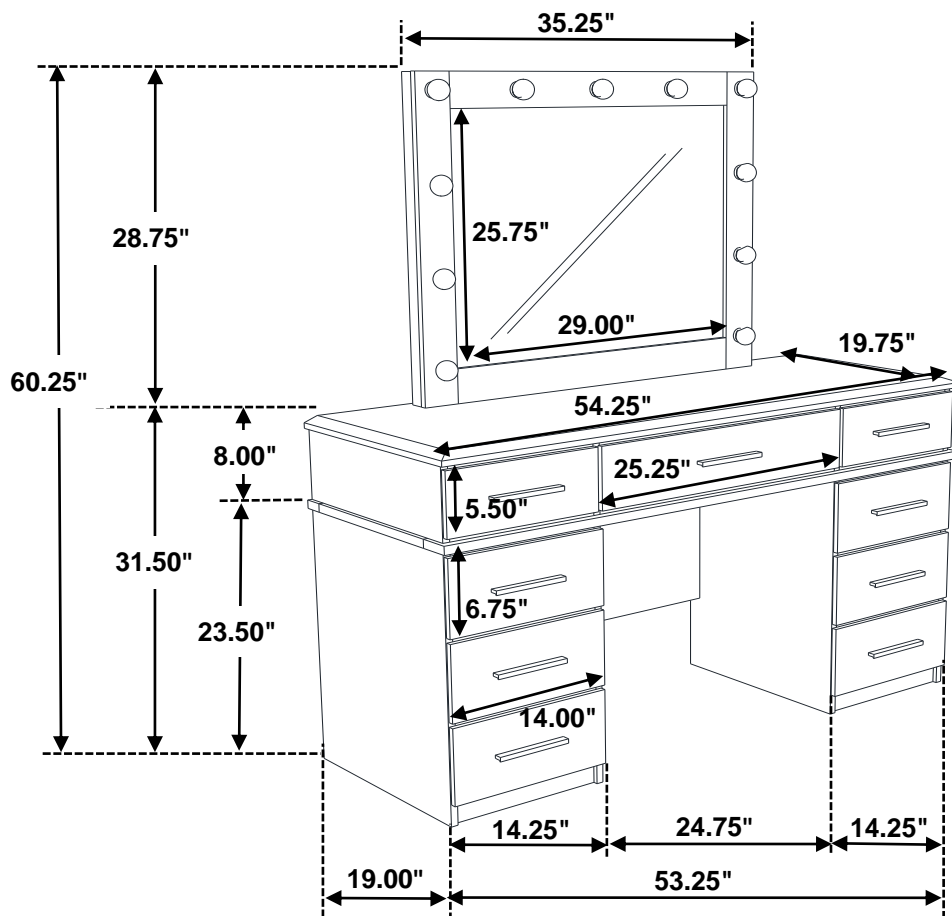

Note : Dimension tolerance $\pm 5\%$

ASSEMBLY INSTRUCTIONS
COASTER FINE FURNITURE



Fine Furniture for every stage of life

203507STL
Stool

ITEM: 203507STL



ASSEMBLY INSTRUCTIONS

ASSEMBLY TIPS:

1. Remove hardware from box and sort by size.
2. Please check to see that all hardware and parts are present prior to start of assembly.
3. Please follow attached instructions in the same sequence as numbered to assure fast & easy assembly.



WARNING!

1. Don't attempt to repair or modify parts that are broken or defective. Please contact the store immediately.
2. This product is for home use only and not intended for commercial establishments.



ASSEMBLY TIME

10 MINUTES

PARTS IDENTIFICATION

A SEAT

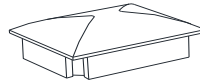

1PC

B LEG



4PCS

HARDWARE IDENTIFICATION

1 ALLEN WRENCH
(M4 x 60MM - BLK)



1PC

2 BOLT
(M6 x 50mm - BLK)

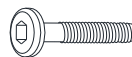

8PCS

3 LOCK WASHER
(1/4" - BLK)



8PCS

4 FLAT WASHER
(1/4" X 19mm - BLK)



8PCS

ITEM: **203507STL**



ASSEMBLY INSTRUCTIONS

STEP 1

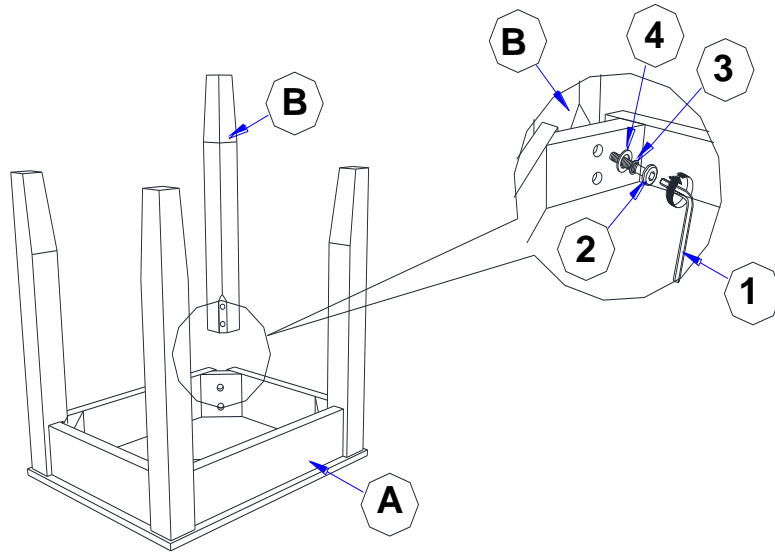

STEP 2
COMPLETE

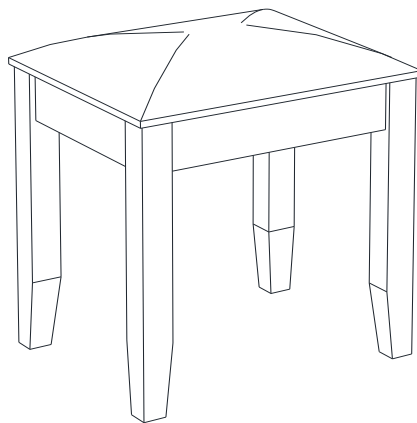

ITEM: **203507STL**

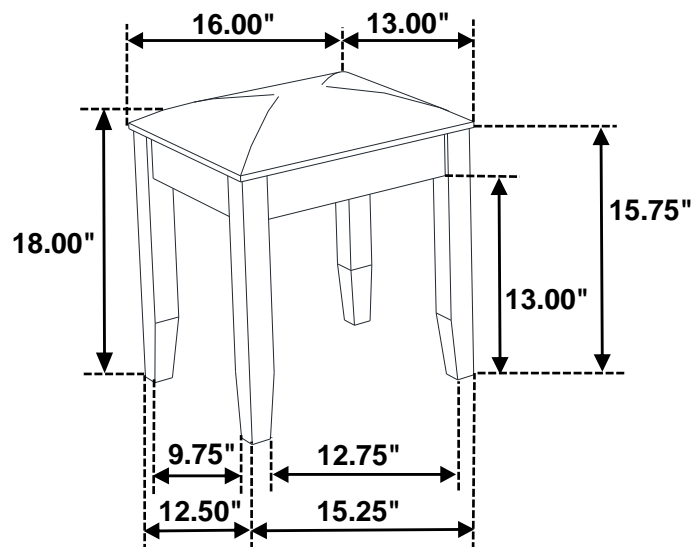

Note : Dimension tolerance \pm 5%