

ASSEMBLY INSTRUCTIONS
COASTER FINE FURNITURE



Fine Furniture for every stage of life

206101Q (B1-B3)
Queen Bed

ITEM: 206101Q (B1-B3)



ASSEMBLY INSTRUCTIONS

ASSEMBLY TIPS:

1. Remove hardware from box and sort by size.
2. Please check to see that all hardware and parts are present prior to start of assembly.
3. Please follow attached instructions in the same sequence as numbered to assure fast & easy assembly.



WARNING!

1. Don't attempt to repair or modify parts that are broken or defective. Please contact the store immediately.
2. This product is for home use only and not intended for commercial establishments.



ASSEMBLY TIME

40 MINUTES

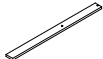

PARTS IDENTIFICATION

B1 (BOX 1)

A	HEADBOARD		1PC
B	HEADBOARD SUPPORT LEG		2PCS







C	HEADBOARD PANEL		1PC
---	-----------------	---	-----





B2 (BOX 2)

D	RIGHT EAR PANEL		1PC
E	LEFT EAR PANEL		1PC

F	EAR PANEL SUPPORT		2PCS
---	-------------------	---	------

B3 (BOX 3)

G	FOOTBOARD		1PC
H	LEFT BED RAIL		1PC
I	RIGHT BED RAIL		1PC
J	BED SLAT		10PCS
K	BED SLAT WITH HOLES		3PCS
L	BED SLAT SUPPORT		6PCS

MV	FOOTBOARD LEG		2PCS
N	CENTER RAIL		2PCS
O	CENTER RAIL SUPPORT		2PCS
HB	206101Q (B1) FROM BOX 1 HEADBOARD COMPLETE		1PC
ER	206101Q (B2) FROM BOX 2 LEFT AND RIGHT EAR PANEL COMPLETE		2PCS

NOTE:

Phillips head screw driver is required in the assembly process; however, manufacturer does not provide this item.

ITEM: 206101Q (B1-B3)



ASSEMBLY INSTRUCTIONS

ASSEMBLY TIPS:

1. Remove hardware from box and sort by size.
2. Please check to see that all hardware and parts are present prior to start of assembly.
3. Please follow attached instructions in the same sequence as numbered to assure fast & easy assembly.



WARNING!

1. Don't attempt to repair or modify parts that are broken or defective. Please contact the store immediately.
2. This product is for home use only and not intended for commercial establishments.

HARDWARE IDENTIFICATION

Z-B3 (BOX 3) - HARDWARE PACK IS LOCATED IN 206101Q (B3)

1	ALLEN WRENCH (4MM - RBW)		1PC	7	MEDIUM PAN HEAD SCREW (#4 x 25mm - RBW)		4PCS
2	BOLT 1 (Ø1/4" x 30mm - RBW)		4PCS	8	LONG PAN HEAD SCREW (#4 x 38mm - RBW)		32PCS
3	BOLT 2 (Ø1/4" x 38mm - RBW)		10PCS	9	BIG FLAT WASHER (Ø1/4" X 25 X 1.5mm - RBW)		22PCS
4	BOLT 3 (Ø1/4" x 60mm - RBW)		10PCS	10	SMALL FLAT WASHER (Ø1/4" X 19 X 1.5mm - RBW)		22PCS
5	BOLT 4 (Ø1/4" x 90mm - RBW)		8PCS	11	LOCK WASHER (Ø1/4" - RBW)		22PCS
6	SHORT PAN HEAD SCREW (#4 x 20mm - RBW)		4PCS	12	LEVELER (Ø1/4" X 25mm - BLK)		6PCS

NOTE:

Phillips head screw driver is required in the assembly process; however, manufacturer does not provide this item.

ASSEMBLY INSTRUCTIONS

STEP 1

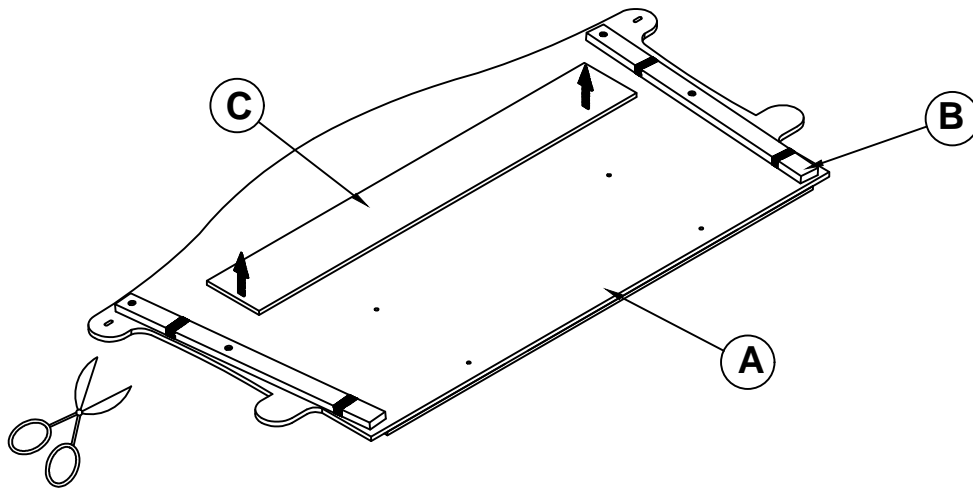

STEP 2

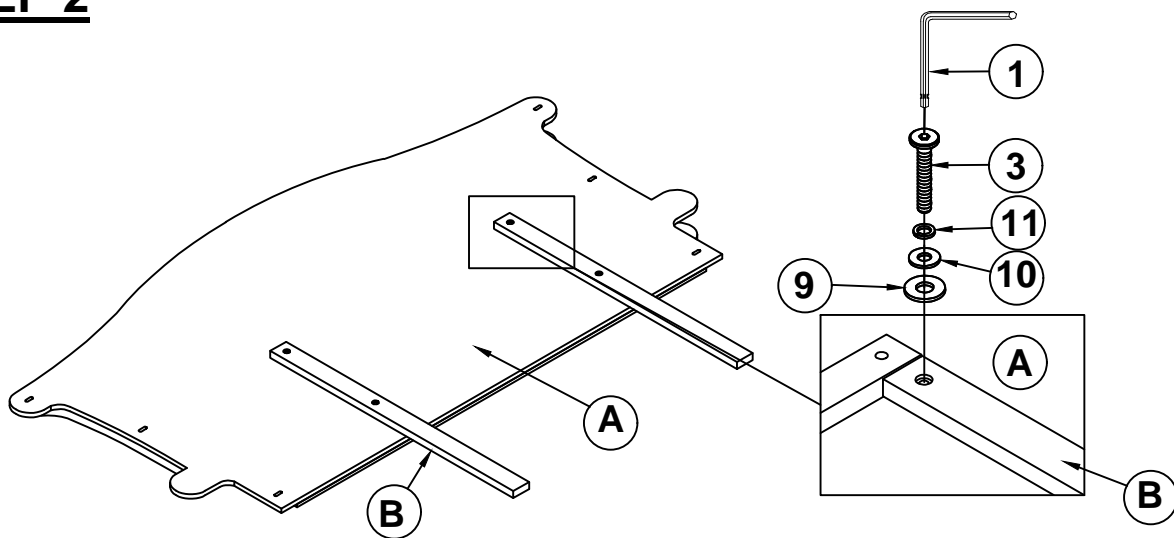

STEP 3

NOTE : THE EAR PANELSUPPORTS ARE TO LIFT UP THE BED RAILS

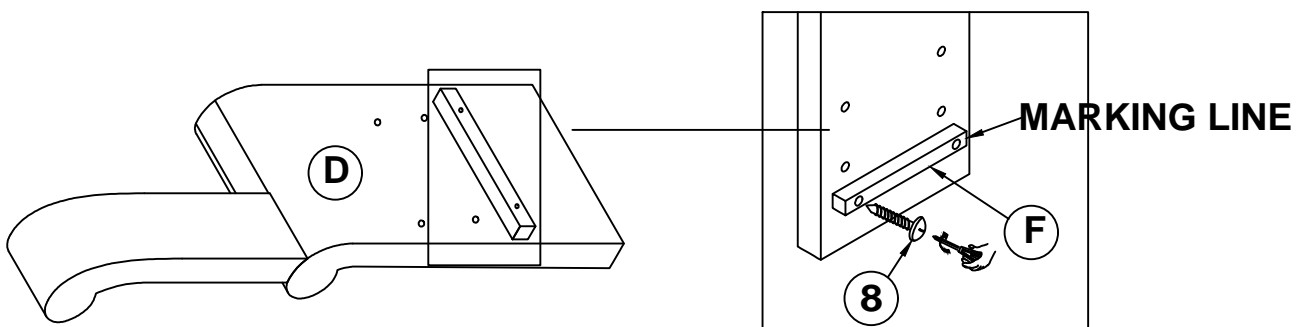

ASSEMBLY INSTRUCTIONS

STEP 4

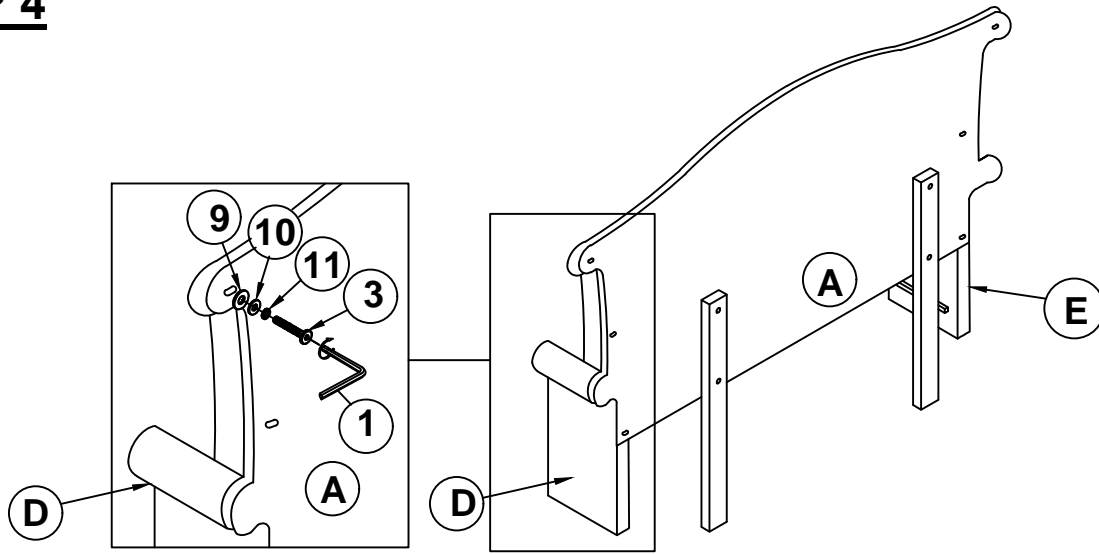

STEP 5

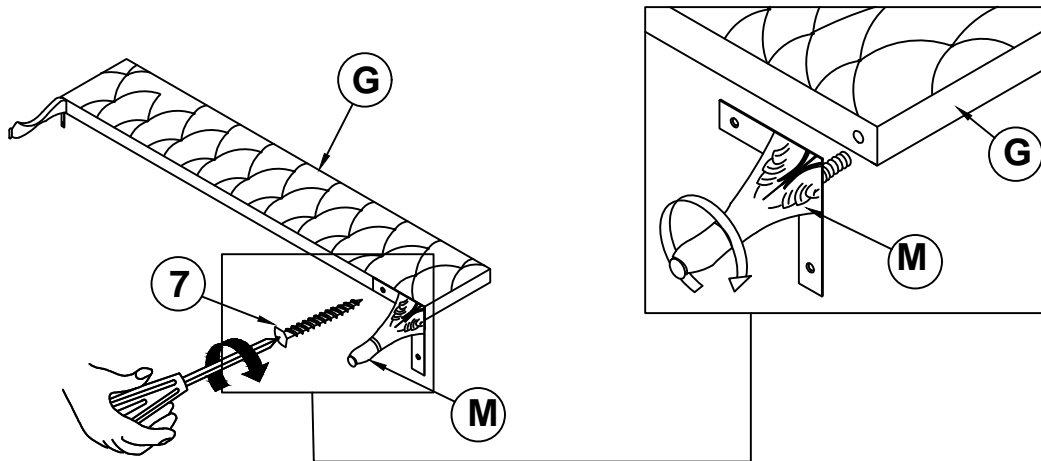

STEP 6

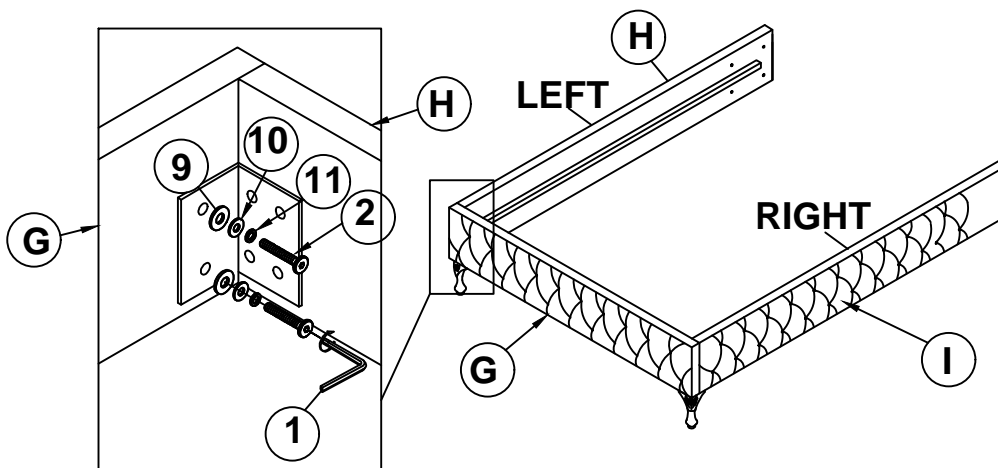

ASSEMBLY INSTRUCTIONS

STEP 7

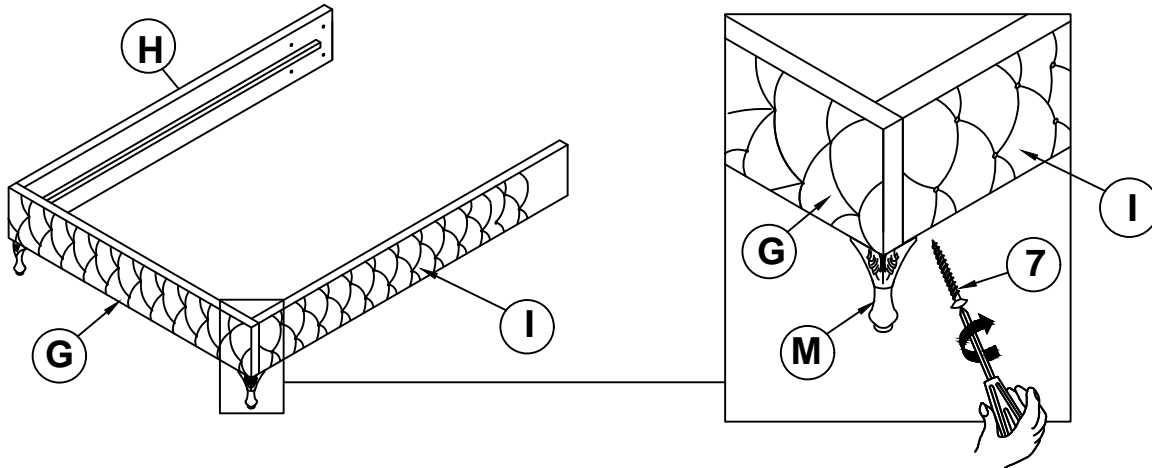

STEP 8

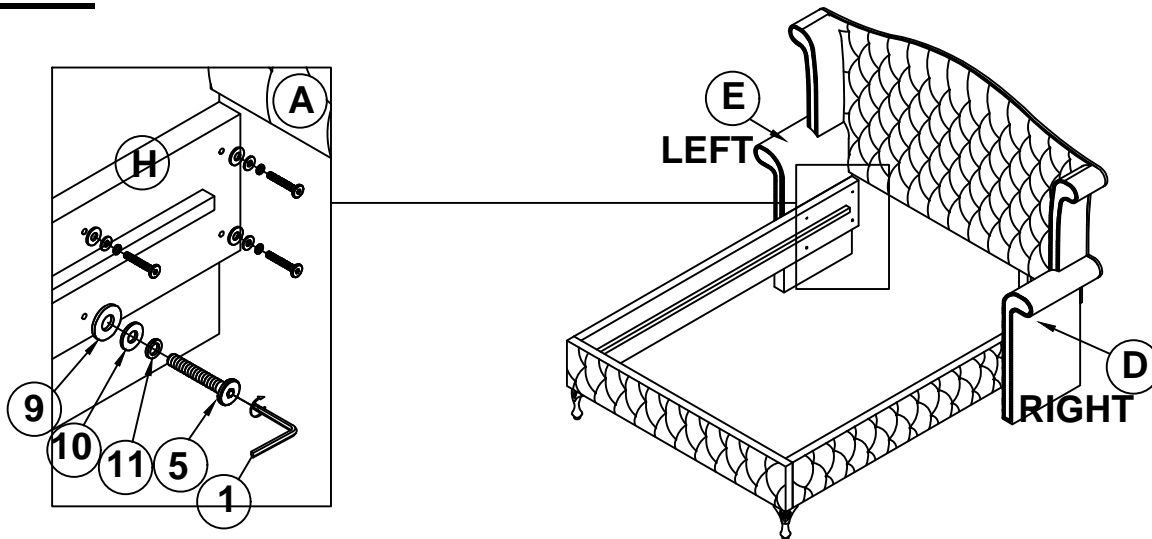

STEP 9

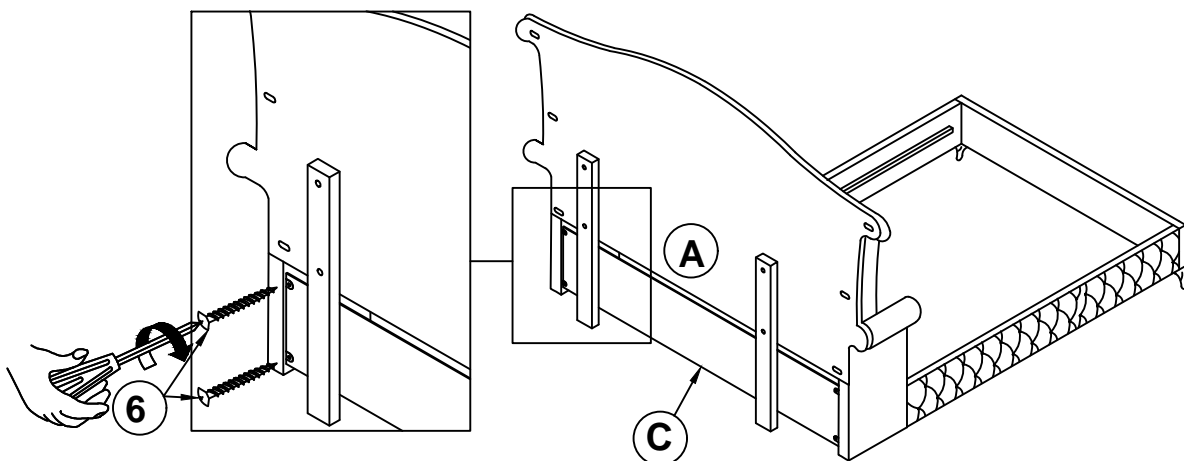

ASSEMBLY INSTRUCTIONS

STEP 10

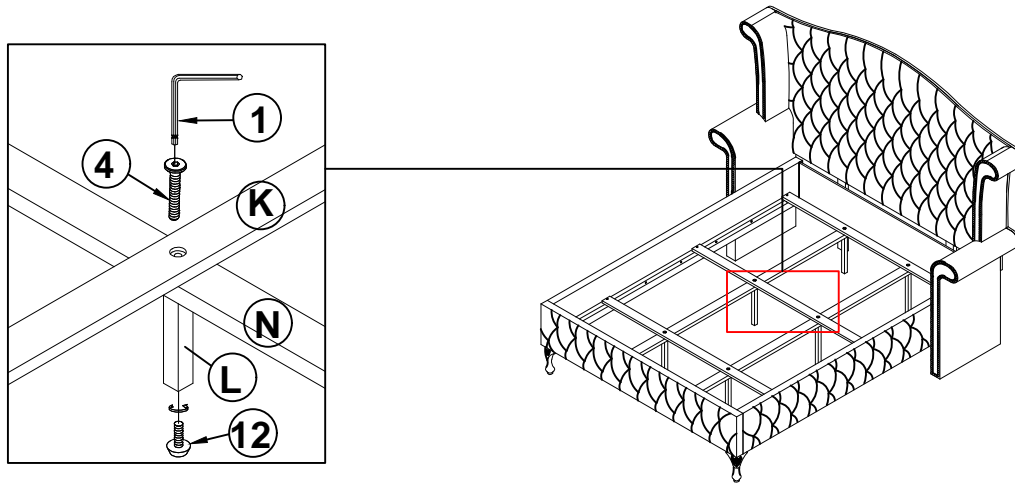

STEP 11

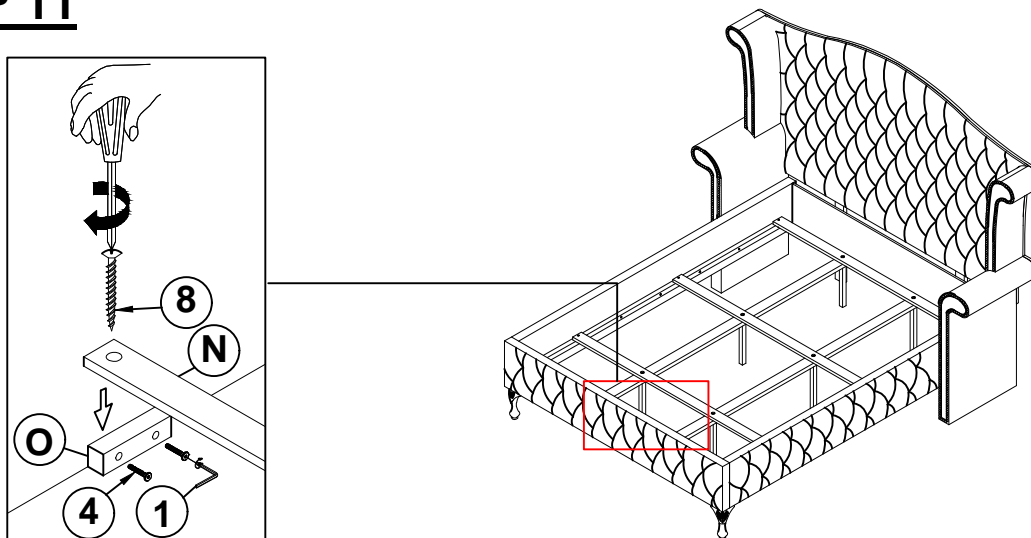

STEP 12

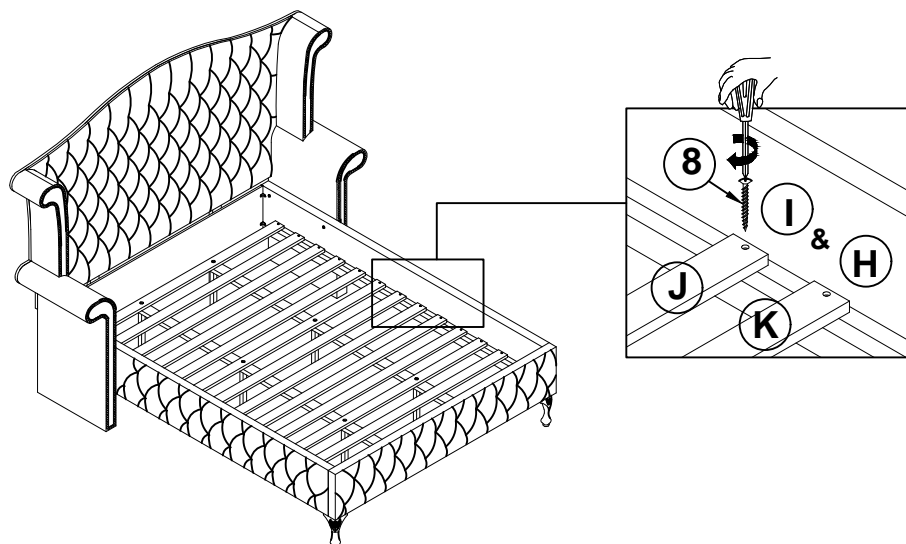

ITEM: **206101Q (B1-B3)**



ASSEMBLY INSTRUCTIONS

STEP 13

COMPLETE

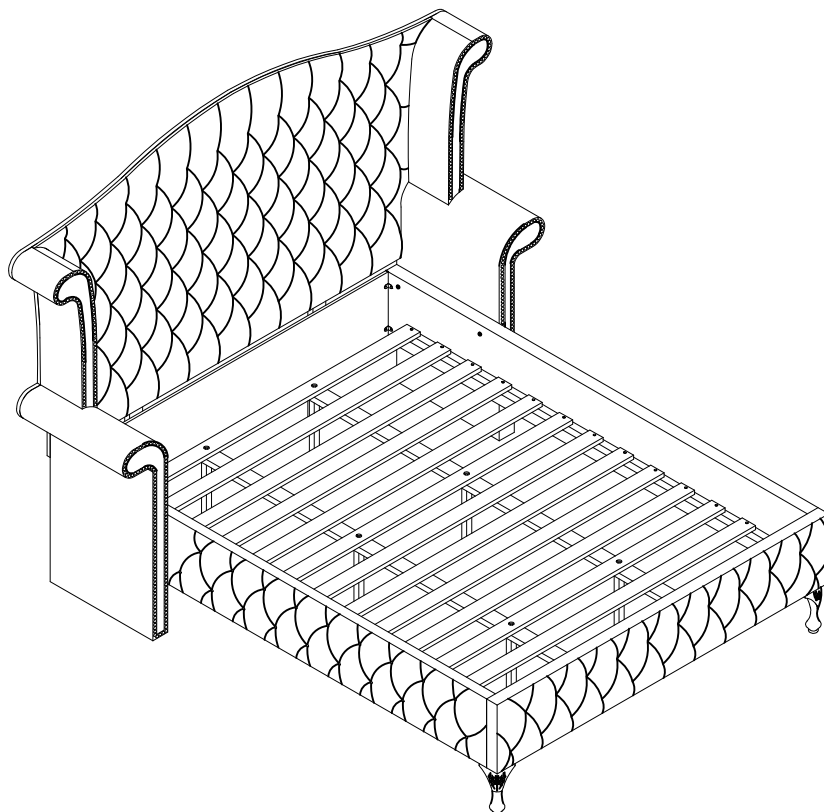

ITEM: **206101Q (B1-B3)**



Inner Size: 61.00"W X 81.00"D

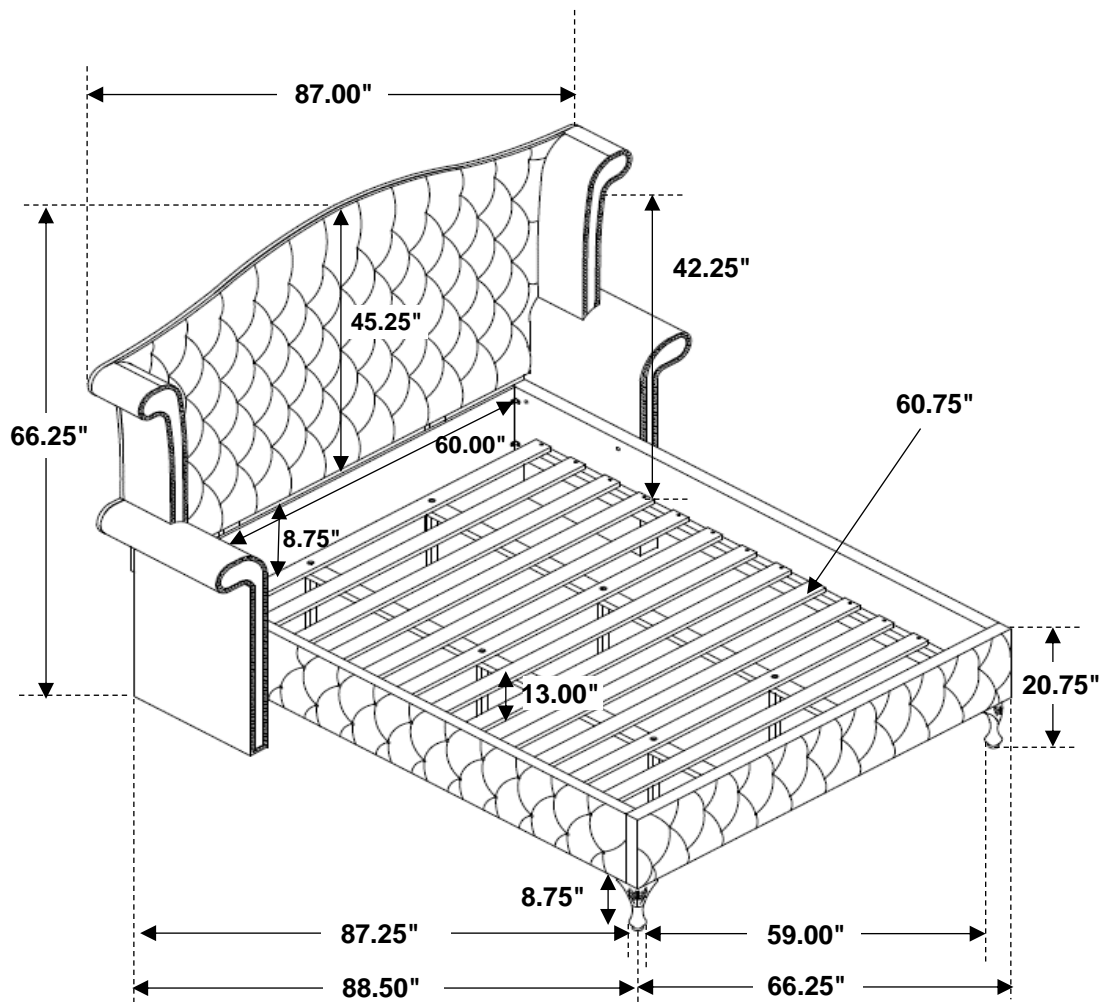

Note: Dimension tolerance $\pm 5\%$

ASSEMBLY INSTRUCTIONS
COASTER FINE FURNITURE



Fine Furniture for every stage of life

206101KE (B1-B3)
Eastern King Bed

ITEM: 206101KE (B1-B3)



ASSEMBLY INSTRUCTIONS

ASSEMBLY TIPS:

1. Remove hardware from box and sort by size.
2. Please check to see that all hardware and parts are present prior to start of assembly.
3. Please follow attached instructions in the same sequence as numbered to assure fast & easy assembly.



WARNING!

1. Don't attempt to repair or modify parts that are broken or defective. Please contact the store immediately.
2. This product is for home use only and not intended for commercial establishments.





ASSEMBLY TIME



40 MINUTES

PARTS IDENTIFICATION











B1 (BOX 1)

A	HEADBOARD		1PC	C	HEADBOARD PANEL		1PC
B	HEADBOARD SUPPORT LEG		2PCS				

B2 (BOX 2)

D	RIGHT EAR PANEL		1PC	F	EAR PANEL SUPPORT		2PCS
E	LEFT EAR PANEL		1PC				

B3 (BOX 3)

G	FOOTBOARD		1PC	M	FOOTBOARD LEG		2PCS
H	LEFT BED RAIL		1PC	N	CENTER RAIL		2PCS
I	RIGHT BED RAIL		1PC	O	CENTER RAIL SUPPORT		2PCS
J	BED SLAT		10PCS	HB	206101KE (B1) FROM BOX 1 HEADBOARD COMPLETE		1PC
K	BED SLAT WITH HOLES		3PCS	ER	206101KE (B2) FROM BOX 2 LEFT AND RIGHT EAR PANEL COMPLETE		2PCS
L	BED SLAT SUPPORT		6PCS				

NOTE:

Phillips head screw driver is required in the assembly process; however, manufacturer does not provide this item.

ITEM: 206101KE (B1-B3)



ASSEMBLY INSTRUCTIONS

ASSEMBLY TIPS:

1. Remove hardware from box and sort by size.
2. Please check to see that all hardware and parts are present prior to start of assembly.
3. Please follow attached instructions in the same sequence as numbered to assure fast & easy assembly.















WARNING!

1. Don't attempt to repair or modify parts that are broken or defective. Please contact the store immediately.
2. This product is for home use only and not intended for commercial establishments.

HARDWARE IDENTIFICATION

Z-B3 (BOX 3) - HARDWARE PACK IS LOCATED IN 206101KE (B3)

1	ALLEN WRENCH (4MM - RBW)		1PC	7	MEDIUM PAN HEAD SCREW (#4 x 25mm - RBW)		4PCS
2	BOLT 1 (Ø1/4" x 30mm - RBW)		4PCS	8	LONG PAN HEAD SCREW (#4 x 38mm - RBW)		32PCS
3	BOLT 2 (Ø1/4" x 38mm - RBW)		10PCS	9	BIG FLAT WASHER (Ø1/4" X 25 X 1.5mm - RBW)		22PCS
4	BOLT 3 (Ø1/4" x 60mm - RBW)		10PCS	10	SMALL FLAT WASHER (Ø1/4" X 19 X 1.5mm - RBW)		22PCS
5	BOLT 4 (Ø1/4" x 90mm - RBW)		8PCS	11	LOCK WASHER (Ø1/4" - RBW)		22PCS
6	SHORT PAN HEAD SCREW (#4 x 20mm - RBW)		4PCS	12	LEVELER (Ø1/4" X 25mm - BLK)		6PCS

NOTE:

Phillips head screw driver is required in the assembly process; however, manufacturer does not provide this item.

ASSEMBLY INSTRUCTIONS

STEP 1

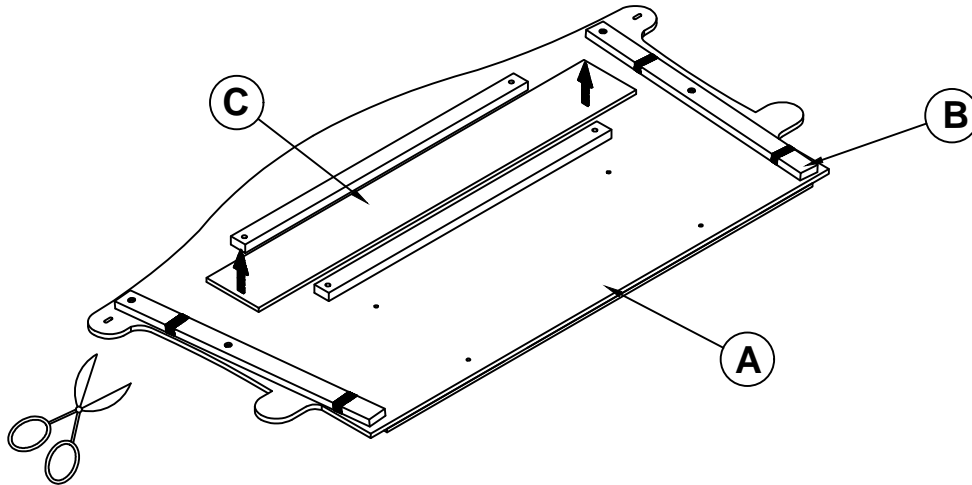

STEP 2

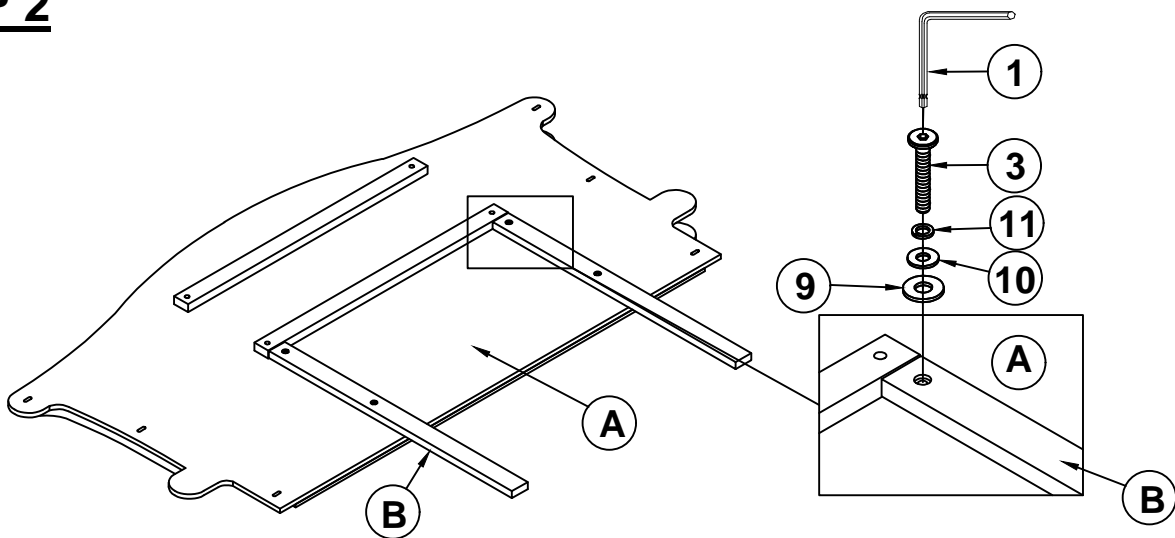

STEP 3

NOTE : THE EAR PANELSUPPORTS ARE TO LIFT UP THE BED RAILS

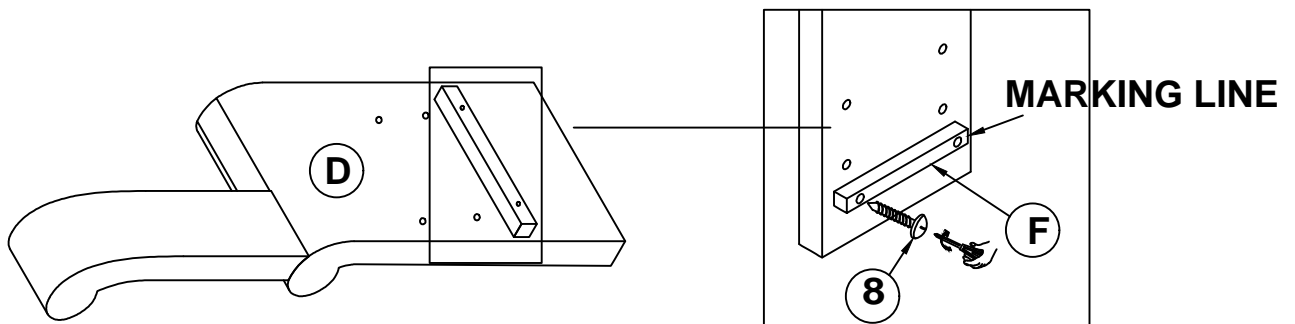

ASSEMBLY INSTRUCTIONS
STEP 4

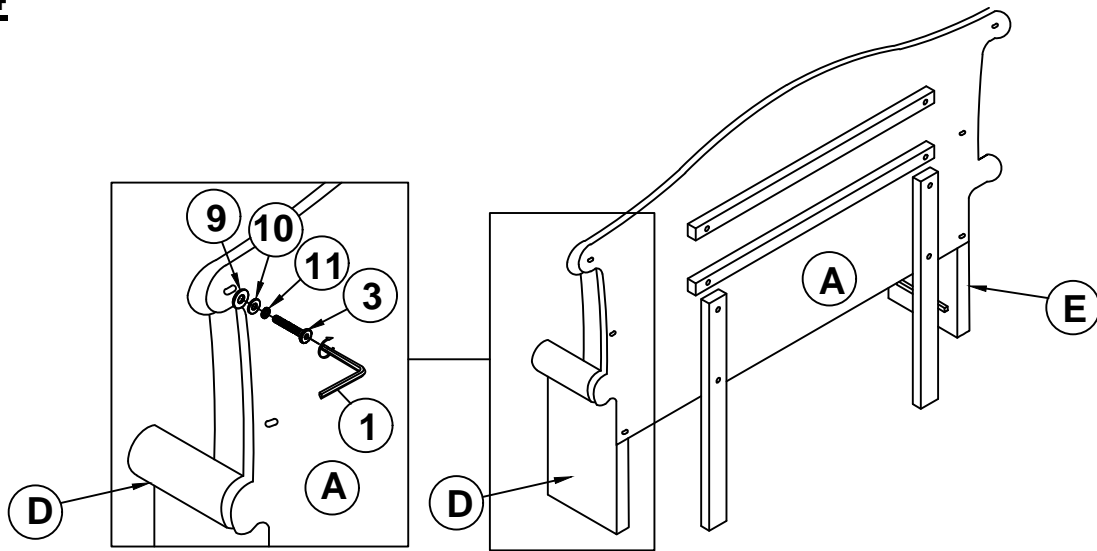

STEP 5

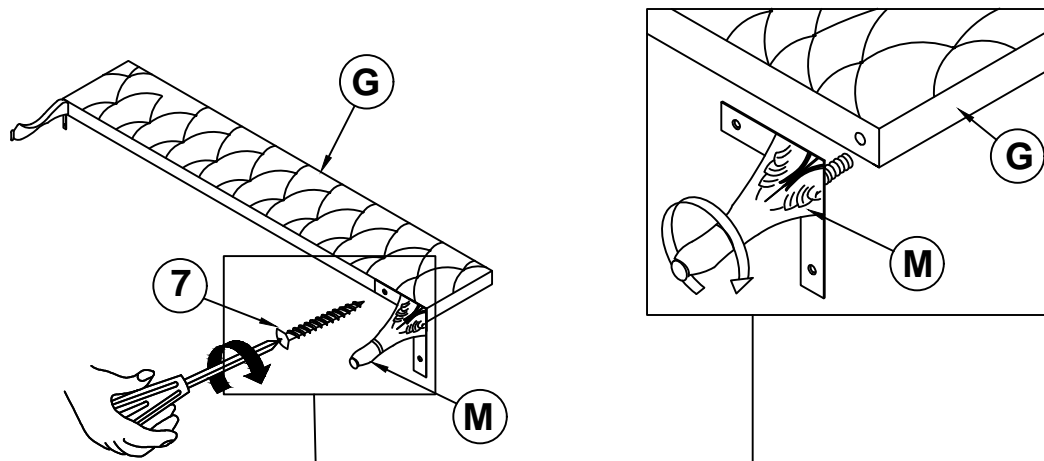

STEP 6

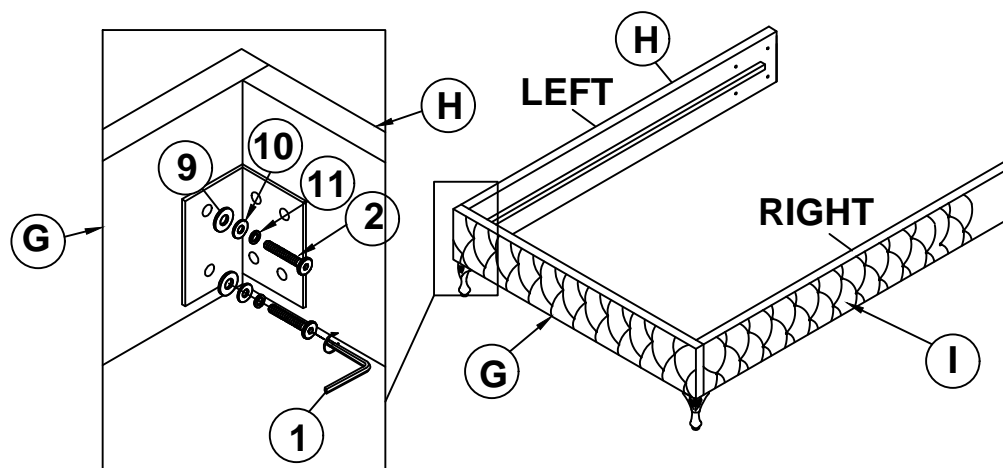

ASSEMBLY INSTRUCTIONS
STEP 7

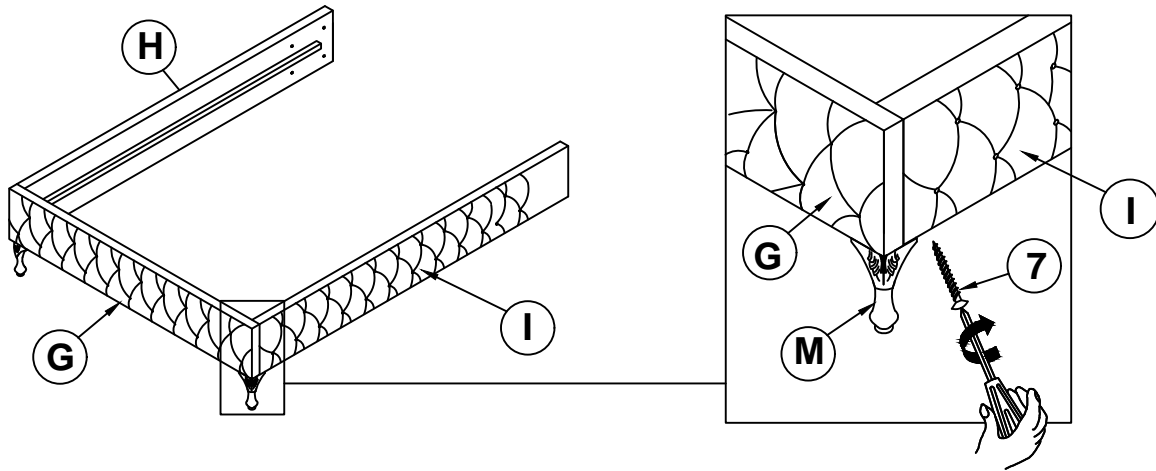

STEP 8

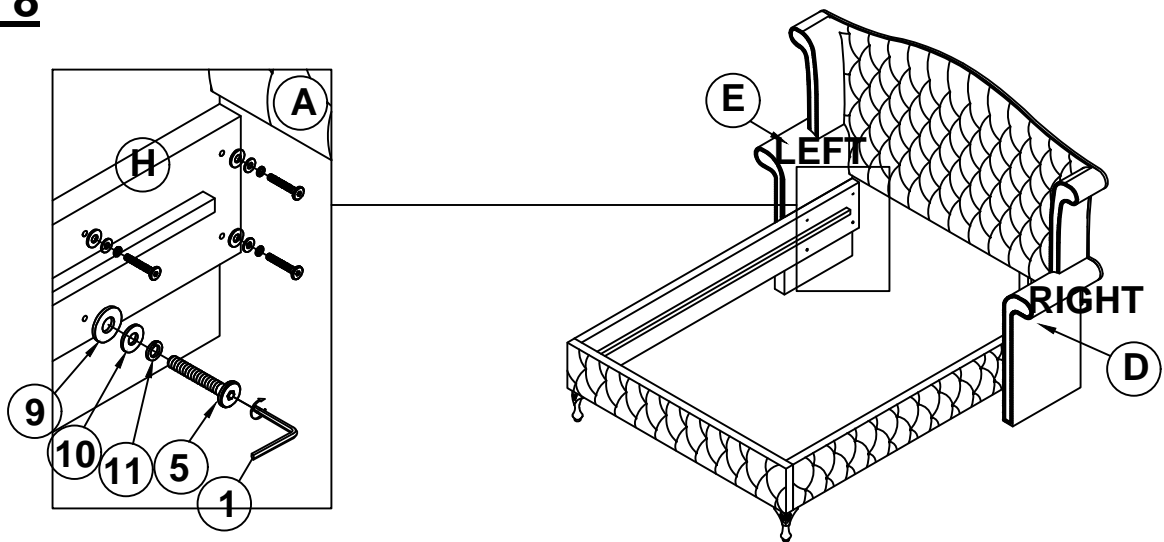

STEP 9

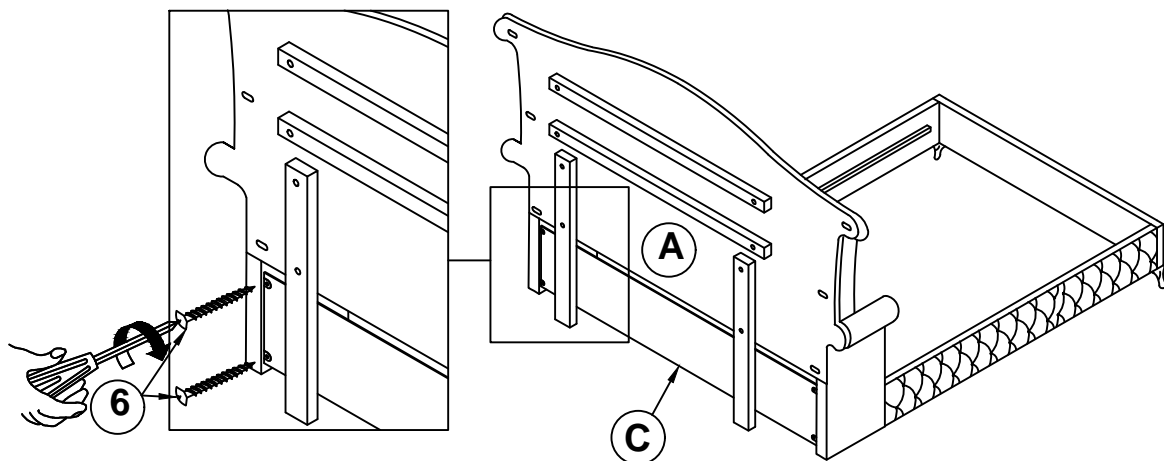

ASSEMBLY INSTRUCTIONS

STEP 10

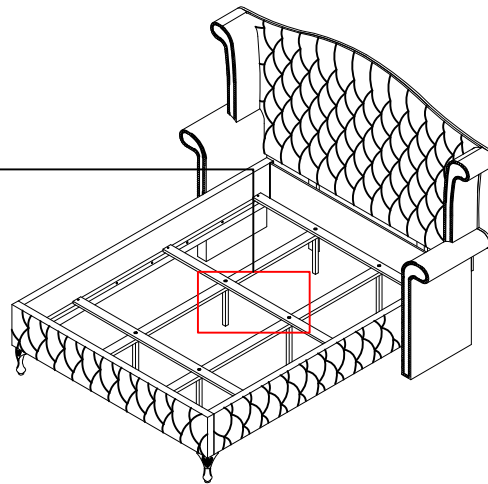
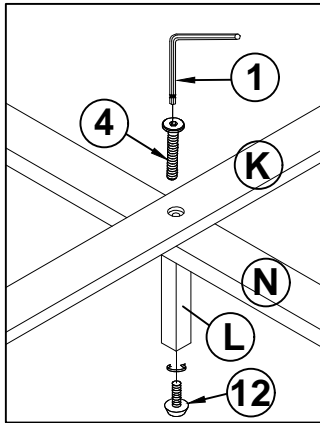

STEP 11

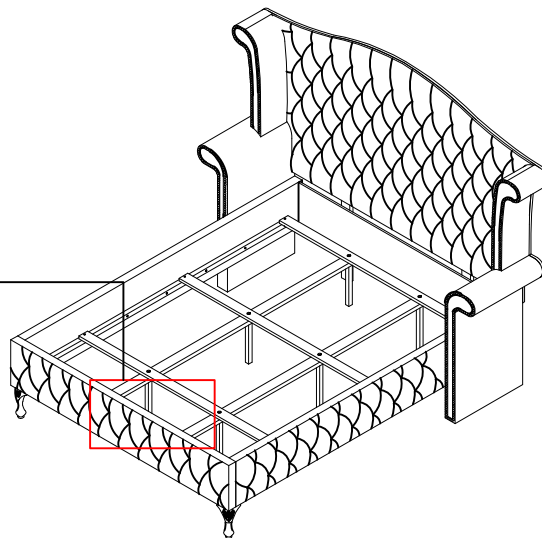
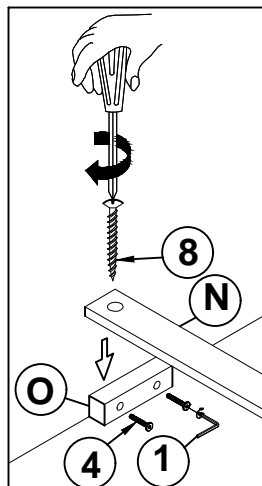

STEP 12

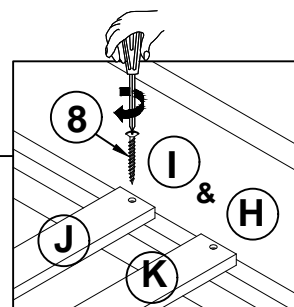
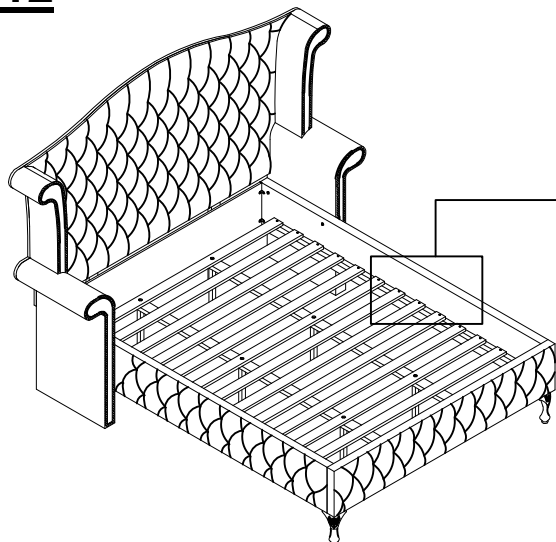

ITEM: **206101KE (B1-B3)**



ASSEMBLY INSTRUCTIONS

STEP 13

COMPLETE

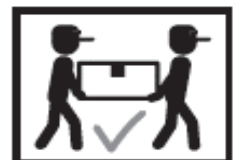
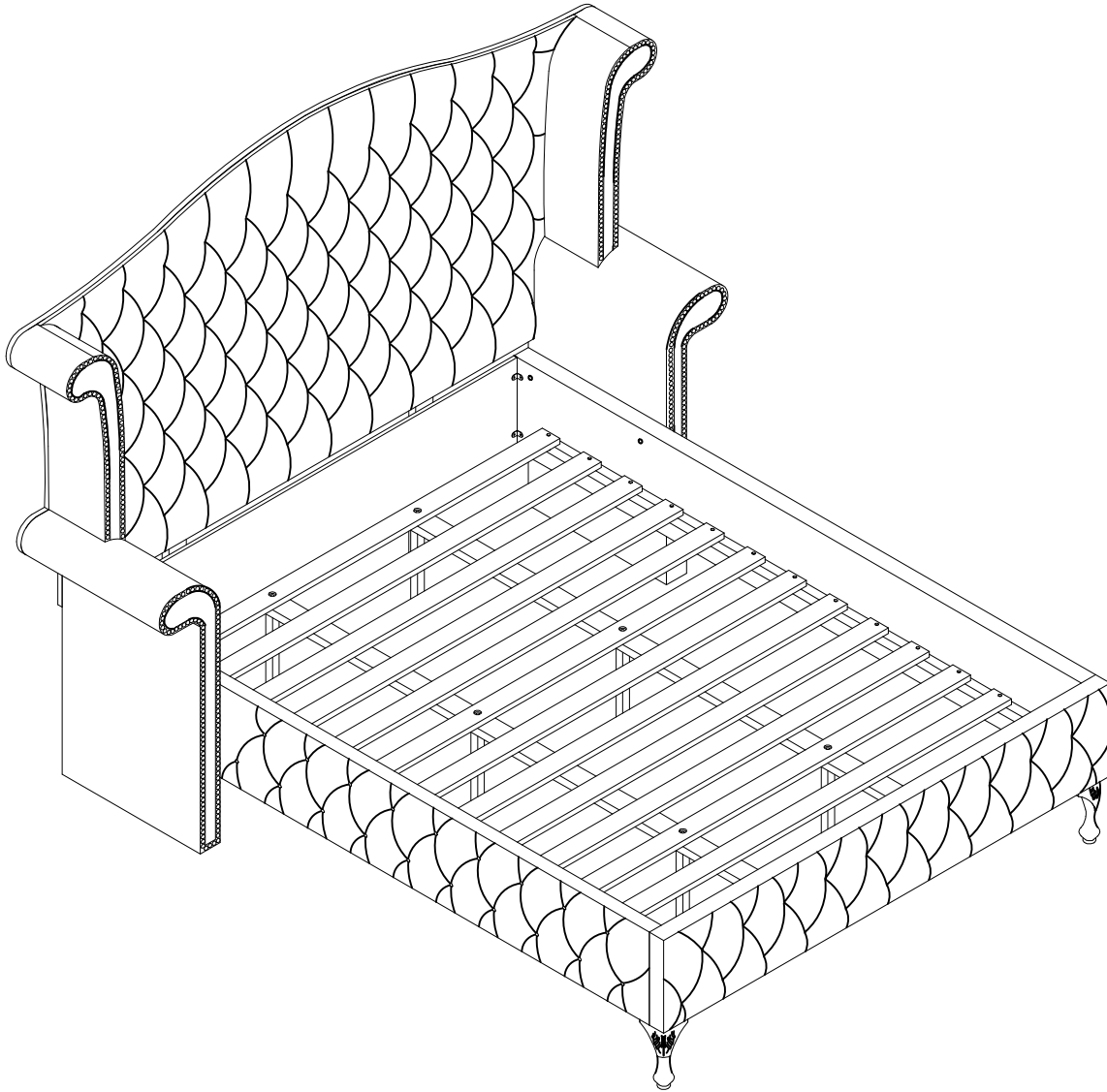

ITEM: 206101KE (B1-B3)



Inner Size: 77.00"W X 81.00"D

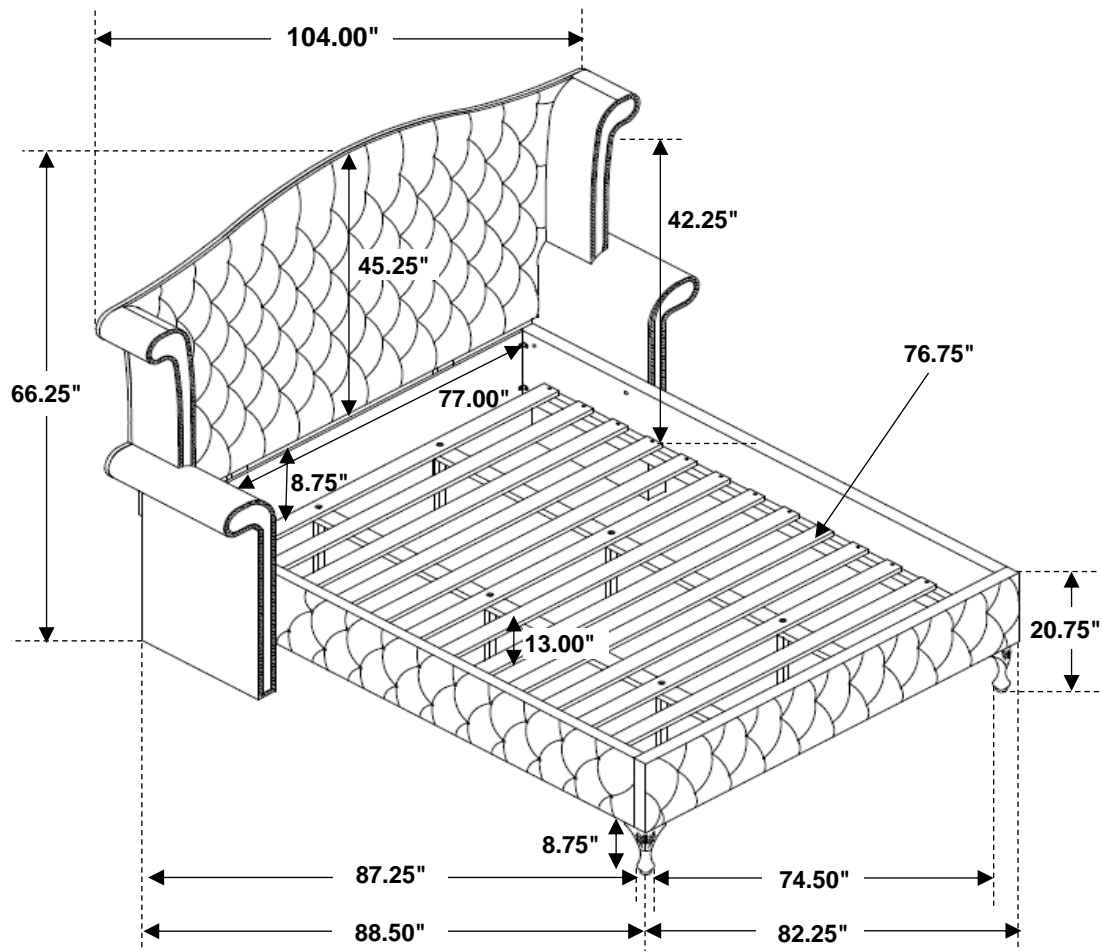

Note: Dimension tolerance $\pm 5\%$

ASSEMBLY INSTRUCTIONS
COASTER FINE FURNITURE



Fine Furniture for every stage of life

206102
Nightstand

ITEM: 206102



ASSEMBLY INSTRUCTIONS

ASSEMBLY TIPS:

1. Remove hardware from box and sort by size.
2. Please check to see that all hardware and parts are present prior to start of assembly.
3. Please follow attached instructions in the same sequence as numbered to assure fast & easy assembly.



WARNING!

1. Don't attempt to repair or modify parts that are broken or defective. Please contact the store immediately.
2. This product is for home use only and not intended for commercial establishments.



ASSEMBLY TIME

10 MINUTES

PARTS IDENTIFICATION

A NIGHTSTAND

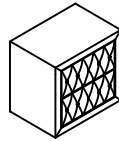

1PC

B

LEG



4PCS

HARDWARE IDENTIFICATION

1 ALLEN WRENCH
(4MM - RBW)



1PC

3 LOCK WASHER
(Ø5/16" - RBW)



4PCS

2 BOLT
(Ø5/16" x 90mm - RBW)



4PCS

4 FLAT WASHER
(Ø5/16" x 19 x 1.5mm - RBW)



4PCS

NOTE:

Phillips head screw driver is required in the assembly process; however, manufacturer does not provide this item.

ITEM: **206102**

ASSEMBLY INSTRUCTIONS

STEP 1

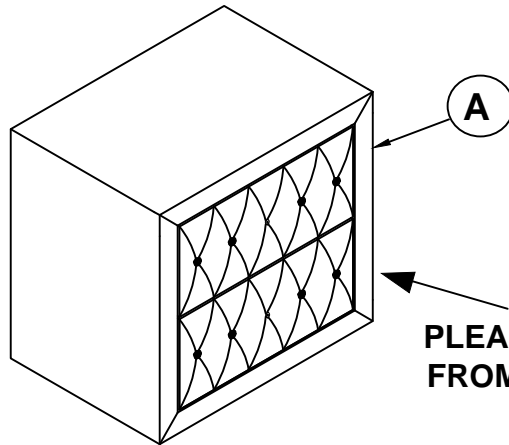

PLEASE TAKE OUT THE LEGS
FROM THE LAST DRAWER.

STEP 2

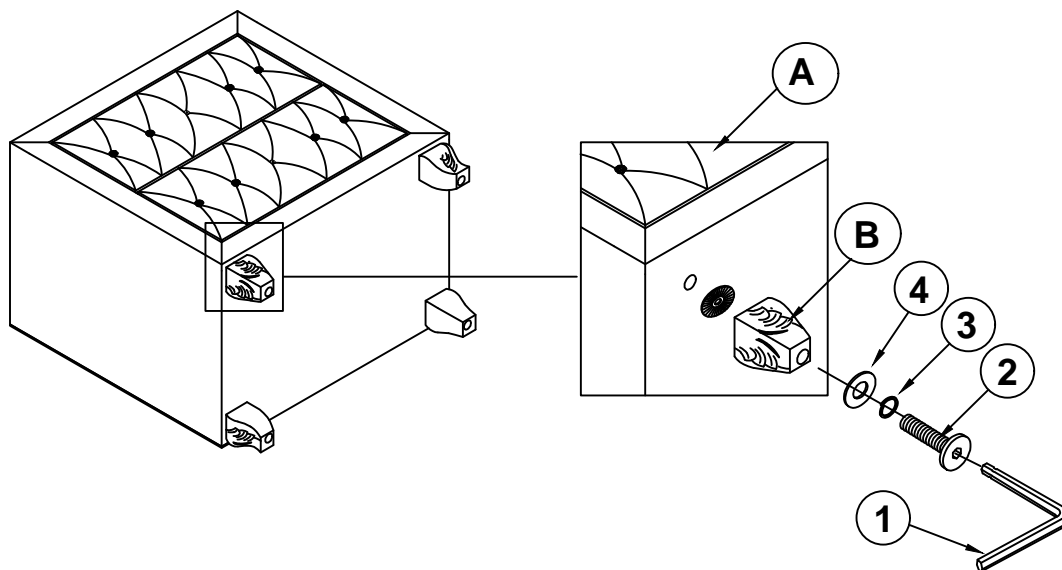

ITEM: **206102**



ASSEMBLY INSTRUCTIONS

STEP 3

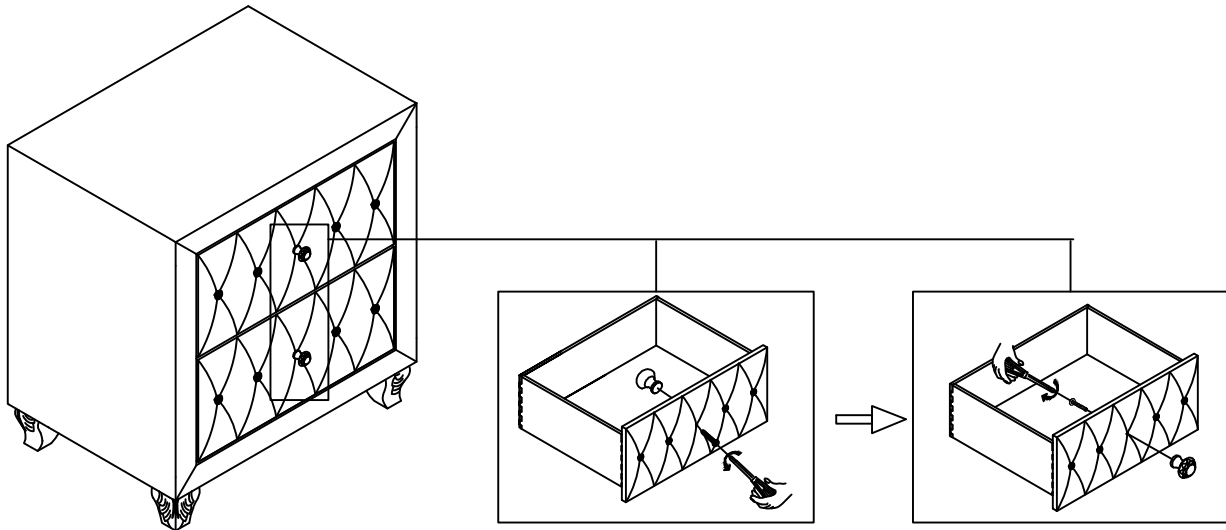

STEP 4

COMPLETE

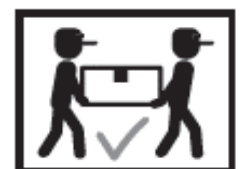
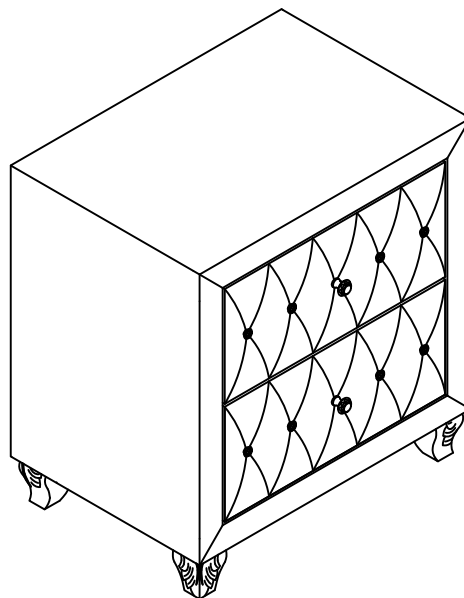

ITEM: **206102**



ANTI-TIPPING INSTALLMENT INSTRUCTIONS

FURNITURE TIPPING RESTRAINT

WARNING

Injury may result from tipping furniture.
This restraint may protect against tipping furniture.
Do not allow children to climb on furniture.
This restraint is not a substitute for proper adult supervision.
Failure to detach this restraint before moving the furniture may result in injury and damage.

1. Attach one of the mounting brackets securely to the back edge of the furniture. Use the short screw.
2. Determine where the furniture is to be placed and mark location on the wall for the mounting bracket screw hole approximately 2" below the bracket mounted to the edge of the furniture.
3. Drill a 3/16" hole in the wall. Press the plastic wall plug into the hole and gently tap until the flange on the wall plug is against the wall surface.
4. Position the bracket over the wall plug and use the long screw to securely attach the bracket to the wall.
5. Place the furniture so the bracket on the back edge is in line with the bracket on the wall.
6. Lace an end of the cable tie down through each bracket. Bring both ends together and slide the beaded end of the cable tie through the keyhole shaped slot on the other end until snug. Pull down on the beaded end until it snap locks into the keyhole slot.
7. To double lock return the beaded end back through the keyhole as shown.
8. Check to make sure the cable tie is securely laced and locked to the brackets.

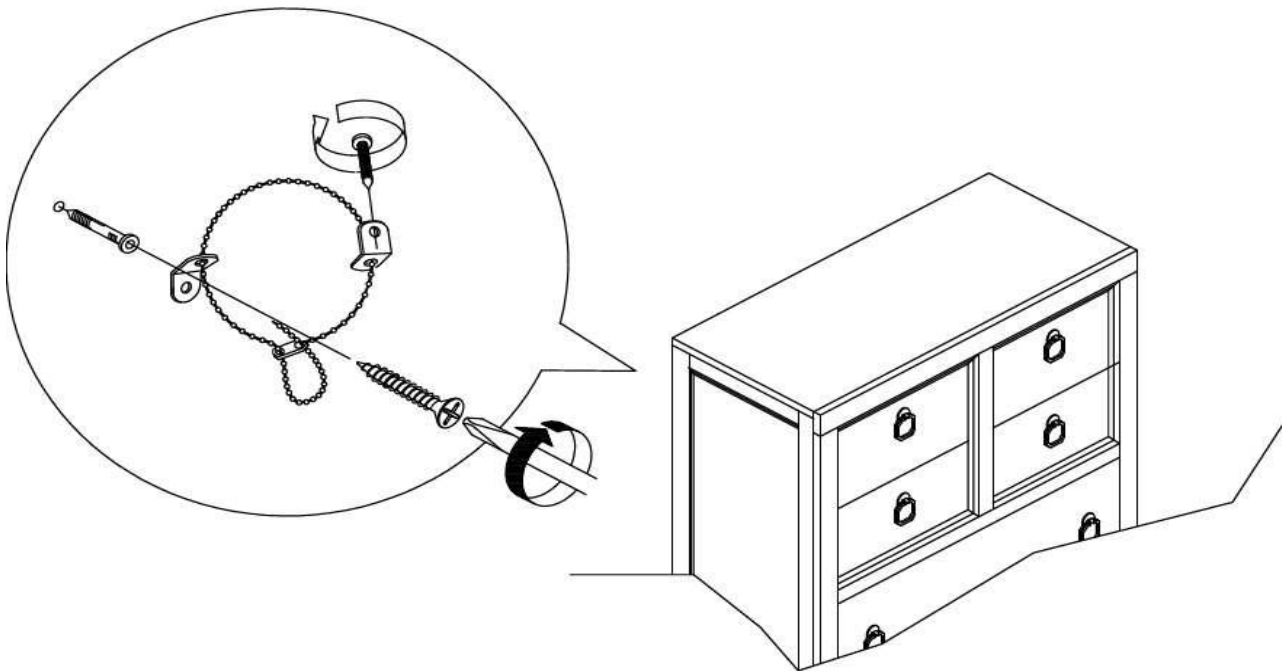

ITEM: **206102**



Inner Size of Drawer : 19.00"W X 14.50"D X 6.00"H X 0.25"T

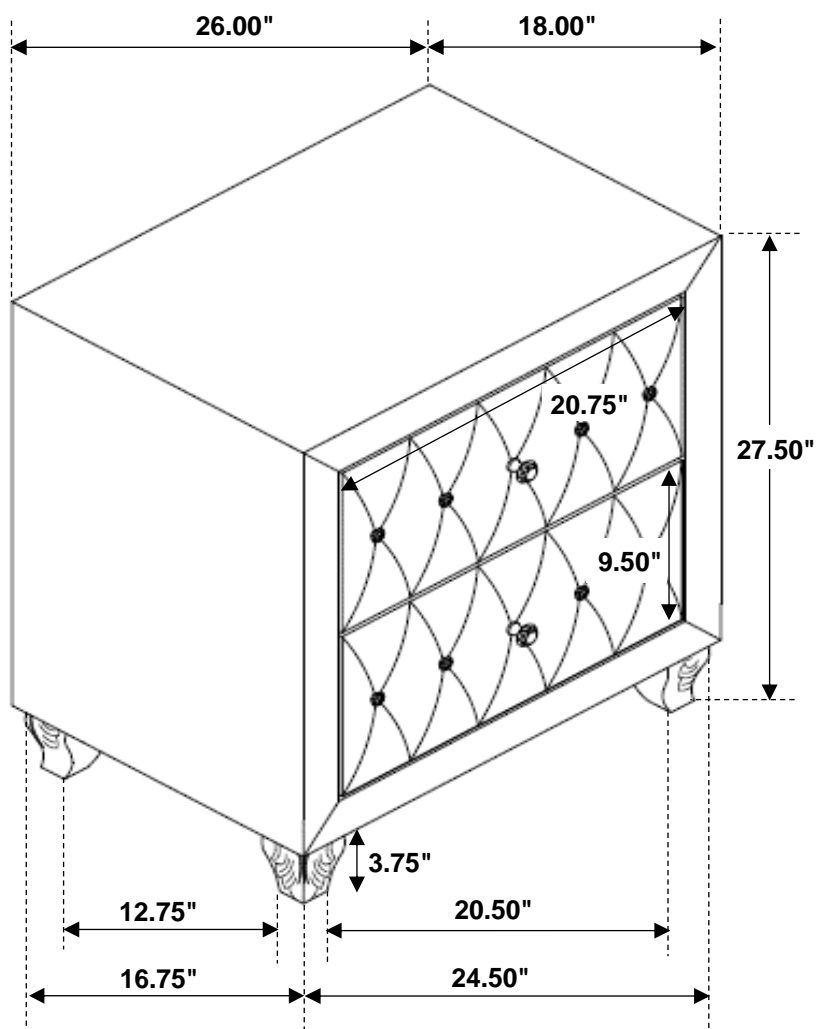

Note: Dimension tolerance $\pm 5\%$

ASSEMBLY INSTRUCTIONS
COASTER FINE FURNITURE



Fine Furniture for every stage of life

206103
Dresser

ITEM: 206103



ASSEMBLY INSTRUCTIONS

ASSEMBLY TIPS:

1. Remove hardware from box and sort by size.
2. Please check to see that all hardware and parts are present prior to start of assembly.
3. Please follow attached instructions in the same sequence as numbered to assure fast & easy assembly.



WARNING!



1. Don't attempt to repair or modify parts that are broken or defective. Please contact the store immediately.
2. This product is for home use only and not intended for commercial establishments.





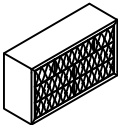

ASSEMBLY TIME

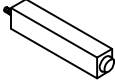
10 MINUTES

PARTS IDENTIFICATION

A	DRESSER		1PC	B	LEG		4PCS
C	CENTER SUPPORT LEG WITH LEVELER		1PC				

HARDWARE IDENTIFICATION

1	ALLEN WRENCH (4MM - RBW)		1PC	3	LOCK WASHER (Ø5/16" - RBW)		4PCS
2	BOLT (Ø5/16" x 90mm - RBW)		4PCS	4	FLAT WASHER (Ø5/16" x 19 x 1.5mm - RBW)		4PCS

NOTE:

Phillips head screw driver is required in the assembly process; however, manufacturer does not provide this item.

ITEM: **206103**

ASSEMBLY INSTRUCTIONS

STEP 1

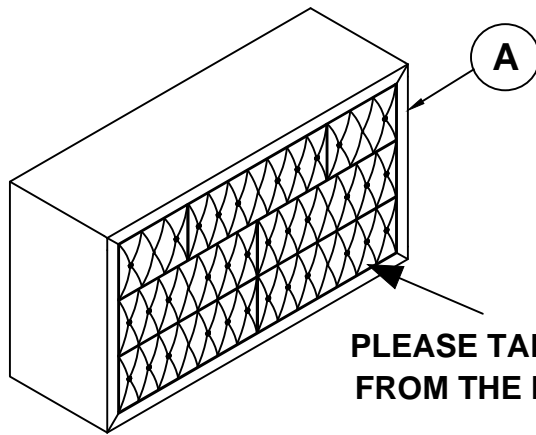

PLEASE TAKE OUT THE LEGS
FROM THE LAST DRAWER.

STEP 2

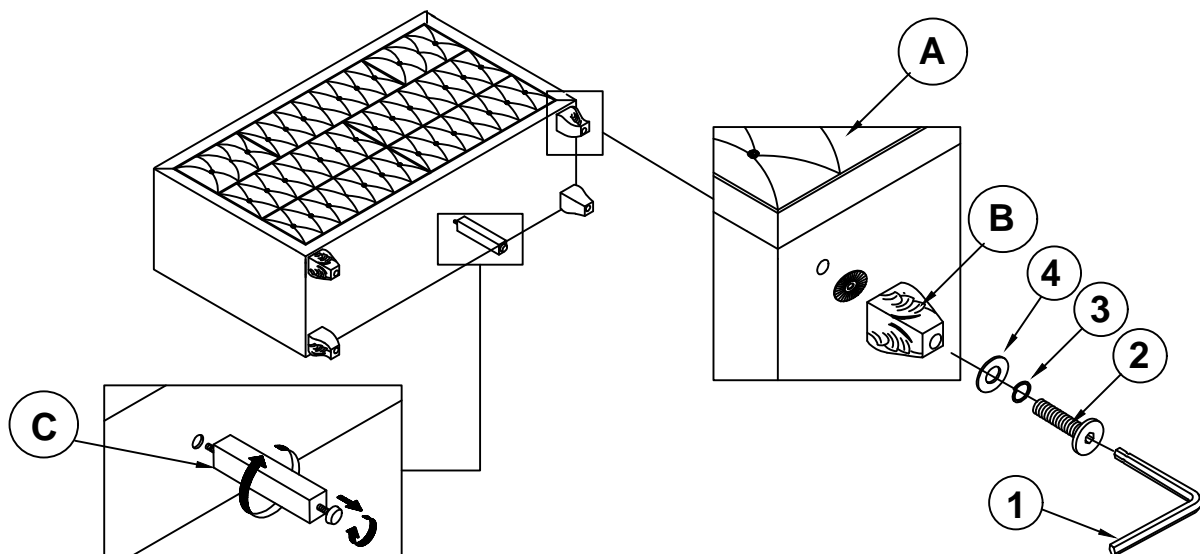

ITEM: **206103**



ASSEMBLY INSTRUCTIONS

STEP 3

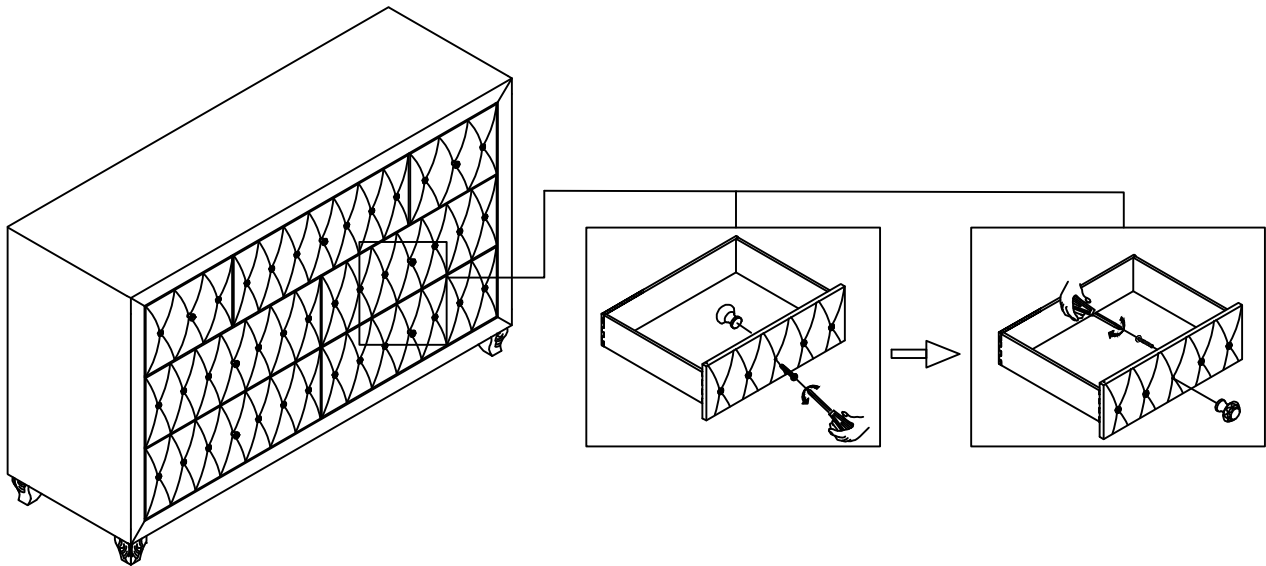

STEP 4 COMPLETE

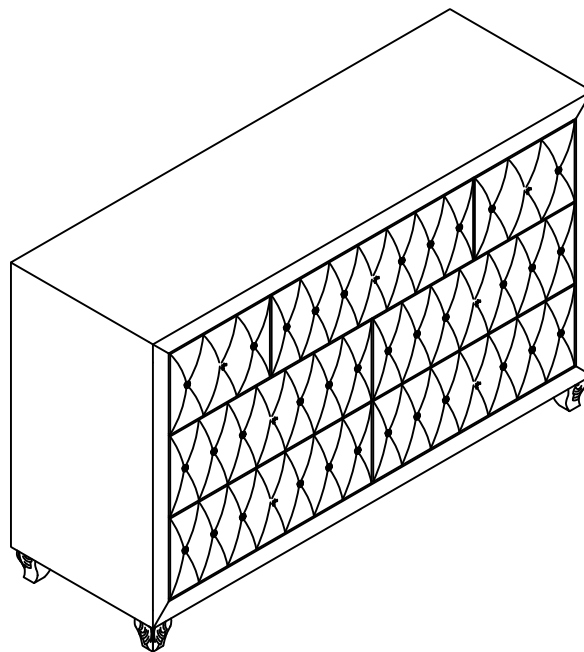

ITEM: **206103**



ANTI-TIPPING INSTALLMENT INSTRUCTIONS

FURNITURE TIPPING RESTRAINT

WARNING

Injury may result from tipping furniture.
This restraint may protect against tipping furniture.
Do not allow children to climb on furniture.
This restraint is not a substitute for proper adult supervision.
Failure to detach this restraint before moving the furniture may result in injury and damage.

1. Attach one of the mounting brackets securely to the back edge of the furniture. Use the short screw.
2. Determine where the furniture is to be placed and mark location on the wall for the mounting bracket screw hole approximately 2" below the bracket mounted to the edge of the furniture.
3. Drill a 3/16" hole in the wall. Press the plastic wall plug into the hole and gently tap until the flange on the wall plug is against the wall surface.
4. Position the bracket over the wall plug and use the long screw to securely attach the bracket to the wall.
5. Place the furniture so the bracket on the back edge is in line with the bracket on the wall.
6. Lace an end of the cable tie down through each bracket. Bring both ends together and slide the beaded end of the cable tie through the keyhole shaped slot on the other end until snug. Pull down on the beaded end until it snap locks into the keyhole slot.
7. To double lock return the beaded end back through the keyhole as shown.
8. Check to make sure the cable tie is securely laced and locked to the brackets.

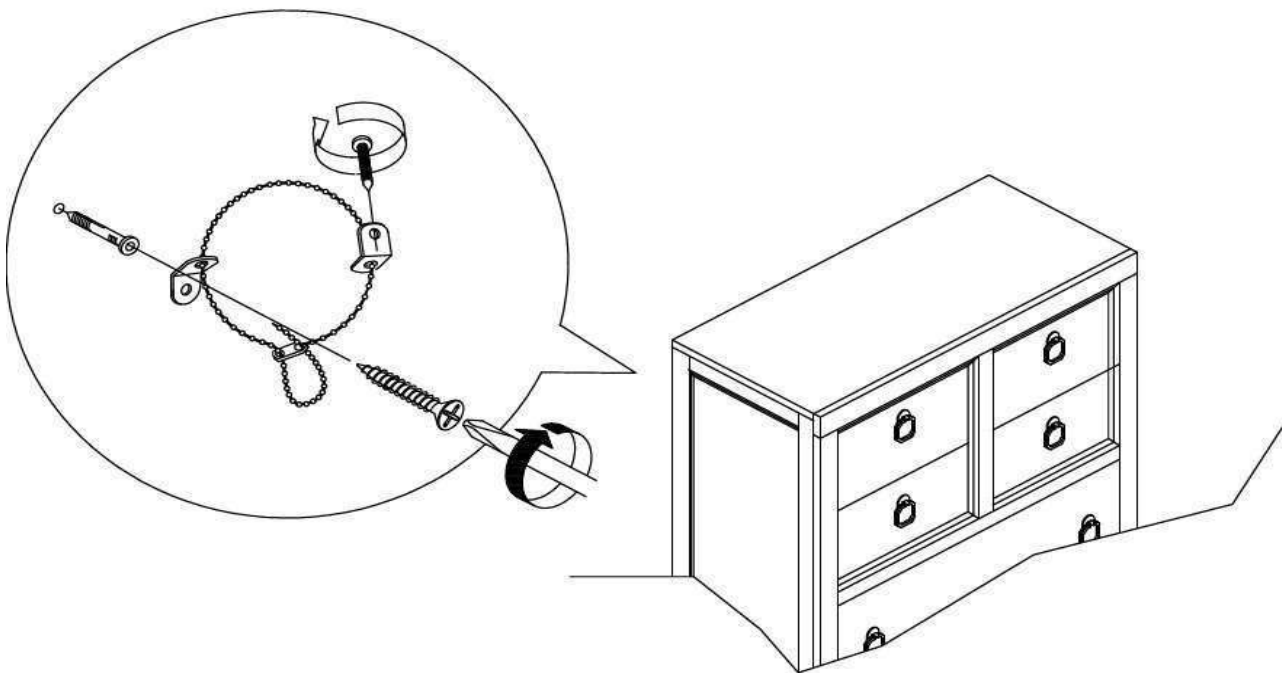

ITEM: **206103**



Inner Size of Drawer A : 11.50"W X 14.50"D X 6.00"H X 0.25"T
Inner Size of Drawer B : 25.25"W X 14.50"D X 6.00"H X 0.25"T
Inner Size of Drawer C : 25.75"W X 14.50"D X 6.00"H X 0.25"T

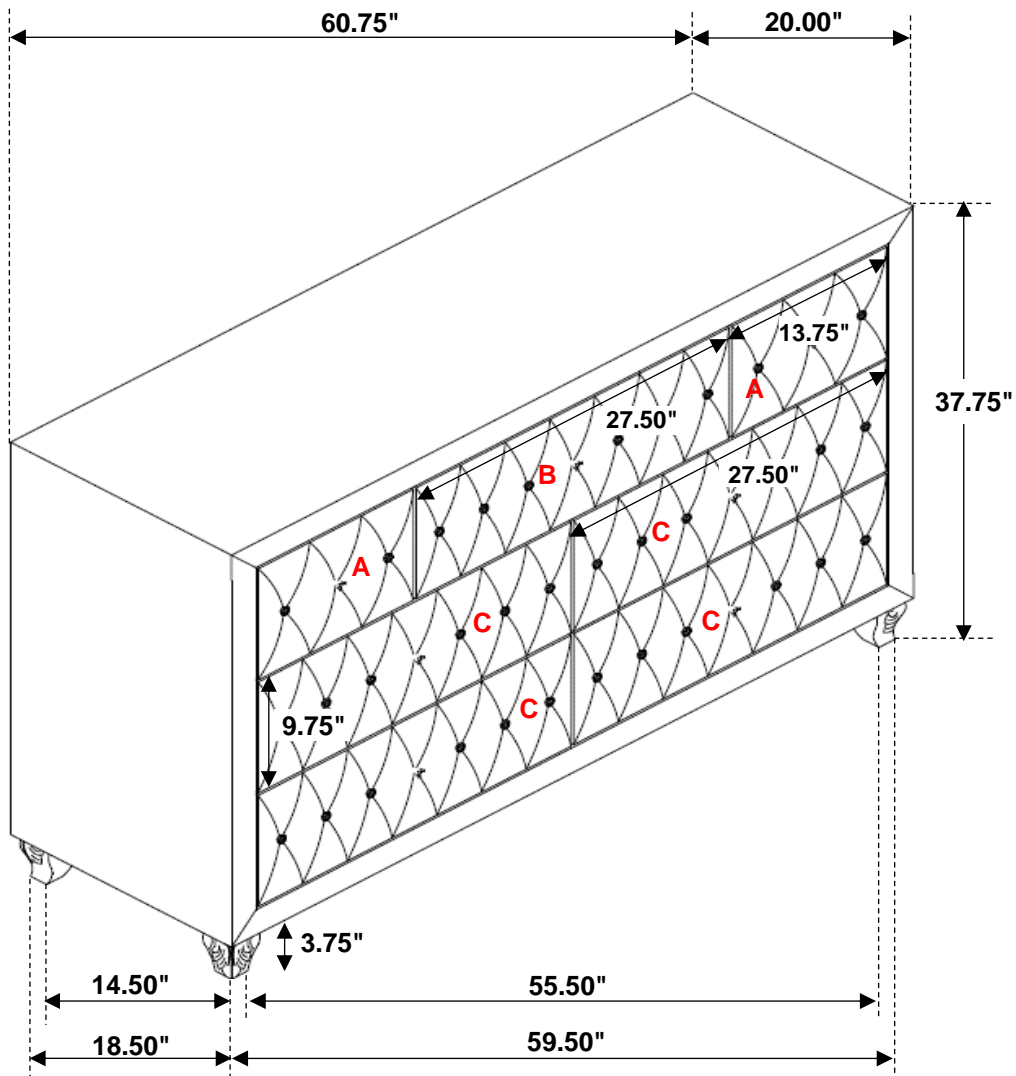

Note: Dimension tolerance $\pm 5\%$

ITEM:206104

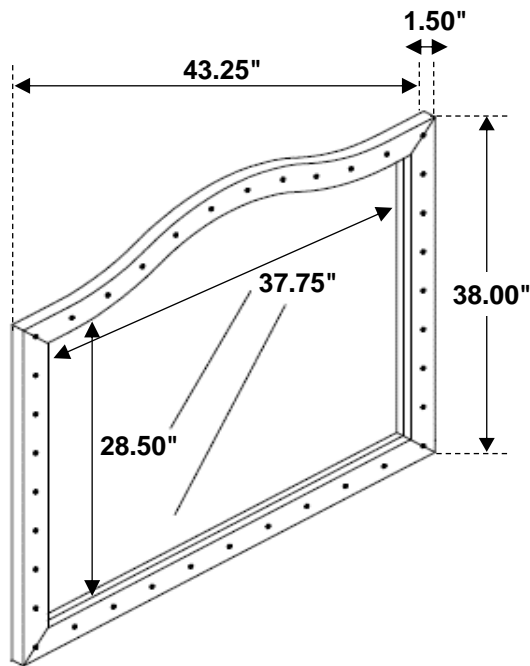

Note: Dimension tolerance $\pm 5\%$

ASSEMBLY INSTRUCTIONS
COASTER FINE FURNITURE



Fine Furniture for every stage of life

206105
Chest

ITEM: **206105**



ASSEMBLY INSTRUCTIONS

ASSEMBLY TIPS:

1. Remove hardware from box and sort by size.
2. Please check to see that all hardware and parts are present prior to start of assembly.
3. Please follow attached instructions in the same sequence as numbered to assure fast & easy assembly.



WARNING!

1. Don't attempt to repair or modify parts that are broken or defective. Please contact the store immediately.
2. This product is for home use only and not intended for commercial establishments.



ASSEMBLY TIME

10 MINUTES

PARTS IDENTIFICATION

A CHEST

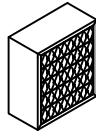

1PC

B

LEG



4PCS

HARDWARE IDENTIFICATION

1 ALLEN WRENCH
(4MM - RBW)



1PC

3

LOCK WASHER
(Ø5/16" - RBW)



4PCS

2 BOLT
(Ø5/16" x 90mm - RBW)



4PCS

4

FLAT WASHER
(Ø5/16" x 19 x 1.5mm - RBW)



4PCS

NOTE:

Phillips head screw driver is required in the assembly process; however, manufacturer does not provide this item.

ITEM: **206105**

ASSEMBLY INSTRUCTIONS

STEP 1

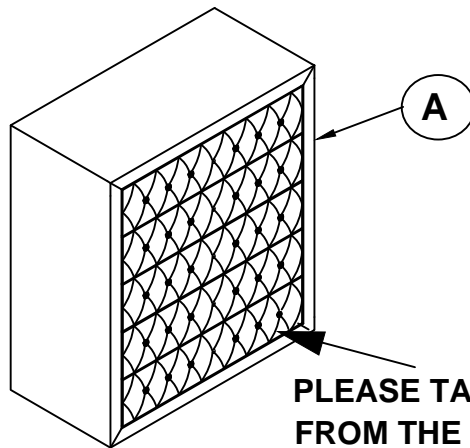

STEP 2

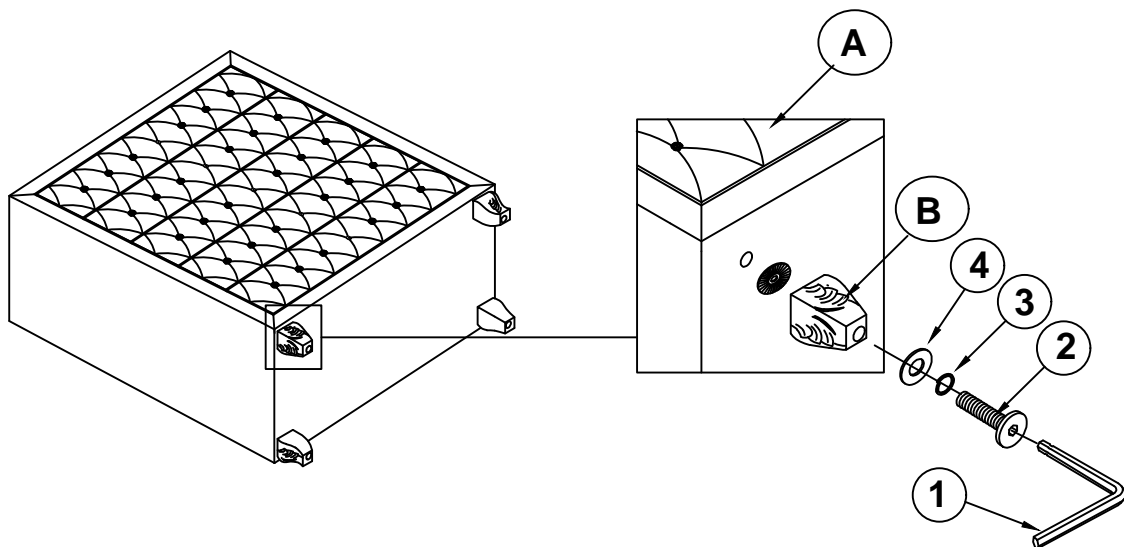

ITEM: **206105**



ASSEMBLY INSTRUCTIONS

STEP 3

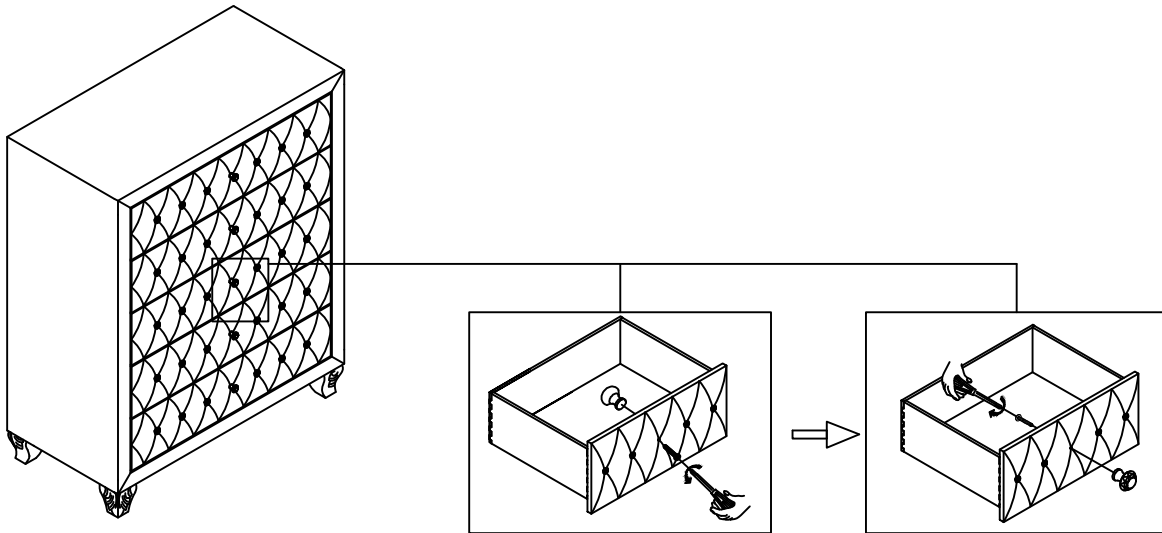

STEP 4 COMPLETE

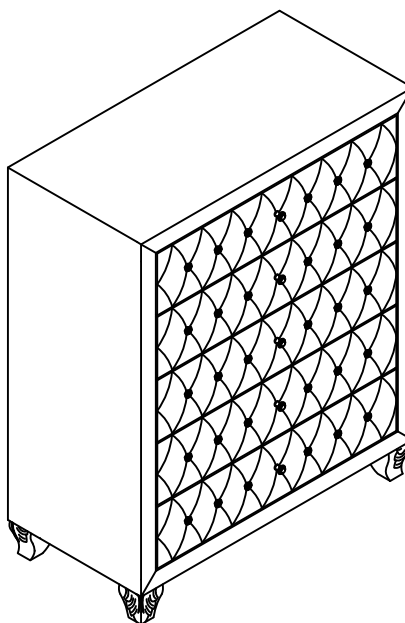

ITEM: **206105**



ANTI-TIPPING INSTALLMENT INSTRUCTIONS

FURNITURE TIPPING RESTRAINT

WARNING

Injury may result from tipping furniture.
This restraint may protect against tipping furniture.
Do not allow children to climb on furniture.
This restraint is not a substitute for proper adult supervision.
Failure to detach this restraint before moving the furniture may result in injury and damage.

1. Attach one of the mounting brackets securely to the back edge of the furniture. Use the short screw.
2. Determine where the furniture is to be placed and mark location on the wall for the mounting bracket screw hole approximately 2" below the bracket mounted to the edge of the furniture.
3. Drill a 3/16" hole in the wall. Press the plastic wall plug into the hole and gently tap until the flange on the wall plug is against the wall surface.
4. Position the bracket over the wall plug and use the long screw to securely attach the bracket to the wall.
5. Place the furniture so the bracket on the back edge is in line with the bracket on the wall.
6. Lace an end of the cable tie down through each bracket. Bring both ends together and slide the beaded end of the cable tie through the keyhole shaped slot on the other end until snug. Pull down on the beaded end until it snap locks into the keyhole slot.
7. To double lock return the beaded end back through the keyhole as shown.
8. Check to make sure the cable tie is securely laced and locked to the brackets.

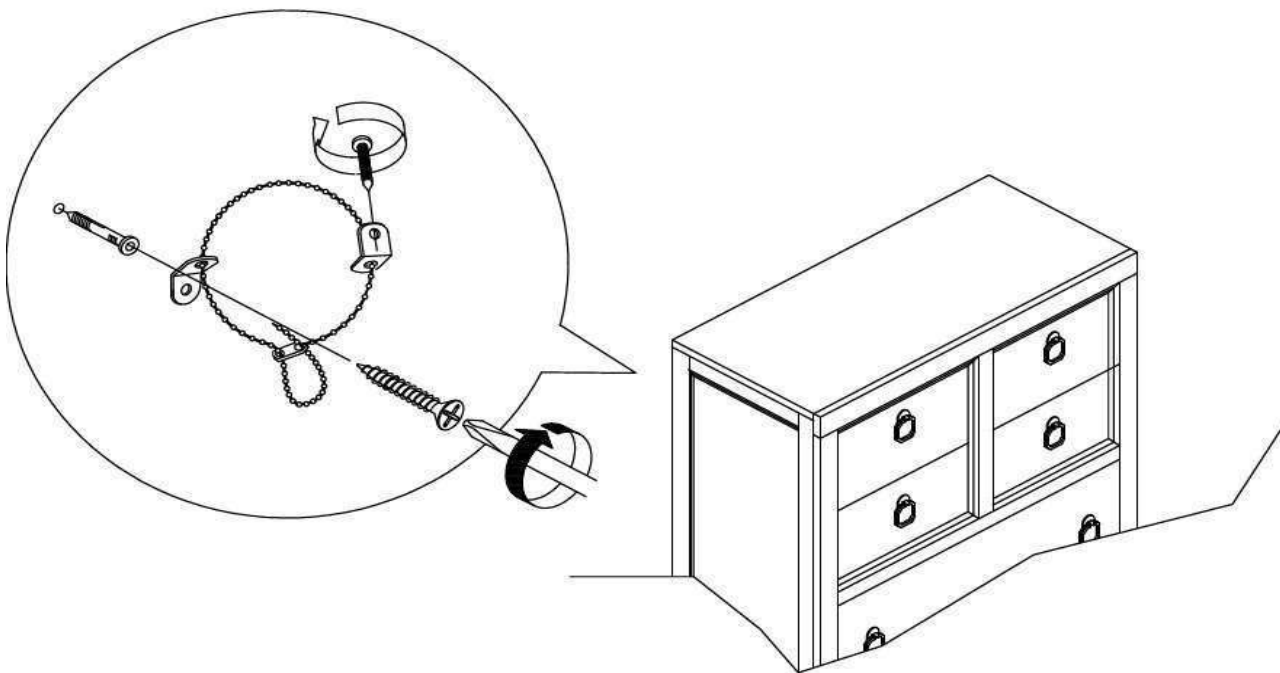

ITEM: **206105**



Inner Size of Drawer : 33.50"W X 14.75"D X 4.50"H X 0.25"T

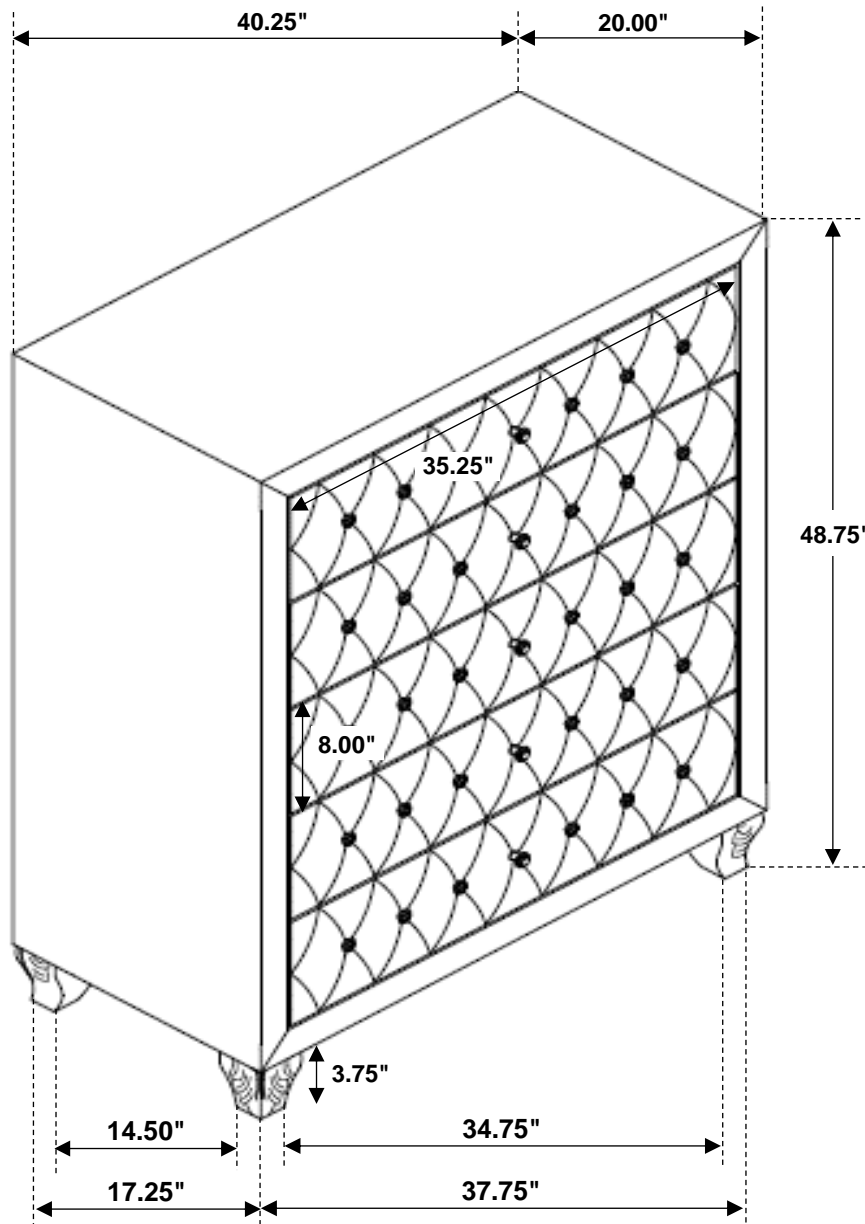

Note: Dimension tolerance $\pm 5\%$