

*ASSEMBLY INSTRUCTIONS*  
*COASTER FINE FURNITURE*

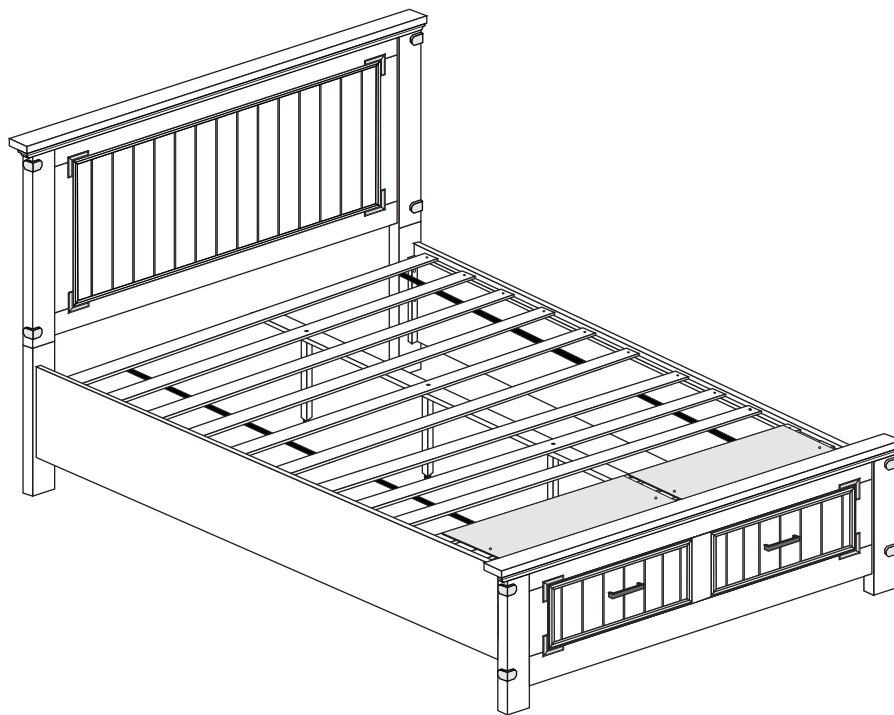

*Fine Furniture for every stage of life*

**205260Q (B1-B3)**  
**Queen Storage Bed**

REVISION 0:07/27/2016  
REVISION 1:11/20/2018  
REVISION 2:11/08/2019

COASTERFURNITURE.COM

# ITEM: 205260Q(B1-B3)



## ASSEMBLY INSTRUCTIONS

### ASSEMBLY TIPS:

- 1 . Remove hardware from box and sort by size.
- 2 . Please check to see that all hardware and parts are present prior to start of assembly.
- 3 . Please follow attached instructions in the same sequence as numbered to assure fast & easy assembly.



### WARNING!

- 1 . Don't attempt to repair or modify parts that are broken or defective. Please contact the store immediately.
- 2 . This product is for home use only and not intended for commercial establishments.

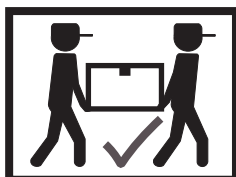

ASSEMBLY TIME

40 MINUTES

## PARTS IDENTIFICATION

### B1 (BOX 1)

A	HEADBOARD PANEL		1PC
B	RIGHT HEADBOARD LEG		1PC
C	LEFT HEADBOARD LEG		1PC
D	WOOD CLEAT		2PCS

### B2 (BOX 2)

E	STORAGE FOOTBOARD		1PC
---	-------------------	--	-----

### B3 (BOX 3)

F	BED RAIL		2PCS
G	HEADBOARD ROLL SLAT (6PCS)		1SET
H	FOOTBOARD ROLL SLAT (6PCS)		1SET
I	CENTER RAIL		1PC
J	CENTER RAIL SUPPORT WITH LEVELER ( WITHOUT HOLE)		3PCS
K	CENTER RAIL SUPPORT WITH LEVELER ( WITH HOLE)		1PC
L	CONCEAL PANEL		2PCS
HB	205260Q (B1) FROM BOX 1 HEADBOARD COMPLETE		1PC
E	205260Q (B2) FROM BOX 2 STORAGE FOOTBOARD		1PC

# ITEM: 205260Q(B1-B3)



## ASSEMBLY INSTRUCTIONS

### ASSEMBLY TIPS:

- 1 . Remove hardware from box and sort by size.
- 2 . Please check to see that all hardware and parts are present prior to start of assembly.
- 3 . Please follow attached instructions in the same sequence as numbered to assure fast & easy assembly.











### WARNING!

- 1 . Don't attempt to repair or modify parts that are broken or defective. Please contact the store immediately.
- 2 . This product is for home use only and not intended for commercial establishments.

## HARDWARE IDENTIFICATION

### Z-B3 (BOX 3) - HARDWARE PACK IS LOCATED IN 205260Q (B3)

1	<b>LONG BOLT</b> (M6 x 50mm - RBW)		16PCS
2	<b>SHORT BOLT</b> (M6 x 40mm - RBW)		12PCS
3	<b>BIG FLAT WASHER</b> (M6 x 19mm - RBW)		12PCS
4	<b>SMALL FLAT WASHER</b> (M6 x 13mm - RBW)		12PCS
5	<b>LOCK WASHER</b> (M6 x 13mm - RBW)		24PCS
6	<b>LONG FLAT HEAD SCREW</b> (M4 x 30mm - RBW)		25PCS
7	<b>SHORT FLAT HEAD SCREW</b> (M4 x 16mm - RBW)		8PCS
8	<b>ALLEN WRENCH</b> (M4 x 58mm- BLK)		1PC
9	<b>WOOD DOWEL</b> (O/10 x 30mm)		8PCS

### NOTE :

Phillips head screw driver is required in the assembly process; however, manufacturer does not provide this item.

# ITEM: 205260Q(B1-B3)

## ASSEMBLY INSTRUCTIONS



### STEP 1

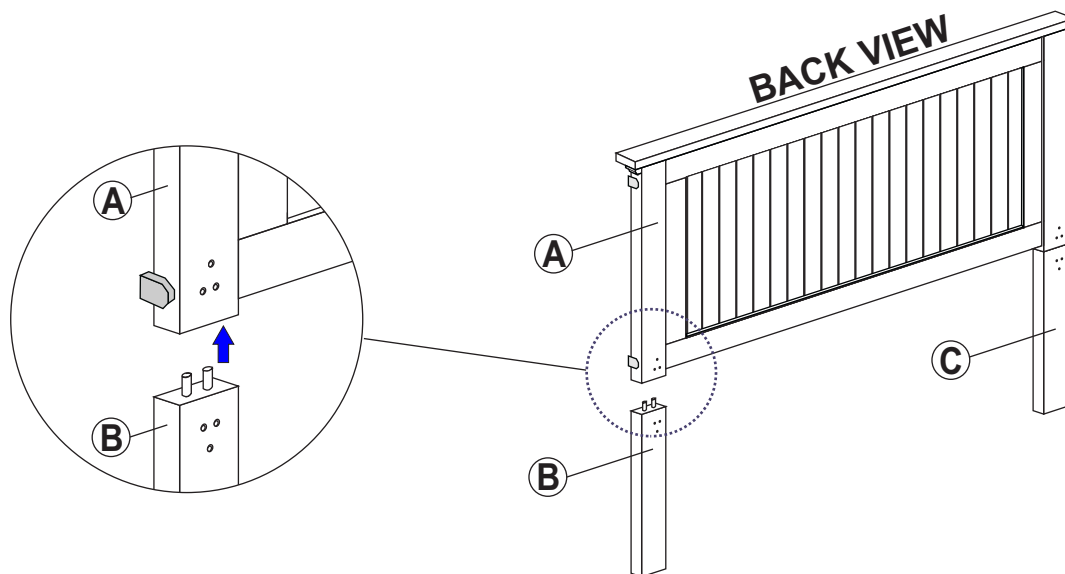

### STEP 2

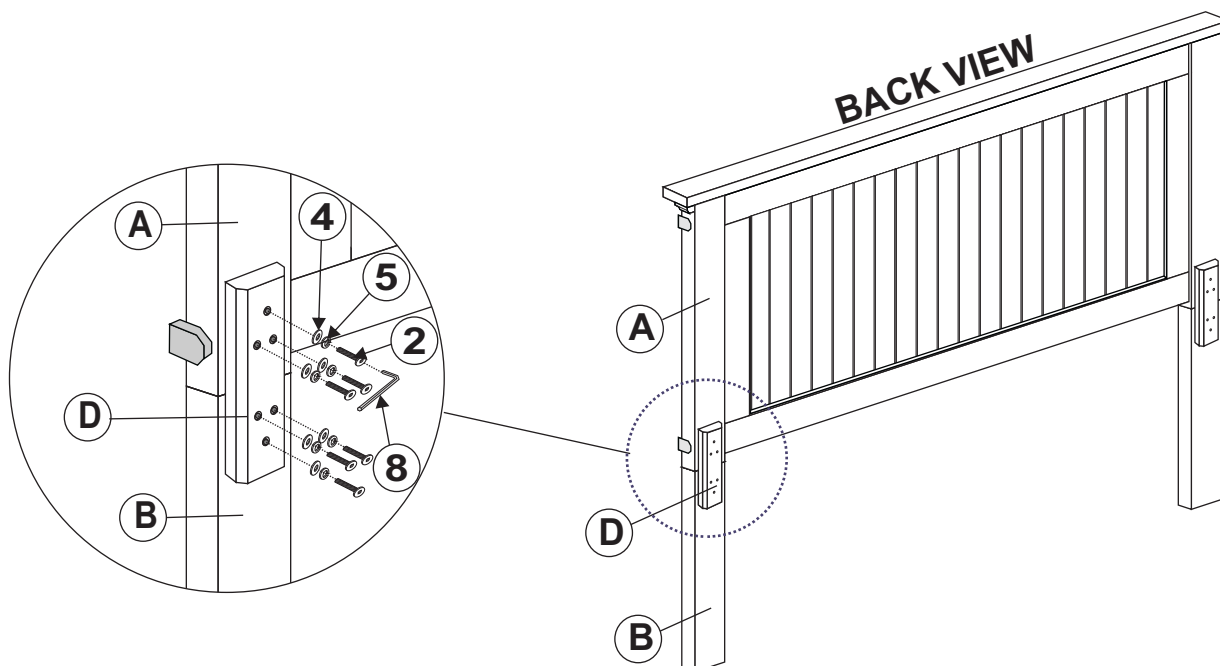

# ITEM: 205260Q(B1-B3)

## ASSEMBLY INSTRUCTIONS



### STEP 3

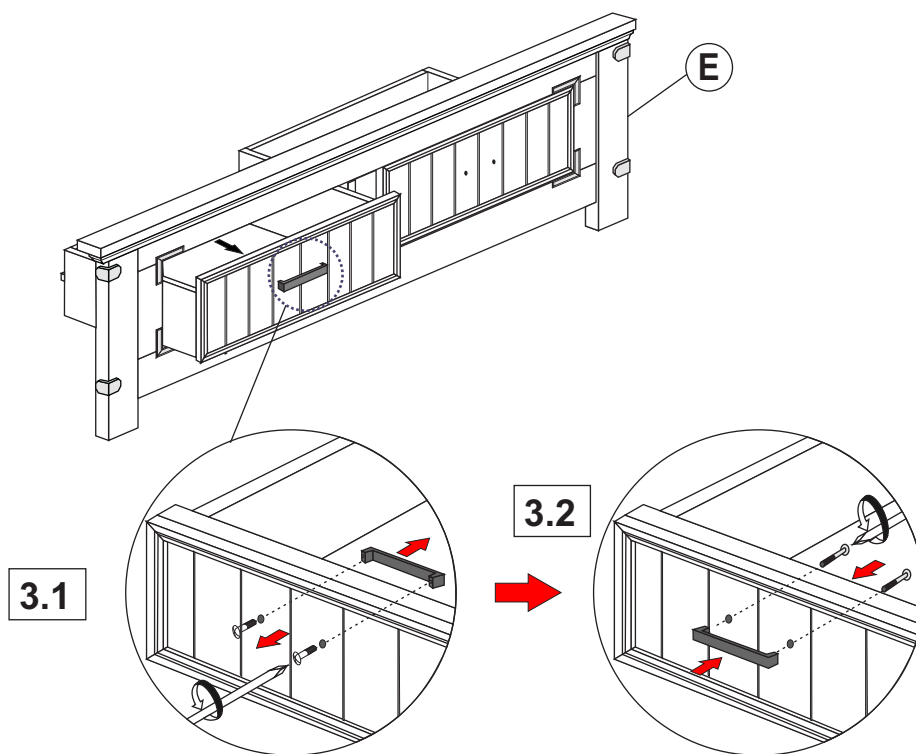

### STEP 4

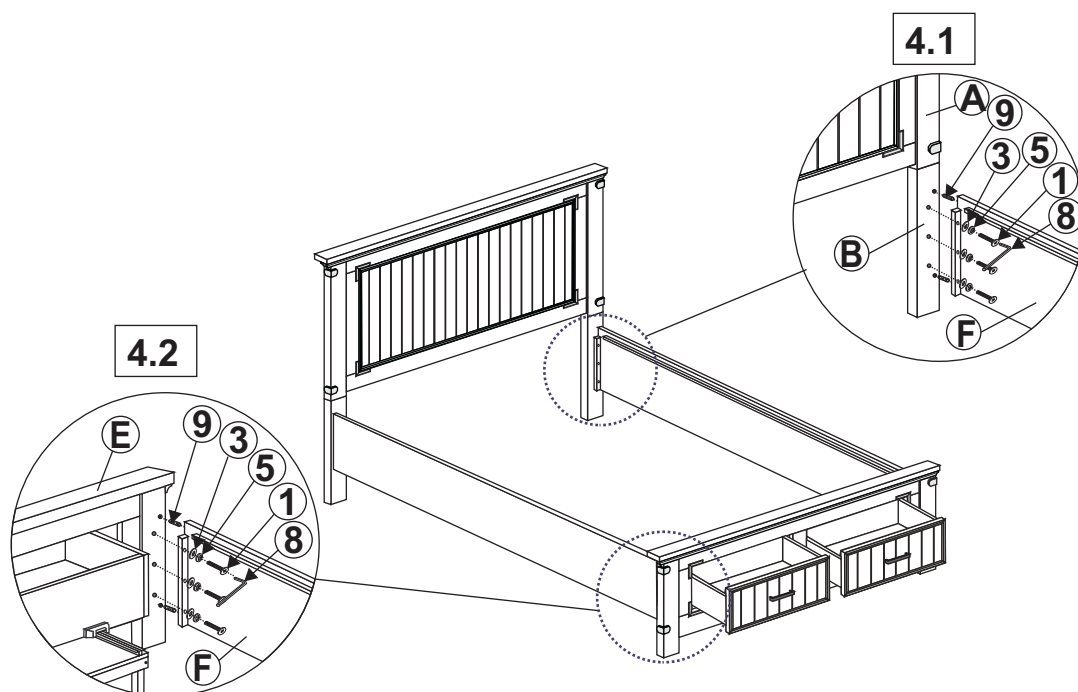

# ITEM: 205260Q(B1-B3)

## ASSEMBLY INSTRUCTIONS



### STEP 5

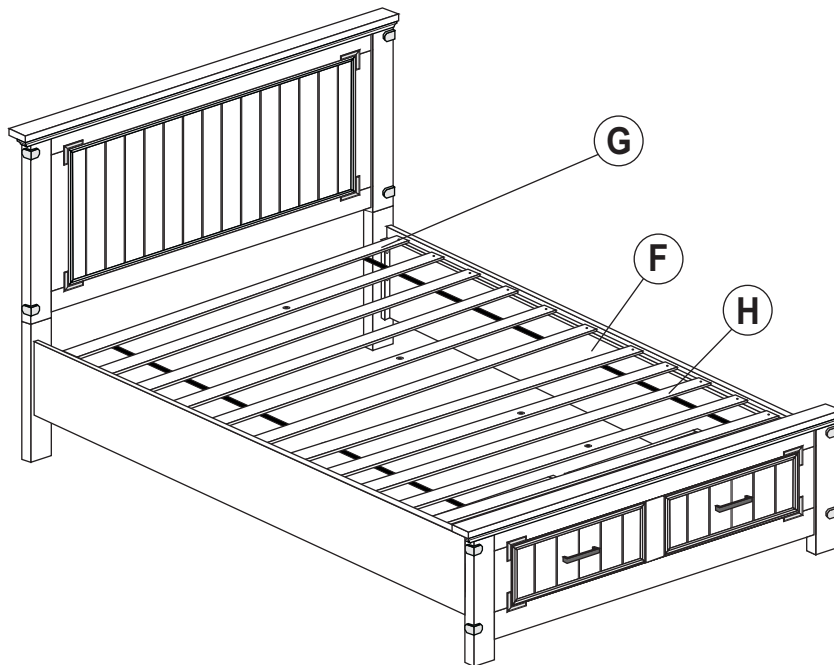

### STEP 6

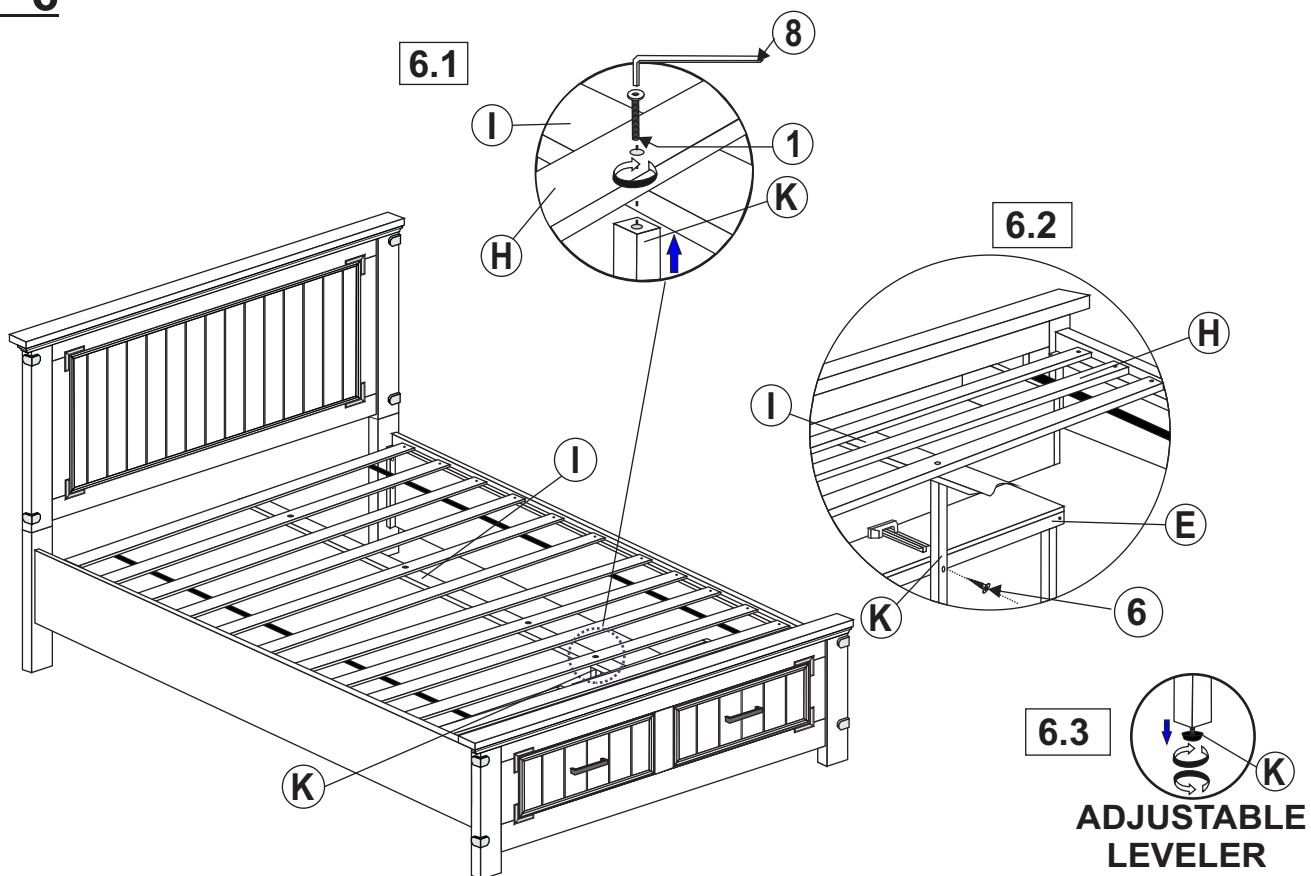

# ITEM: 205260Q(B1-B3)

## ASSEMBLY INSTRUCTIONS



### STEP 7

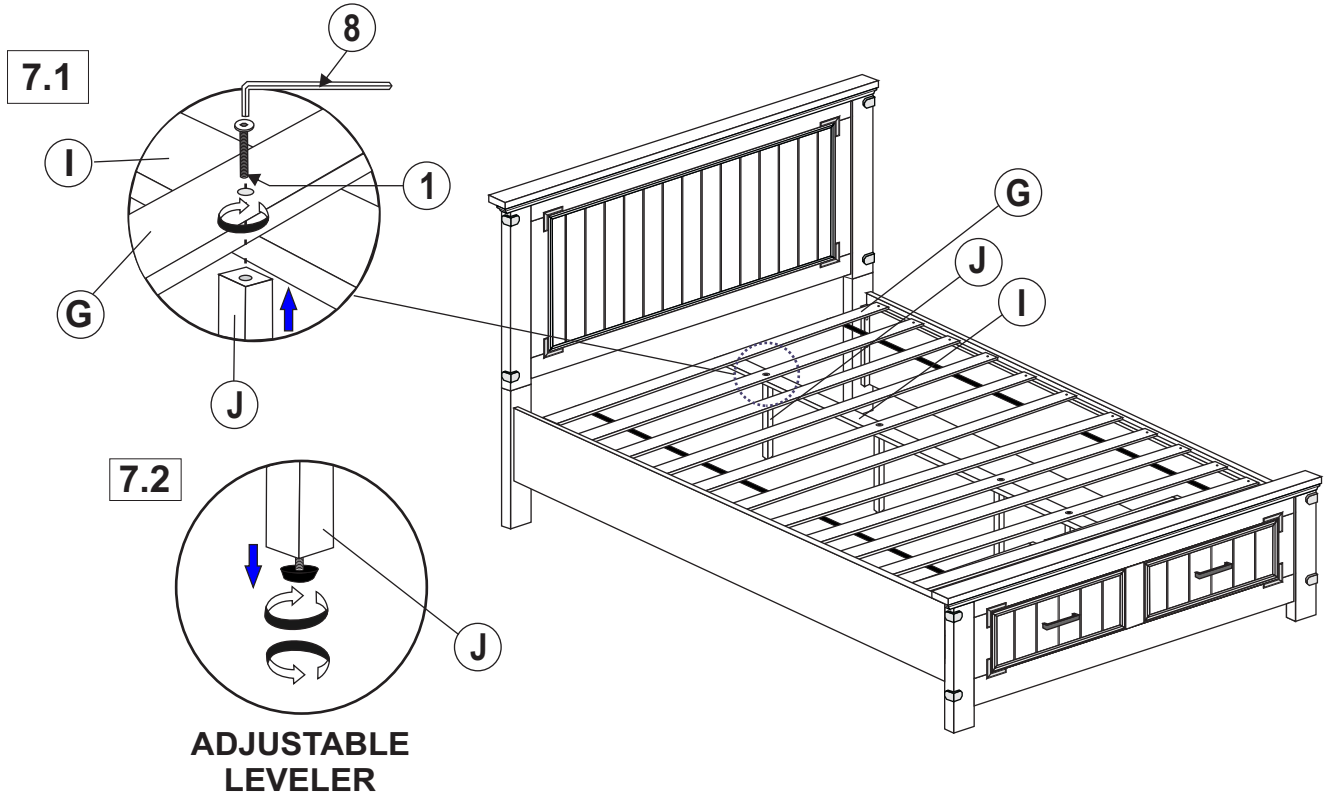

### STEP 8

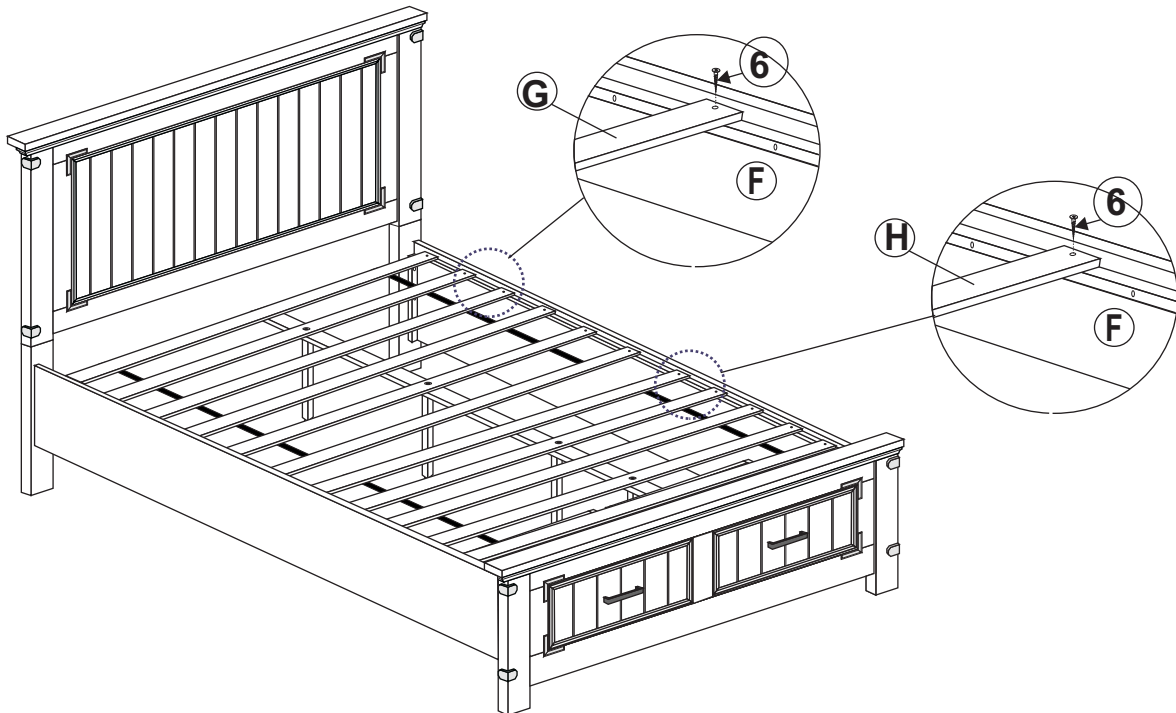

ITEM: **205260Q(B1-B3)**

**ASSEMBLY INSTRUCTIONS**



**STEP 9**

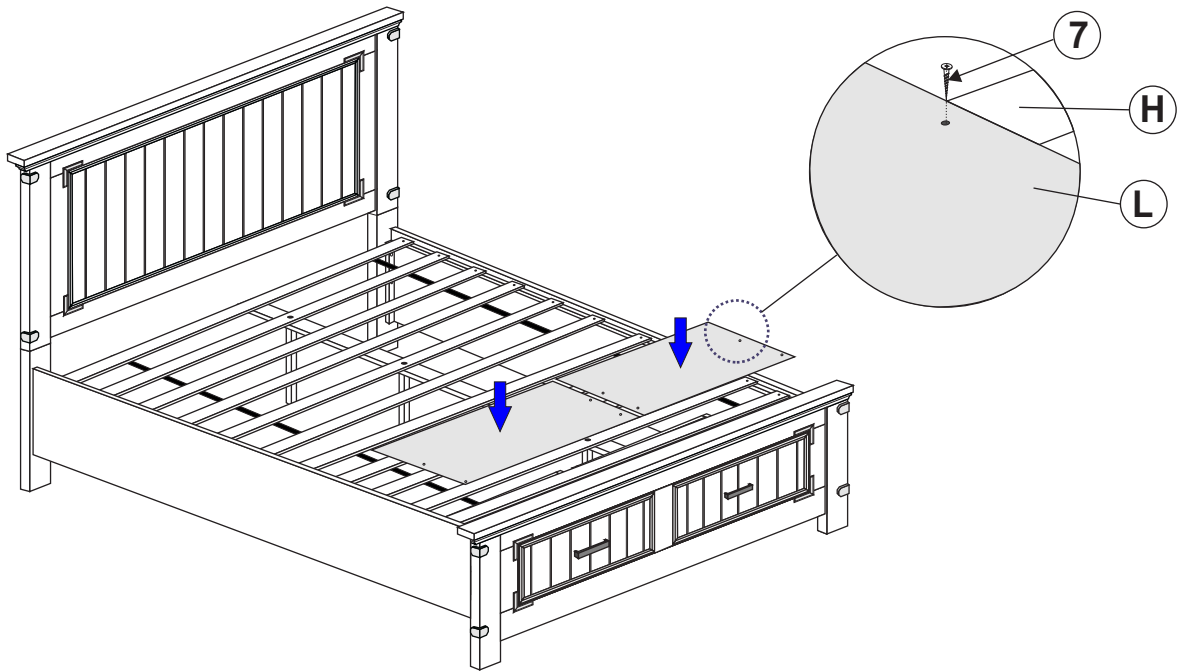

**STEP 10**  
**COMPLETE**

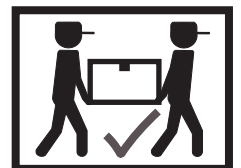
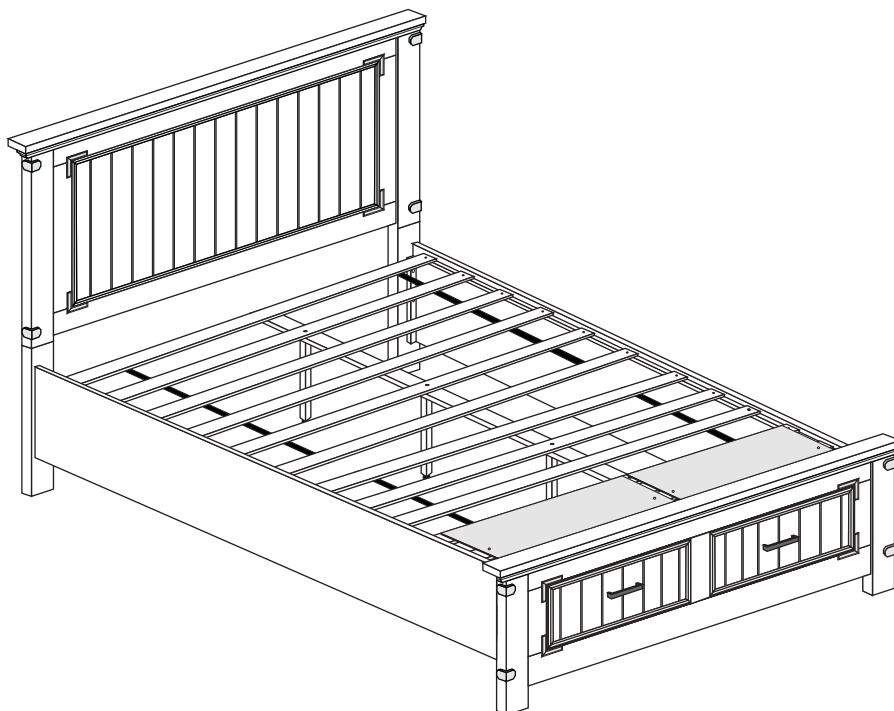

# ITEM: 205260Q(B1-B3)



Inner Size : 60.50"W X 81.00"D  
Inner Size of Drawer : 19.25"W X 13.50"D X 7.25"H X 0.50"T

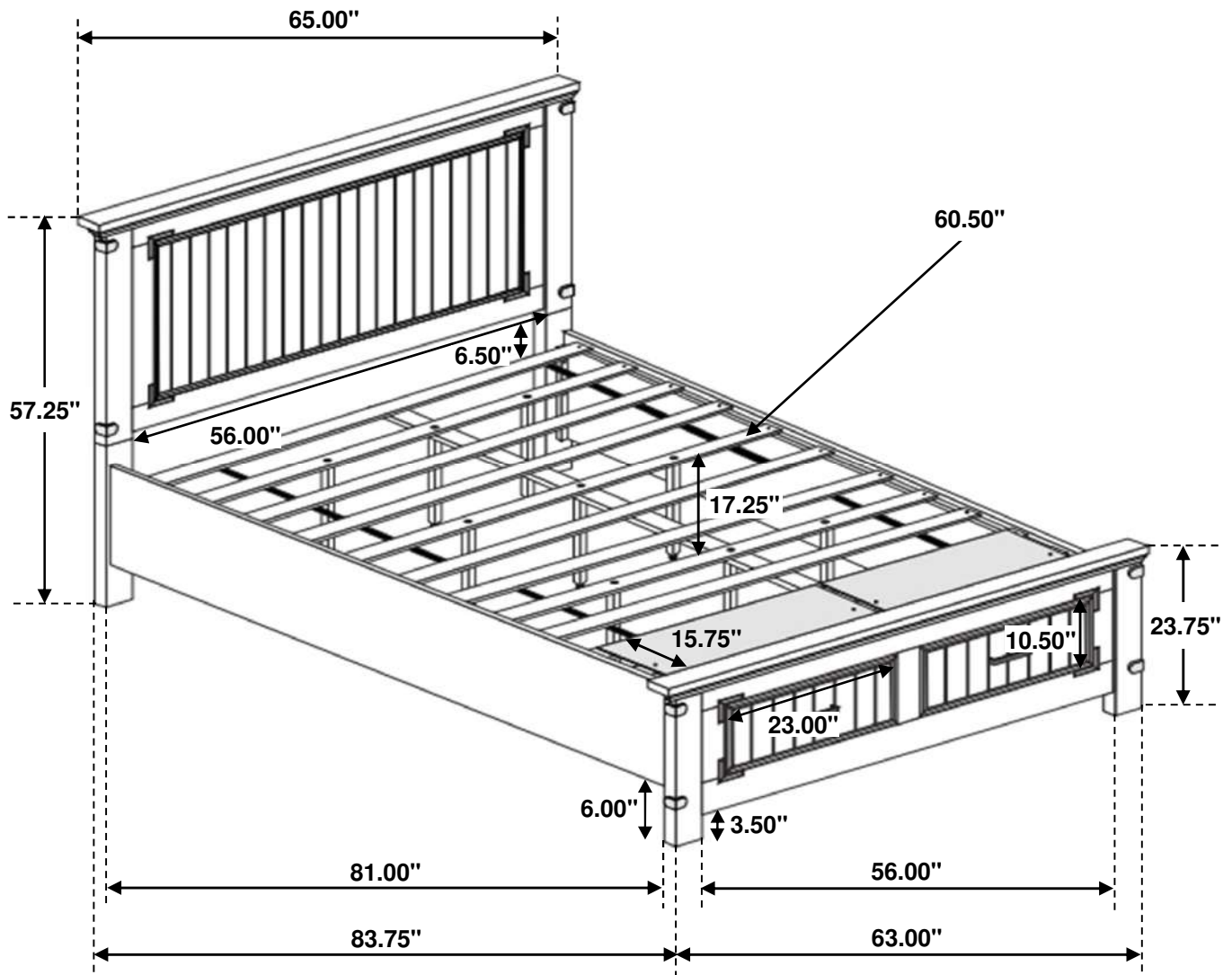

Note : Dimension tolerance  $\pm 5\%$