

ASSEMBLY INSTRUCTIONS
COASTER FINE FURNITURE

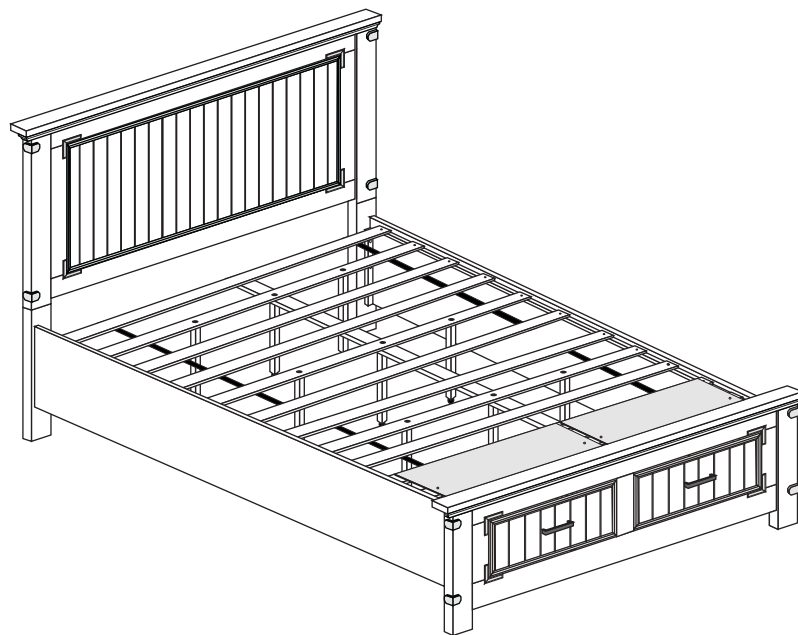

Fine Furniture for every stage of life

205260F (B1-B3)
Full Storage Bed

REVISION 0:07/27/2016
REVISION 1:11/20/2018
REVISION 2:11/08/2019
REVISION 3:06/01/2022

COASTERFURNITURE.COM

ITEM: 205260F(B1-B3)



ASSEMBLY INSTRUCTIONS

ASSEMBLY TIPS:

- 1 . Remove hardware from box and sort by size.
- 2 . Please check to see that all hardware and parts are present prior to start of assembly.
- 3 . Please follow attached instructions in the same sequence as numbered to assure fast & easy assembly.



WARNING!

- 1 . Don't attempt to repair or modify parts that are broken or defective. Please contact the store immediately.
- 2 . This product is for home use only and not intended for commercial establishments.

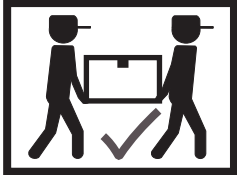

ASSEMBLY TIME

40 MINUTES

PARTS IDENTIFICATION

B1 (BOX 1)

A	HEADBOARD PANEL		1PC
B	RIGHT HEADBOARD LEG		1PC
C	LEFT HEADBOARD LEG		1PC
D	WOOD CLEAT		2PCS

B2 (BOX 2)

E	STORAGE FOOTBOARD		1PC
---	-------------------	--	-----

B3 (BOX 3)

F	BED RAIL		2PCS
G	HEADBOARD ROLL SLAT (6PCS)		1SET
H	FOOTBOARD ROLL SLAT (6PCS)		1SET
I	CENTER RAIL		1PC
J	CENTER RAIL SUPPORT WITH LEVELER (WITHOUT HOLE)		3PCS
K	CENTER RAIL SUPPORT WITH LEVELER (WITH HOLE)		1PC
L	CONCEAL PANEL		2PCS
HB	205260F (B1) FROM BOX 1 HEADBOARD COMPLETE		1PC
E	205260F (B2) FROM BOX 2 STORAGE FOOTBOARD		1PC

ITEM: 205260F(B1-B3)



ASSEMBLY INSTRUCTIONS

ASSEMBLY TIPS:

- 1 . Remove hardware from box and sort by size.
- 2 . Please check to see that all hardware and parts are present prior to start of assembly.
- 3 . Please follow attached instructions in the same sequence as numbered to assure fast & easy assembly.











WARNING!

- 1 . Don't attempt to repair or modify parts that are broken or defective. Please contact the store immediately.
- 2 . This product is for home use only and not intended for commercial establishments.

HARDWARE IDENTIFICATION

Z-B3 (BOX 3) - HARDWARE PACK IS LOCATED IN 205260F (B3)

1	LONG BOLT (M6 x 50mm - RBW)		16PCS
2	SHORT BOLT (M6 x 40mm - RBW)		12PCS
3	BIG FLAT WASHER (M6 x 19mm - RBW)		12PCS
4	SMALL FLAT WASHER (M6 x 13mm - RBW)		12PCS
5	LOCK WASHER (M6 x 13mm - RBW)		24PCS
6	LONG FLAT HEAD SCREW (M4 x 30mm - BLK)		25PCS
7	SHORT FLAT HEAD SCREW (M4 x 16mm - RBW)		8PCS
8	ALLEN WRENCH (M4 x 58mm- BLK)		1PC
9	WOOD DOWEL (Ø 10 x 30mm)		8PCS

NOTE :

Phillips head screw driver is required in the assembly process; however, manufacturer does not provide this item.

ITEM: 205260F(B1-B3)

ASSEMBLY INSTRUCTIONS



STEP 1

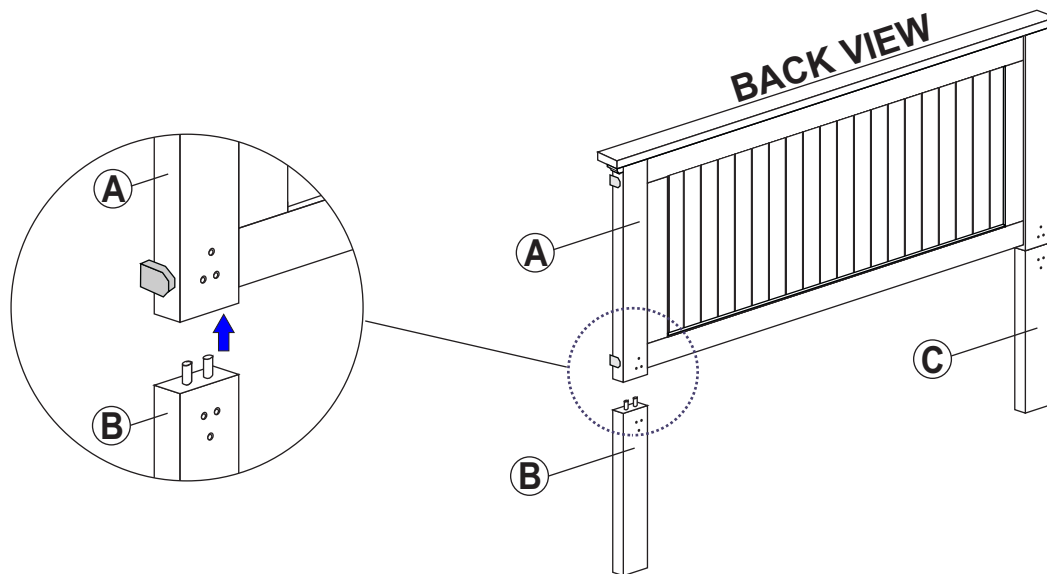

STEP 2

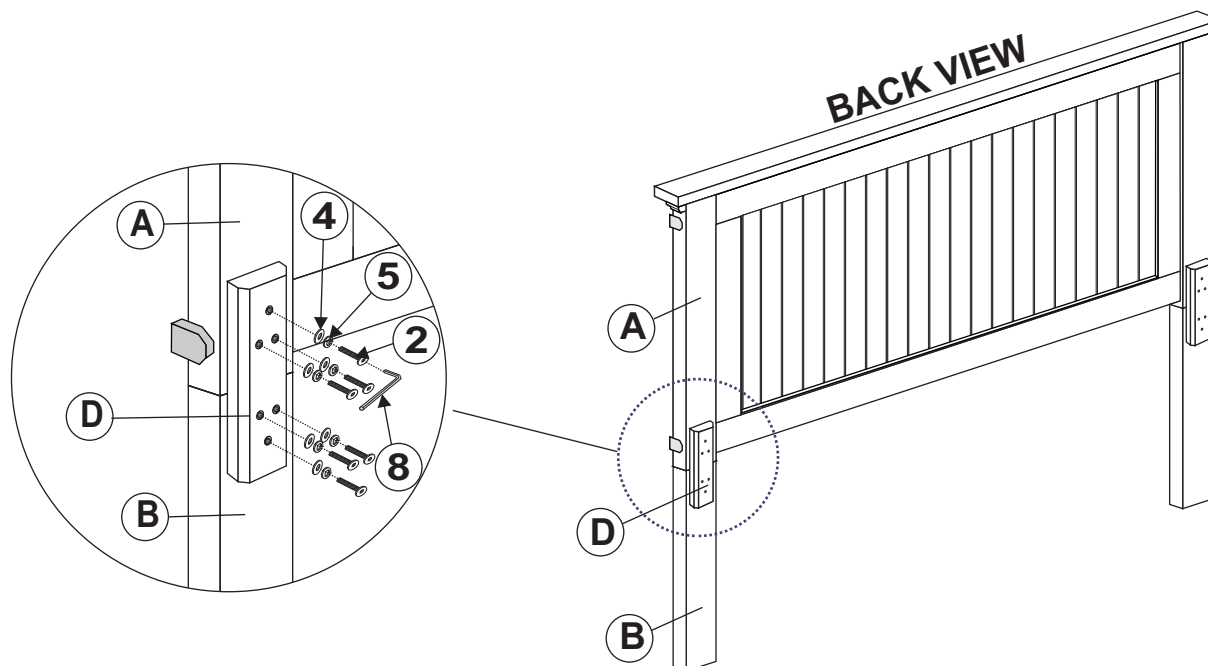

ITEM: 205260F(B1-B3)

ASSEMBLY INSTRUCTIONS



STEP 3

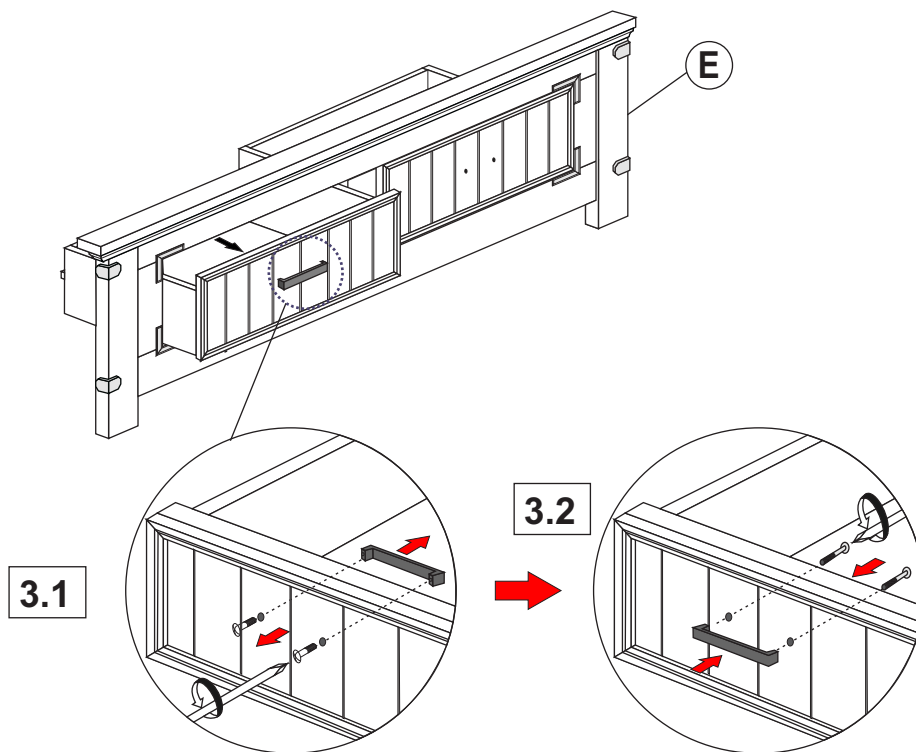

STEP 4

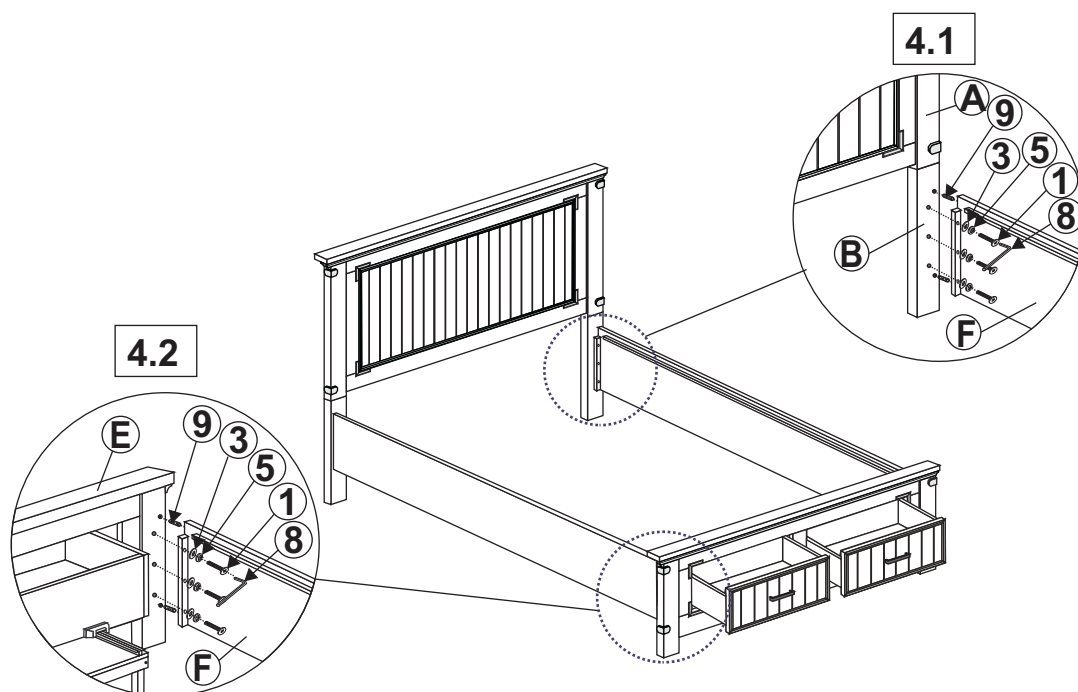

ITEM: 205260F(B1-B3)

ASSEMBLY INSTRUCTIONS



STEP 5

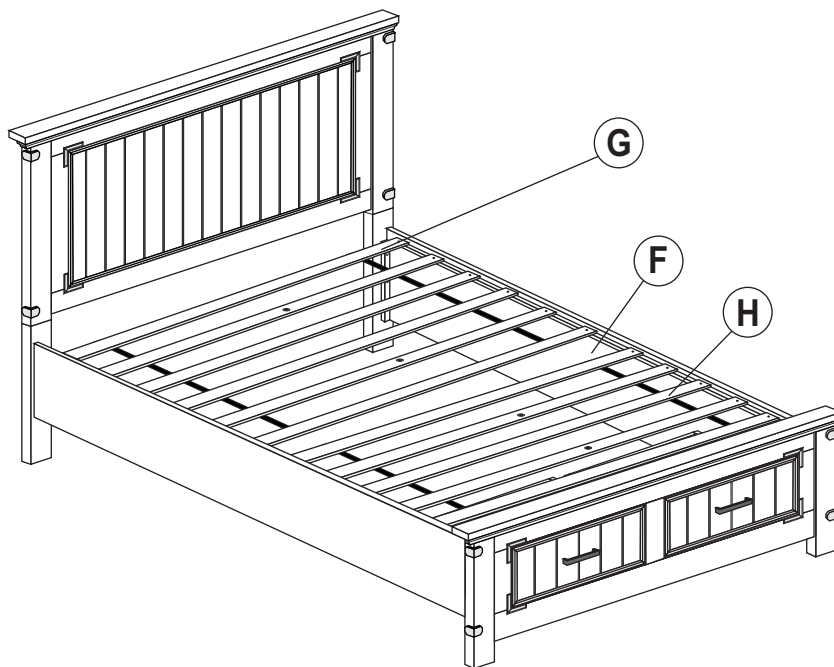

STEP 6

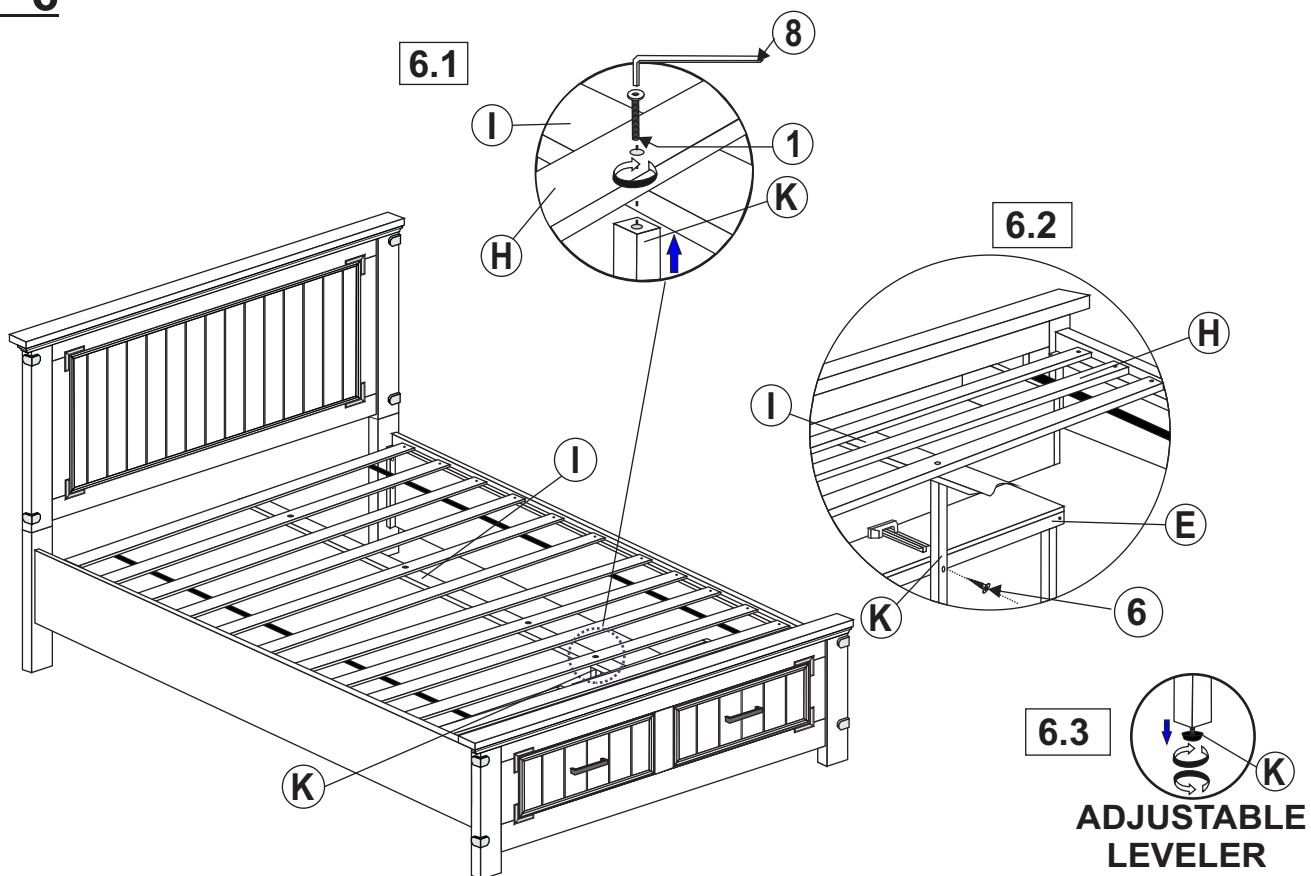

STEP 7

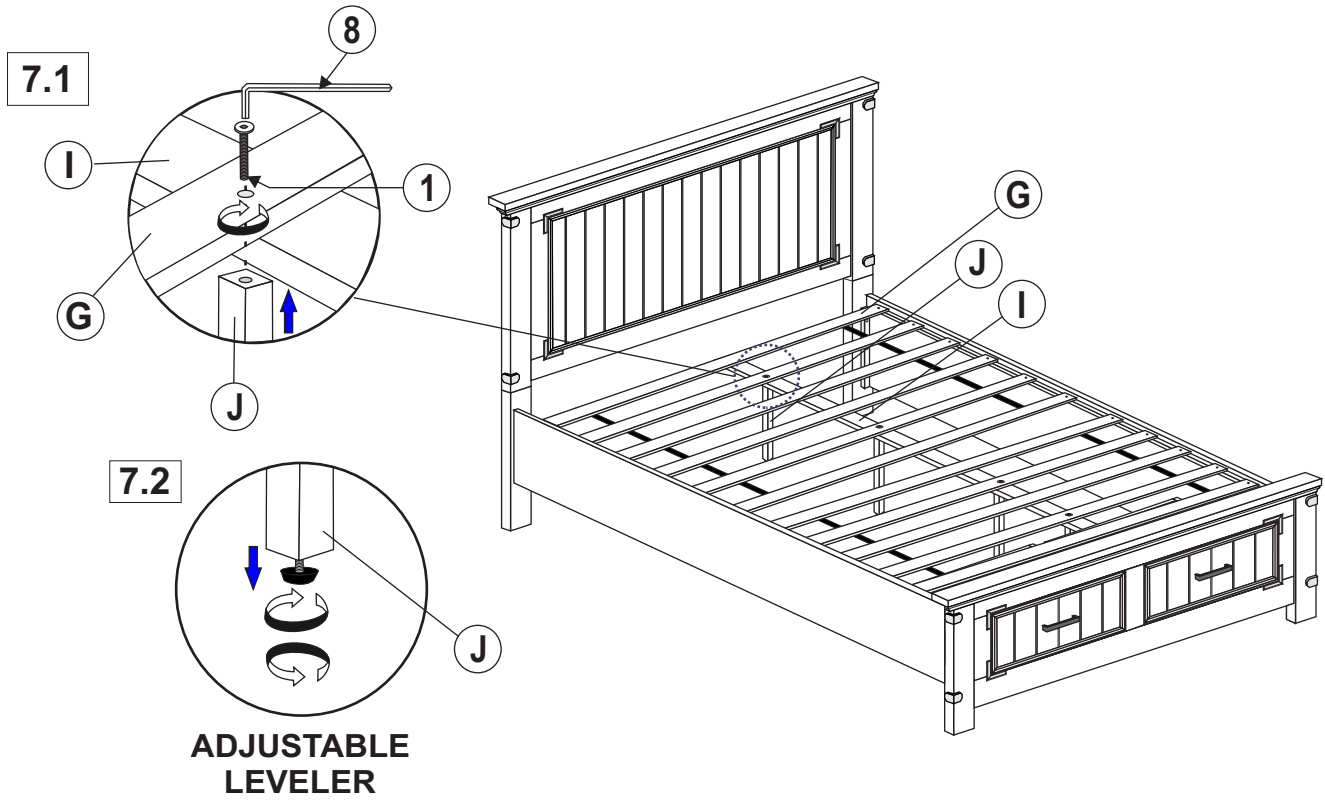

STEP 8

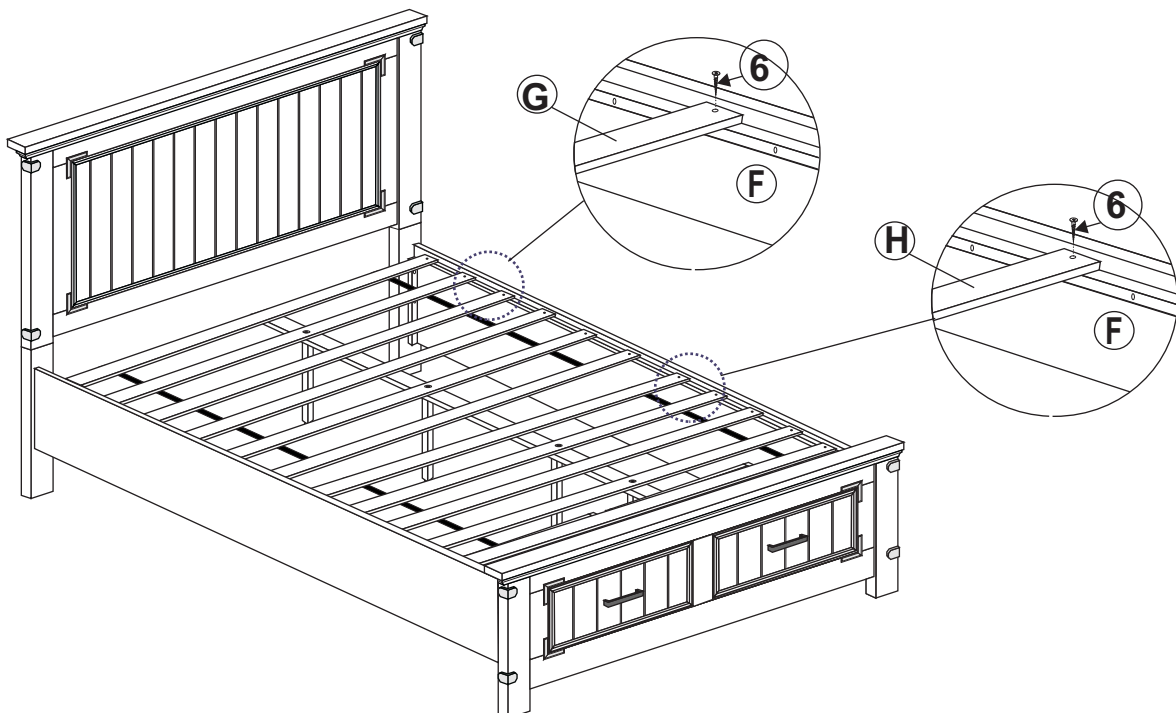

ITEM: **205260F(B1-B3)**

ASSEMBLY INSTRUCTIONS



STEP 9

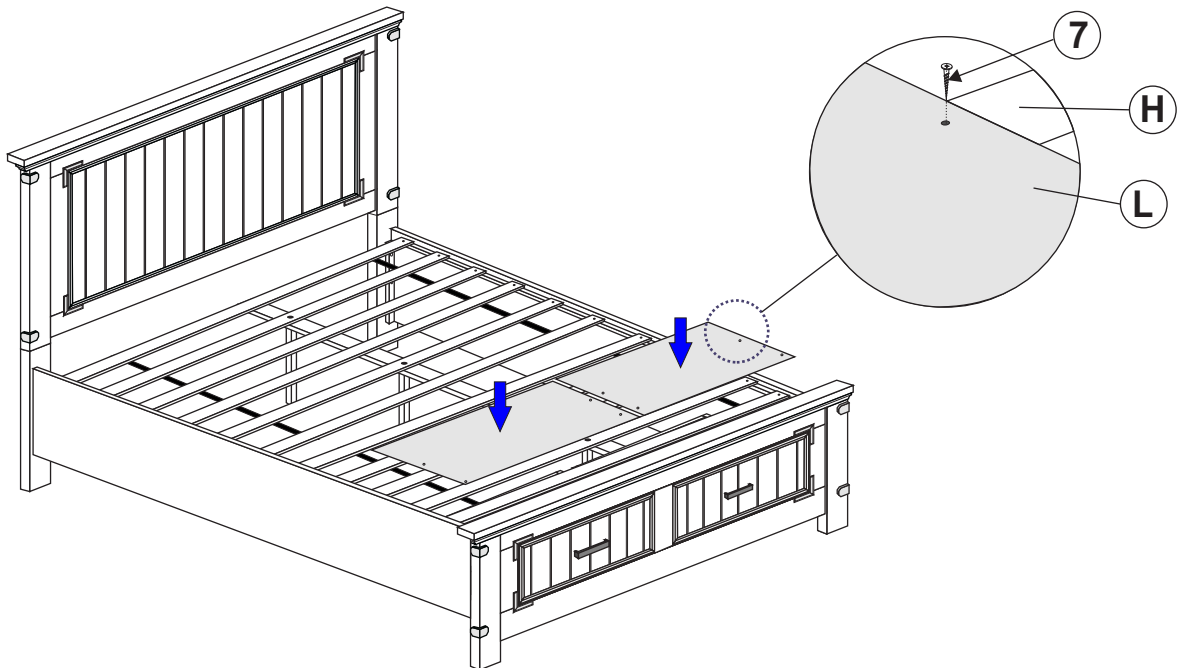

STEP 10
COMPLETE

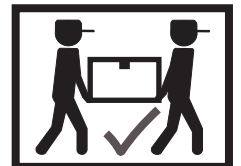
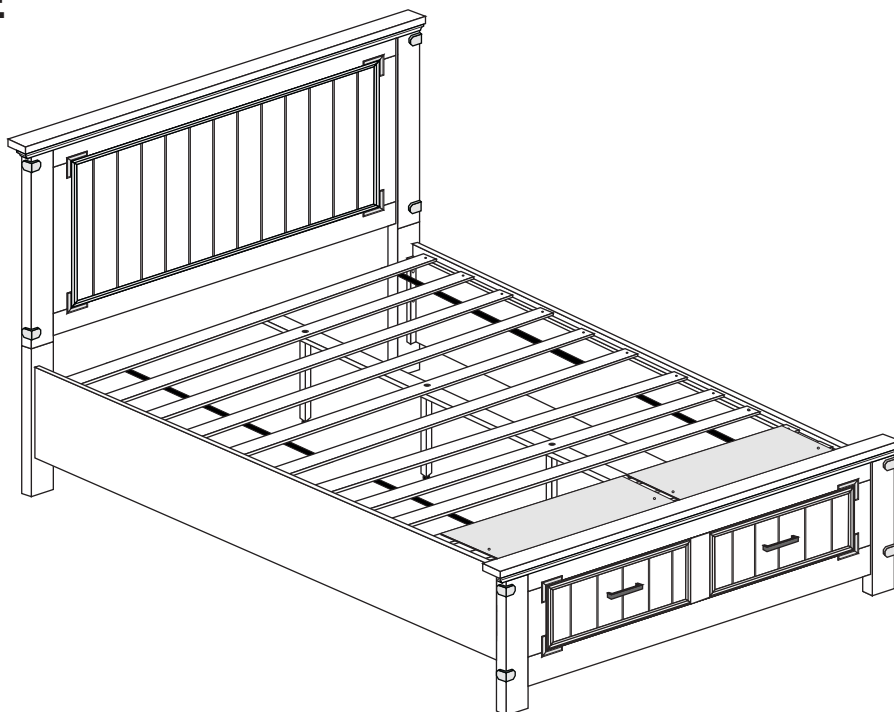

ITEM: 205260F(B1-B3)

ASSEMBLY INSTRUCTIONS



Inner Size : 54.75"W X 76.00"D
Inner Size of Drawer : 16.25"W X 13.50"D X 7.25"H X 0.50"T

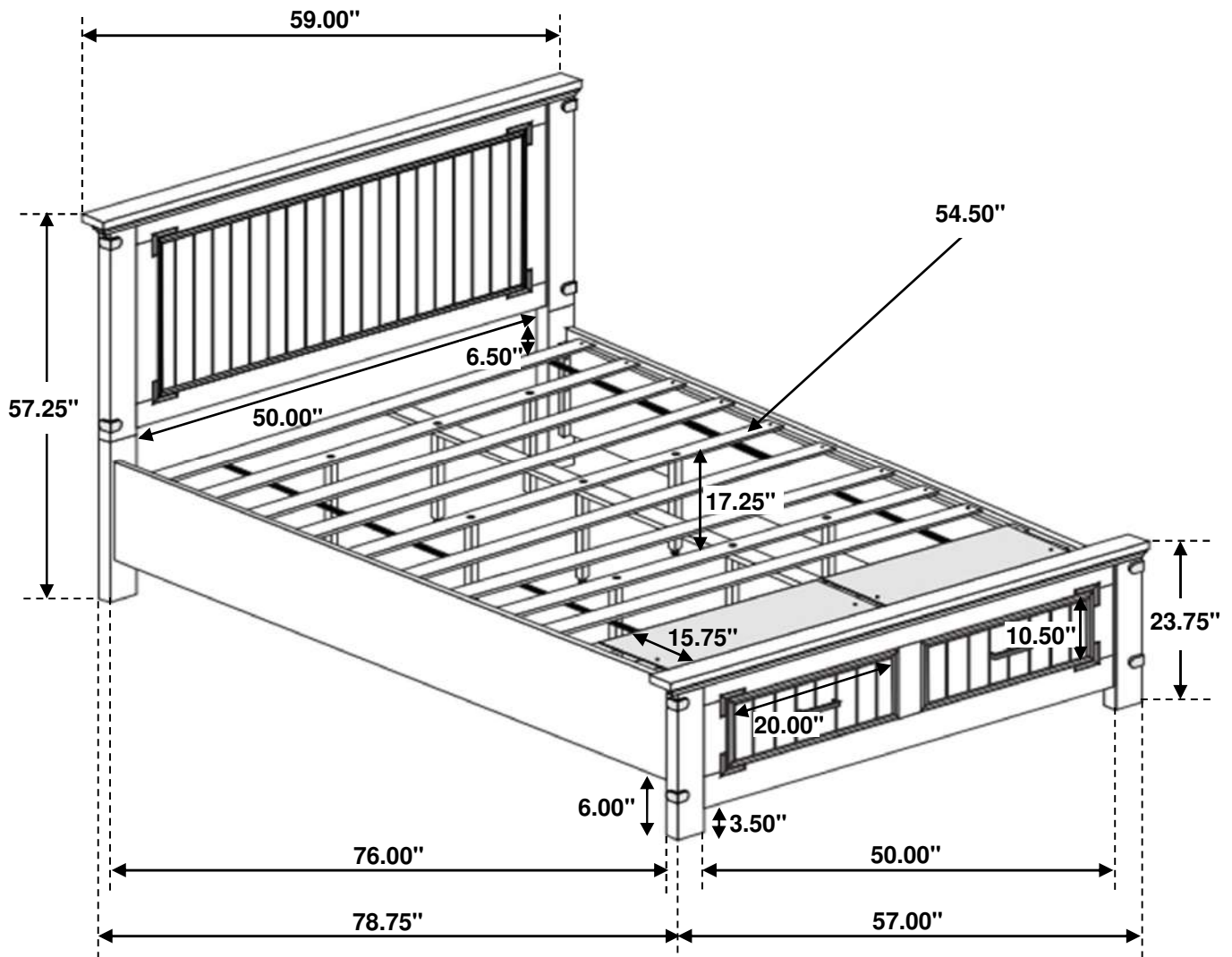

Note : Dimension tolerance $\pm 5\%$