

ASSEMBLY INSTRUCTIONS
COASTER FINE FURNITURE

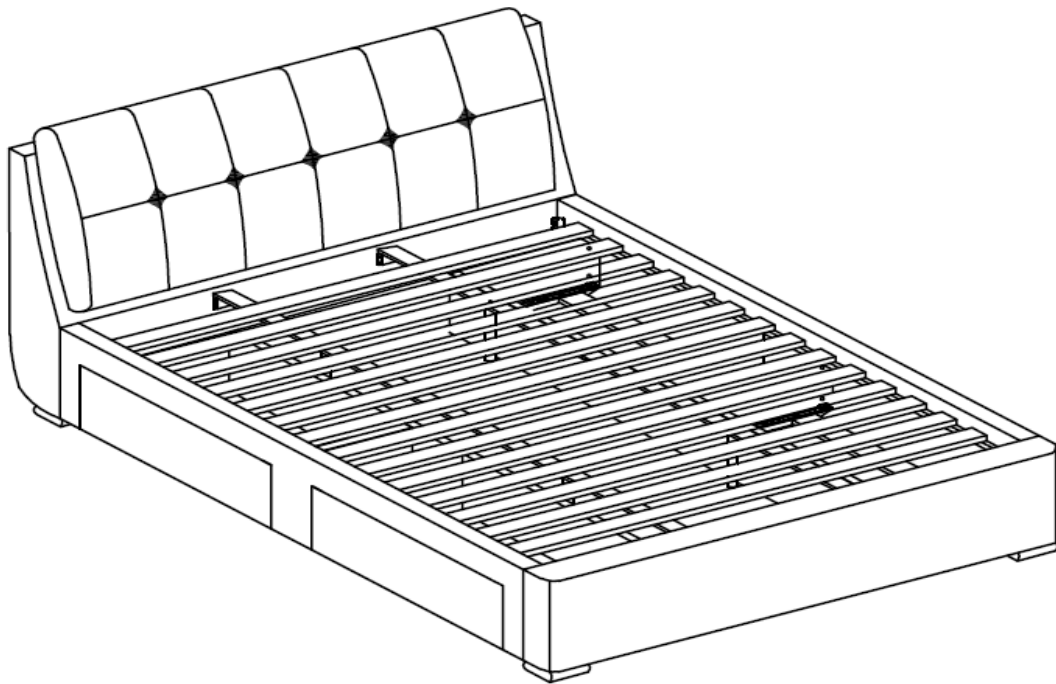

Fine Furniture for every stage of life

300523KW (B1-B5)
California King Storage Bed

REVISION 0 : 11/30/2015
REVISION 1 : 12/28/2015
REVISION 2 : 06/09/2016
REVISION 3 : 08/20/2016
REVISION 4 : 09/26/2016
REVISION 5 : 07/17/2019

ITEM: 300523KW (B1-B5)



ASSEMBLY INSTRUCTIONS

ASSEMBLY TIPS:

1. Remove hardware from box and sort by size.
2. Please check to see that all hardware and parts are present prior to start of assembly.
3. Please follow attached instructions in the same sequence as numbered to assure fast & easy assembly.



WARNING!

1. Don't attempt to repair or modify parts that are broken or defective. Please contact the store immediately.
2. This product is for home use only and not intended for commercial establishments.



ASSEMBLY TIME

90 MINUTES

PARTS IDENTIFICATION

B1 (BOX 1)

A HEADBOARD
PANEL

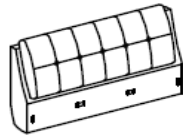

1PC

B2 (BOX 2)

B FOOTBOARD
PANEL



1PC

B3 (BOX 3)

C BED RAIL

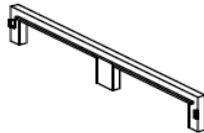

2PCS

D HEADBOARD &
FOOTBOARD
LEG

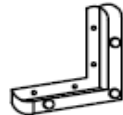

4PCS

E CENTER RAIL



2PCS

F BED SLAT
SUPPORT WITH
LEVELER



4PCS

H DRAWER FRONT
PANEL (WITH "1"
LABEL)



4PCS

NOTE:

Phillips head screw driver is required in the assembly process; however, manufacturer does not provide this item.

ITEM: 300523KW (B1-B5)



ASSEMBLY INSTRUCTIONS

ASSEMBLY TIPS:

1. Remove hardware from box and sort by size.
2. Please check to see that all hardware and parts are present prior to start of assembly.
3. Please follow attached instructions in the same sequence as numbered to assure fast & easy assembly.

WARNING!



1. Don't attempt to repair or modify parts that are broken or defective. Please contact the store immediately.
2. This product is for home use only and not intended for commercial establishments.









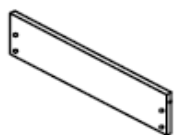

ASSEMBLY TIME

90 MINUTES

PARTS IDENTIFICATION

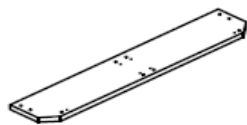
B4 (BOX 4)

G	SET OF GLIDES		8SET
I	DRAWER BACK PANEL (WITH "2" LABEL)		4PCS
J	DRAWER SIDE PANEL (WITH "3" LABEL)		8PCS
K	DRAWER BOTTOM PANEL (WITH "4" LABEL)		4PCS
L	DRAWER SUPPORT BAR (WITH "5" LABEL)		8PCS

M	SIDE FRAME (WITH "6" LABEL)		2PCS
N	SMALL RIGHT CENTER PANEL (WITH "7" LABEL)		2PCS
O	SMALL LEFT CENTER PANEL (WITH "8" LABEL)		2PCS
P	LARGE CENTER FRAME (WITH "9" LABEL)		2PCS
Q	SUPPORT BAR (WITH "10" LABEL)		2PCS

B5 (BOX 5)

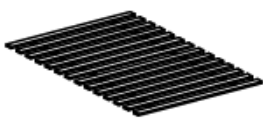
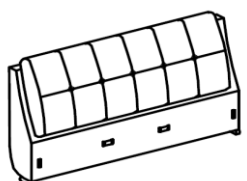
R	ROLL SLAT (14PCS)		1SET
HB	300523KW (B1&B3) *FROM BOX 1 & BOX 3 HEADBOARD COMPLETE		1PC

FB	300523KW (B2&B3) *FROM BOX 2 & BOX 3 FOOTBOARD		1PC
----	---	---	-----

NOTE:

Phillips head screw driver is required in the assembly process; however, manufacturer does not provide this item.

ITEM: 300523KW (B1-B5)

ASSEMBLY INSTRUCTIONS

ASSEMBLY TIPS:

1. Remove hardware from box and sort by size.
2. Please check to see that all hardware and parts are present prior to start of assembly.
3. Please follow attached instructions in the same sequence as numbered to assure fast & easy assembly.







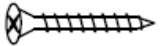

WARNING!

1. Don't attempt to repair or modify parts that are broken or defective. Please contact the store immediately.
2. This product is for home use only and not intended for commercial establishments.

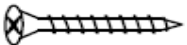
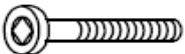
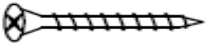
HARDWARE IDENTIFICATION

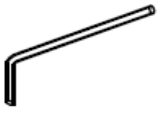
Z-B3 (BOX 3) - HARDWARE PACK IS LOCATED IN 300523KW (B3)

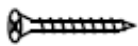
1	PLASTIC DOWEL (4 x 25MM - BLK) (WITH "A" LABEL)		24PCS	7	MEDIUM FLAT HEAD SCREW (CSKM4 X 25MM - RBW) (WITH "G" LABEL)		16PCS
2	SHORT BOLT JCBCW (M6 x 40MM - BLK) (WITH "B" LABEL)		24PCS	8	LONG FLAT HEAD SCREW (CSKM4 X 32MM - RBW) (WITH "H" LABEL)		50PCS
3	LONG BOLT JCBC (M6 x 40MM - RBW) (WITH "C" LABEL)		20PCS	9	LONG FLAT HEAD SCREW (CSKM4 X 50MM - RBW) (WITH "I" LABEL)		32PCS
4	PLASTIC GLIDE (20MM - WHT) (WITH "D" LABEL)		20PCS	10	ALLEN WRENCH (M4 X 65MM-BLK) (WITH "J" LABEL)		1PC
5	NAIL (20MM - RBW) (WITH "E" LABEL)		48PCS	11	LOCK WASHER (20MM- RBW) (WITH "K" LABEL)		16PCS
6	SHORT FLAT HEAD SCREW (CSK3.5 x 16MM- RBW) (WITH "F" LABEL)		48PCS				

NOTE:

Phillips head screw driver is required in the assembly process; however, manufacturer does not provide this item.

ASSEMBLY INSTRUCTIONS

STEP 1

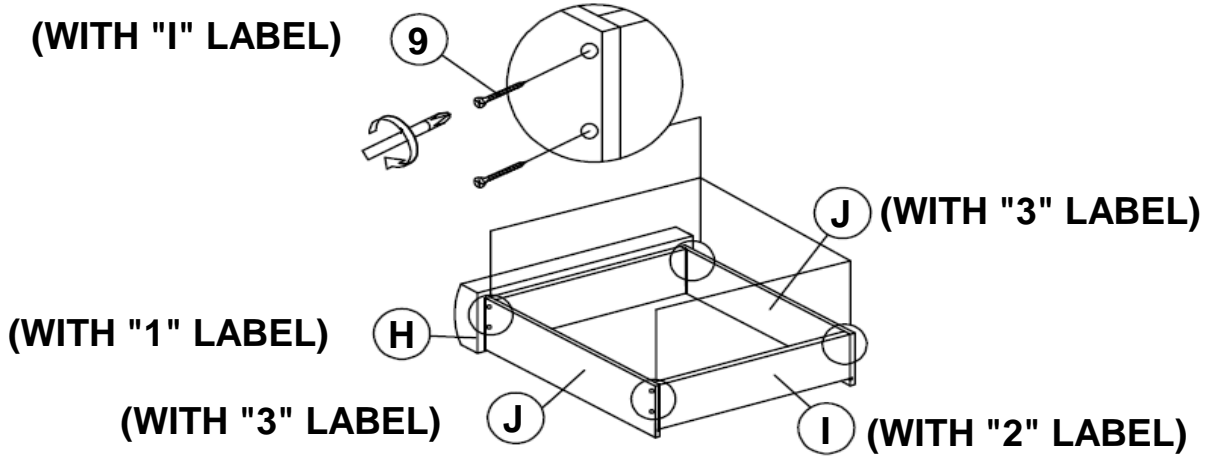

STEP 2

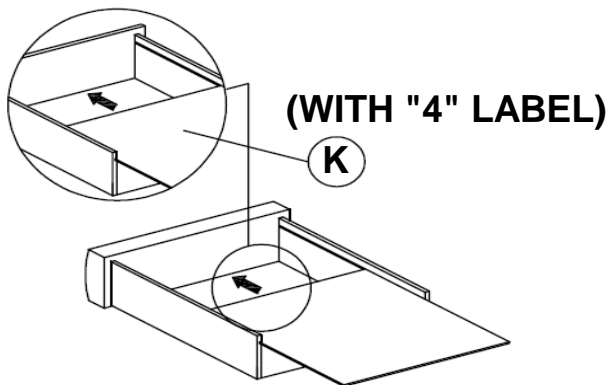

STEP 3

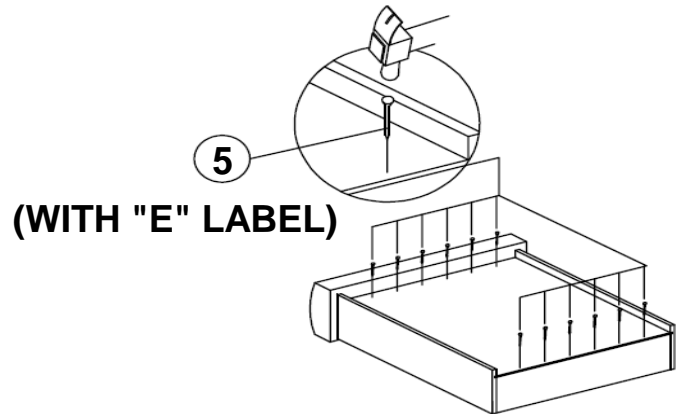

STEP 4

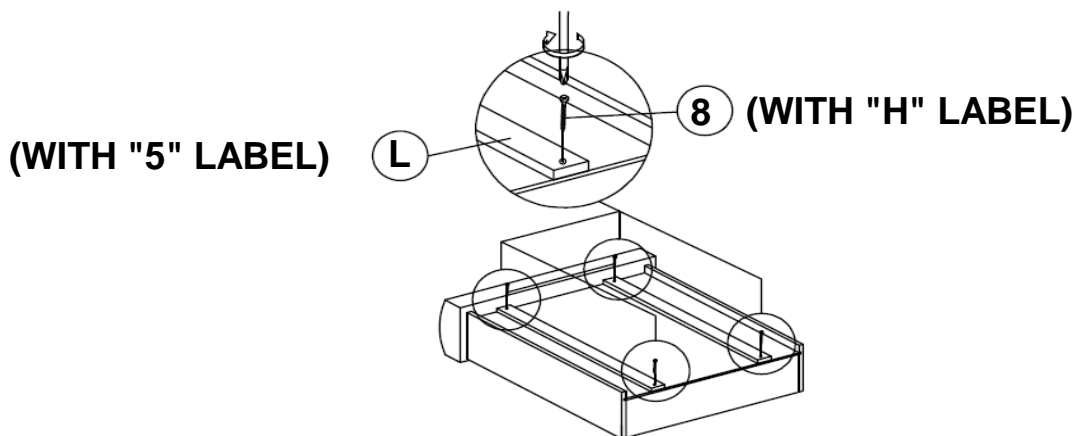

ASSEMBLY INSTRUCTIONS

STEP 5

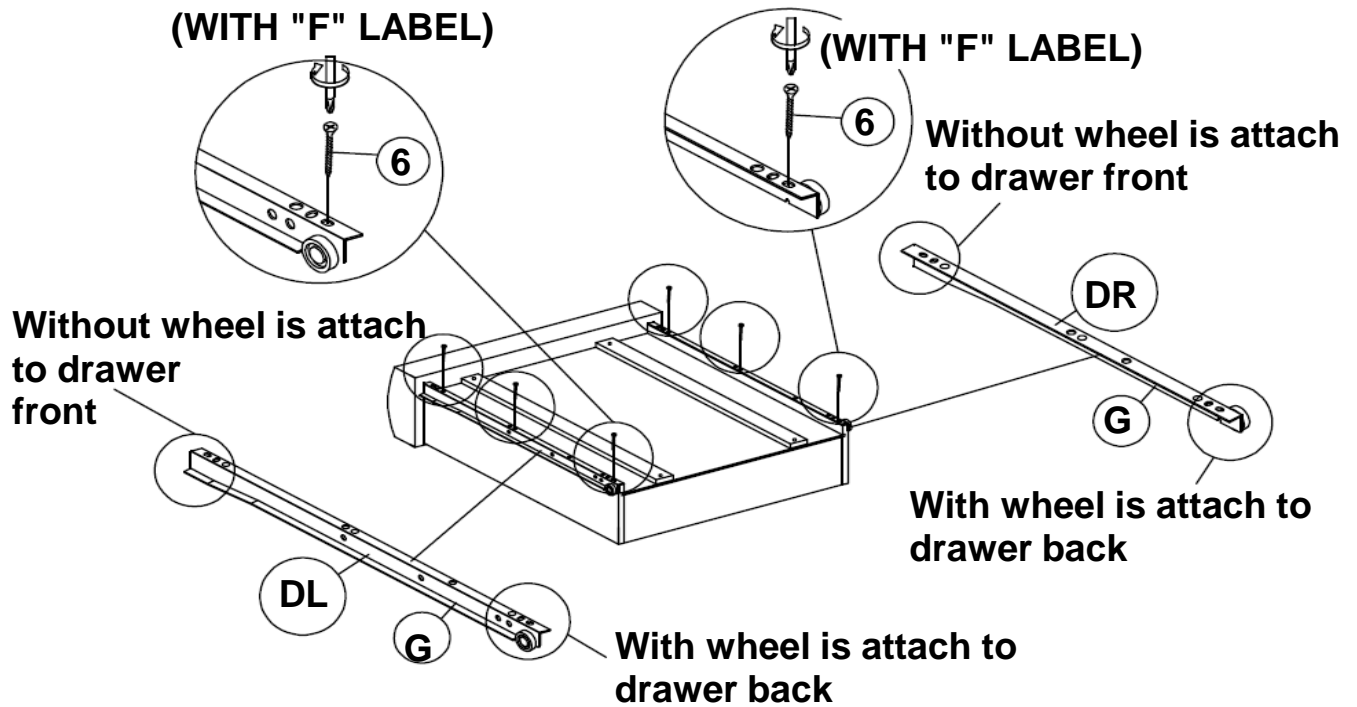

STEP 6

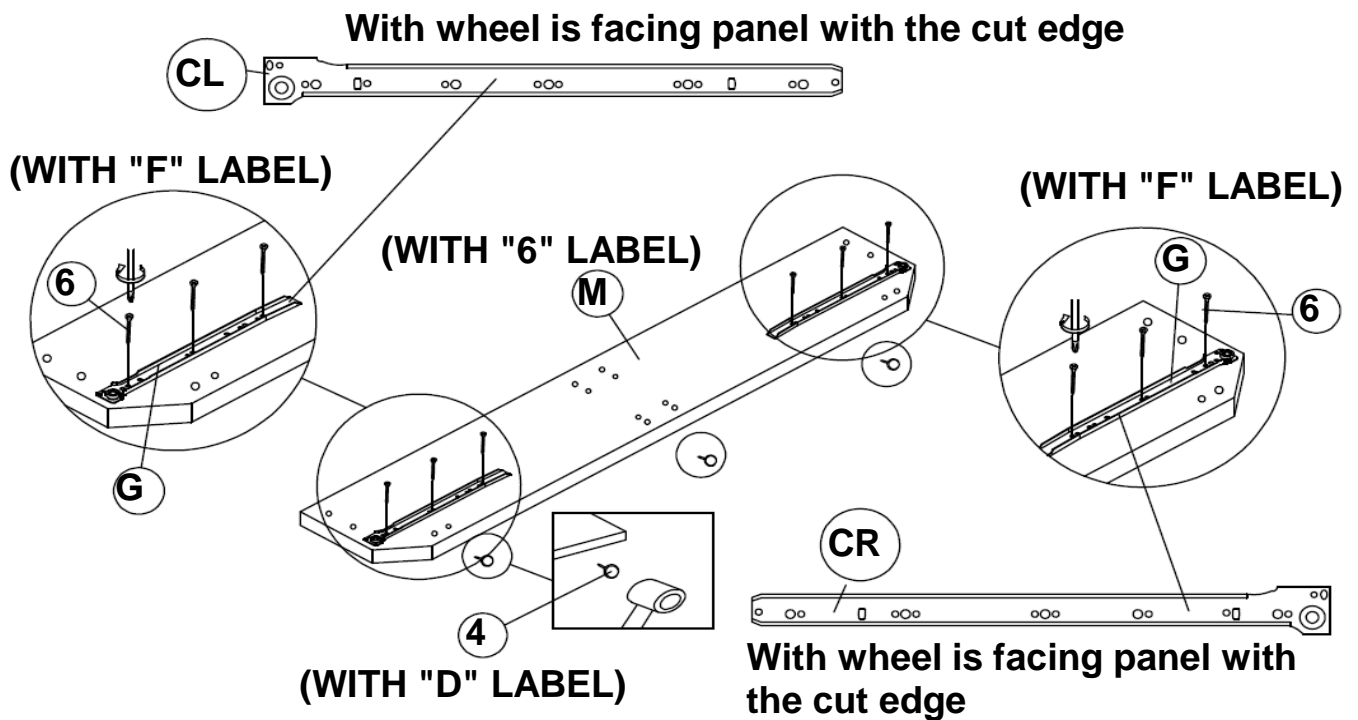

ASSEMBLY INSTRUCTIONS
STEP 7

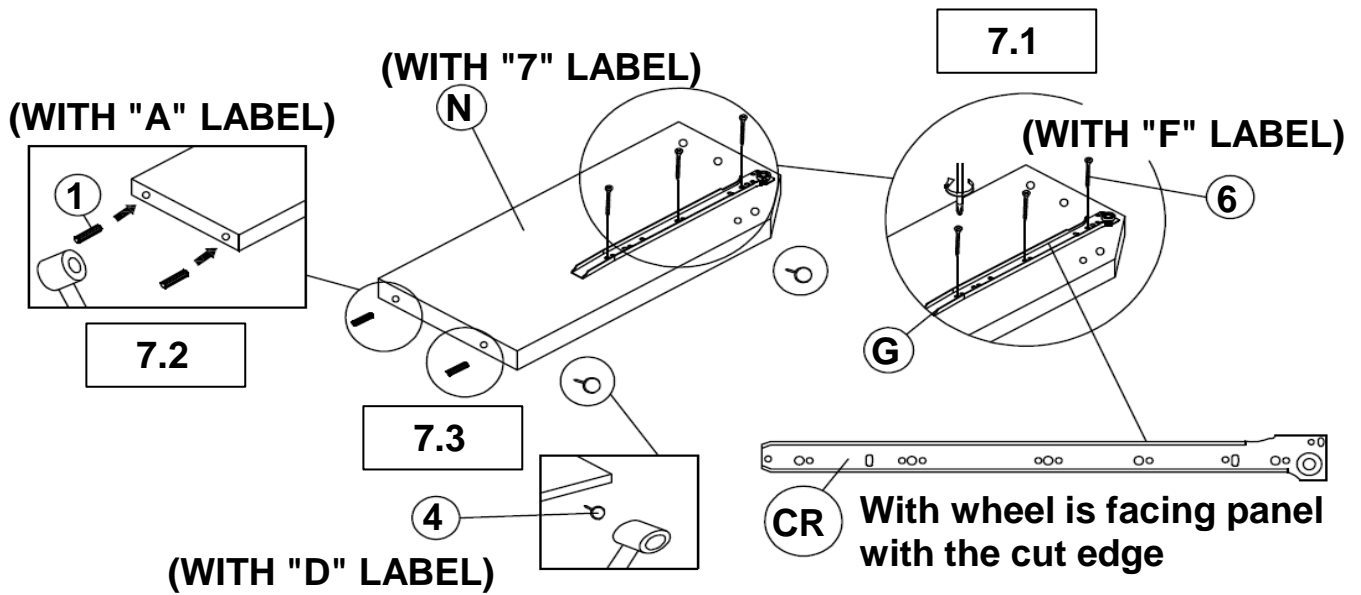

STEP 8

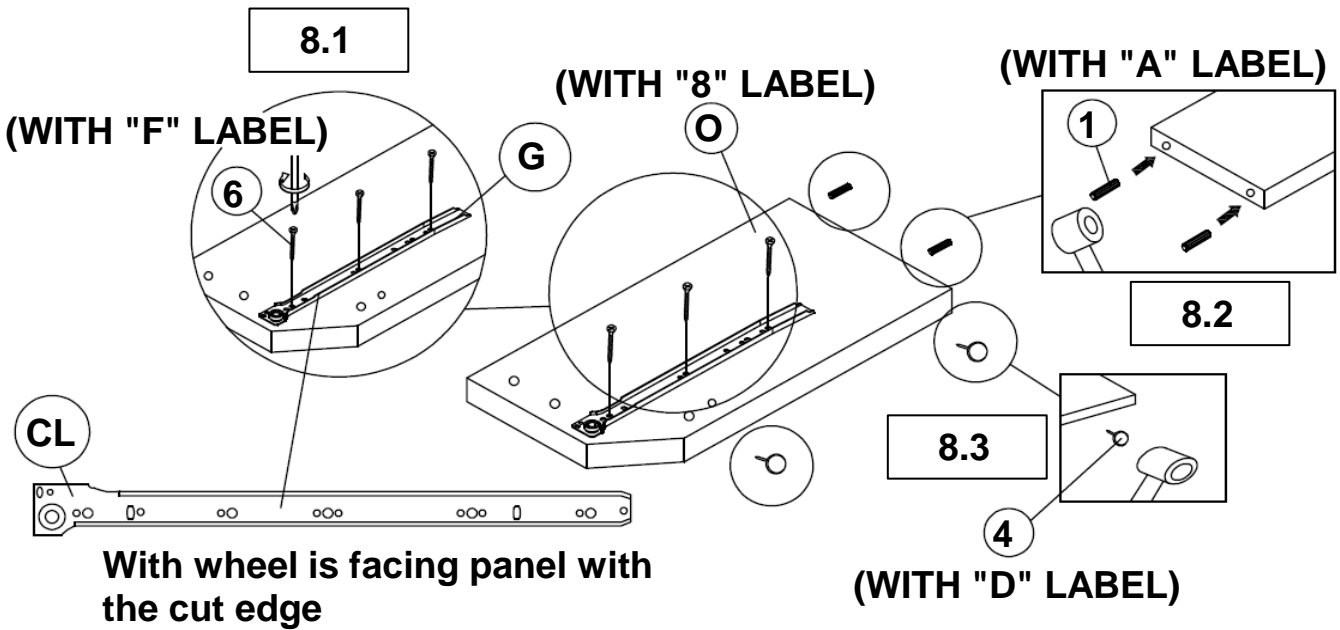

ASSEMBLY INSTRUCTIONS
STEP 12

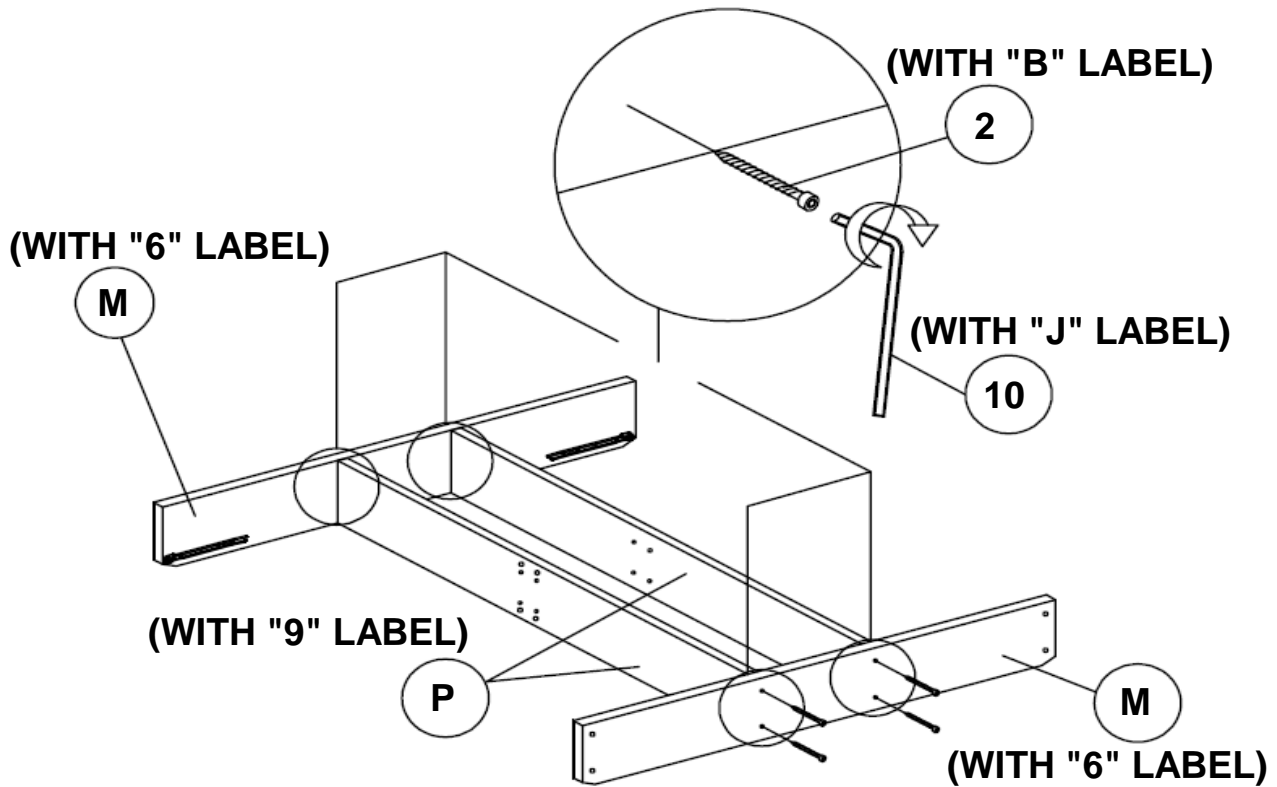

STEP 13

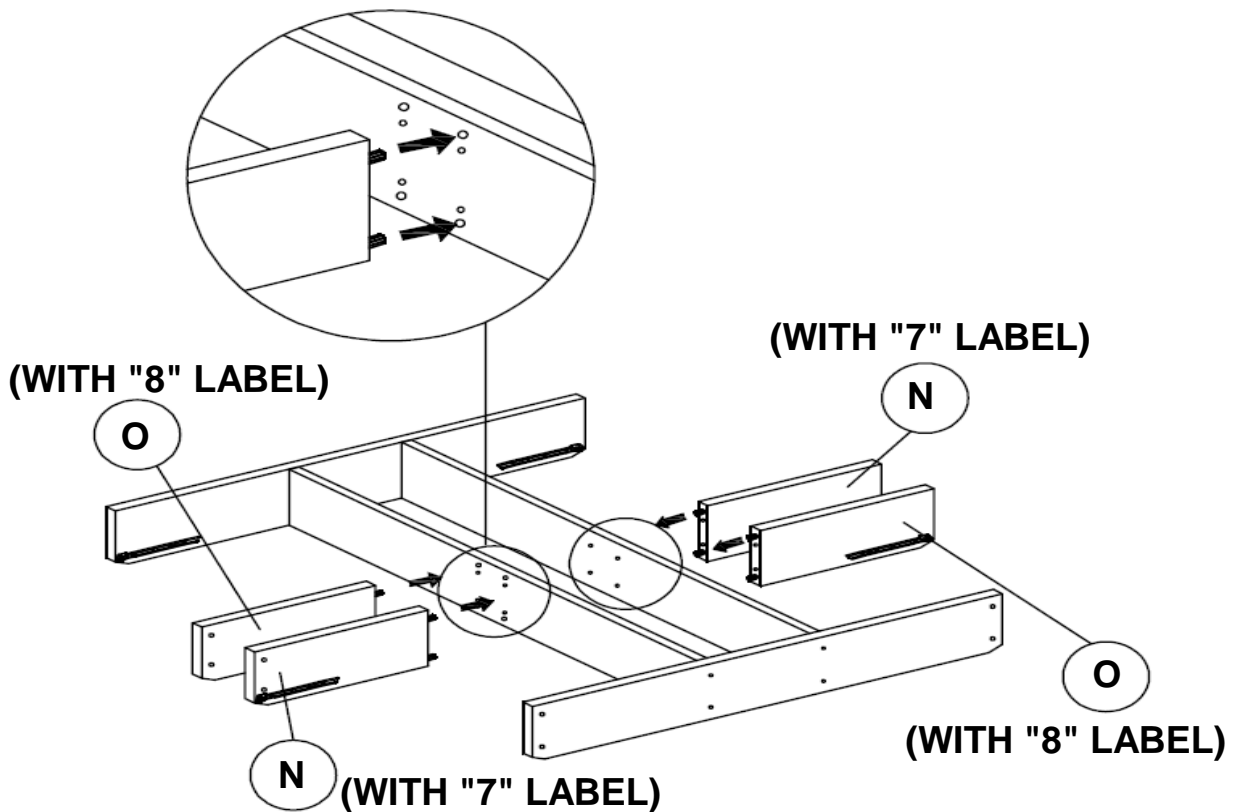

ASSEMBLY INSTRUCTIONS
STEP 14

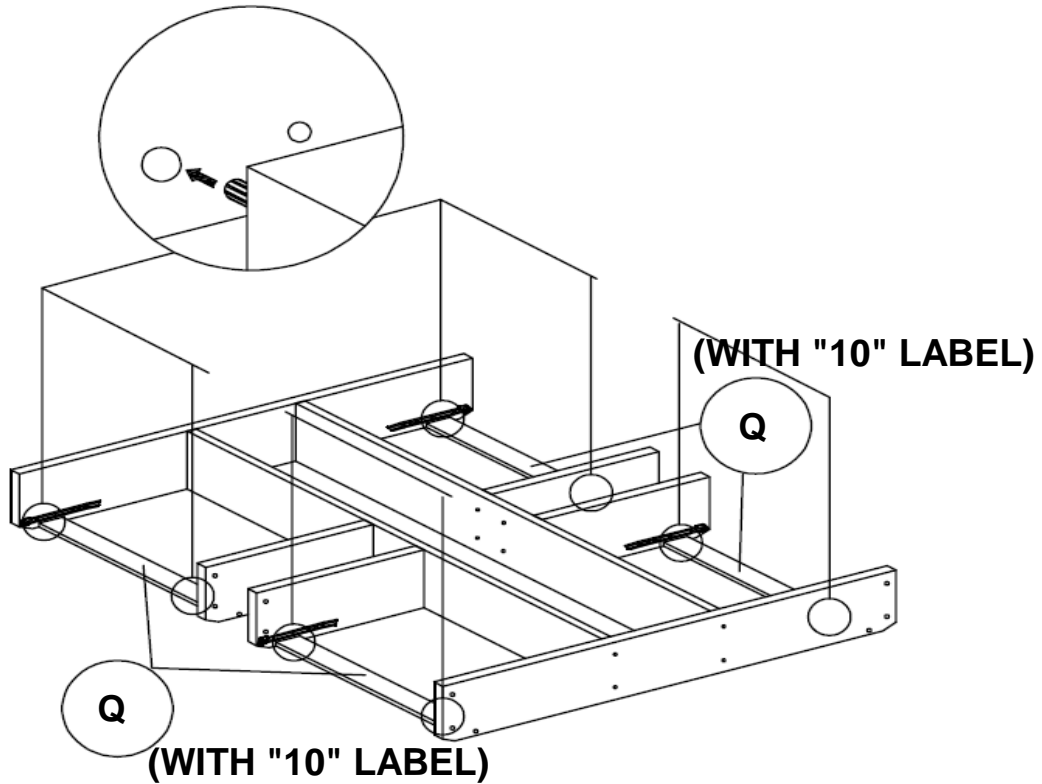

STEP 15

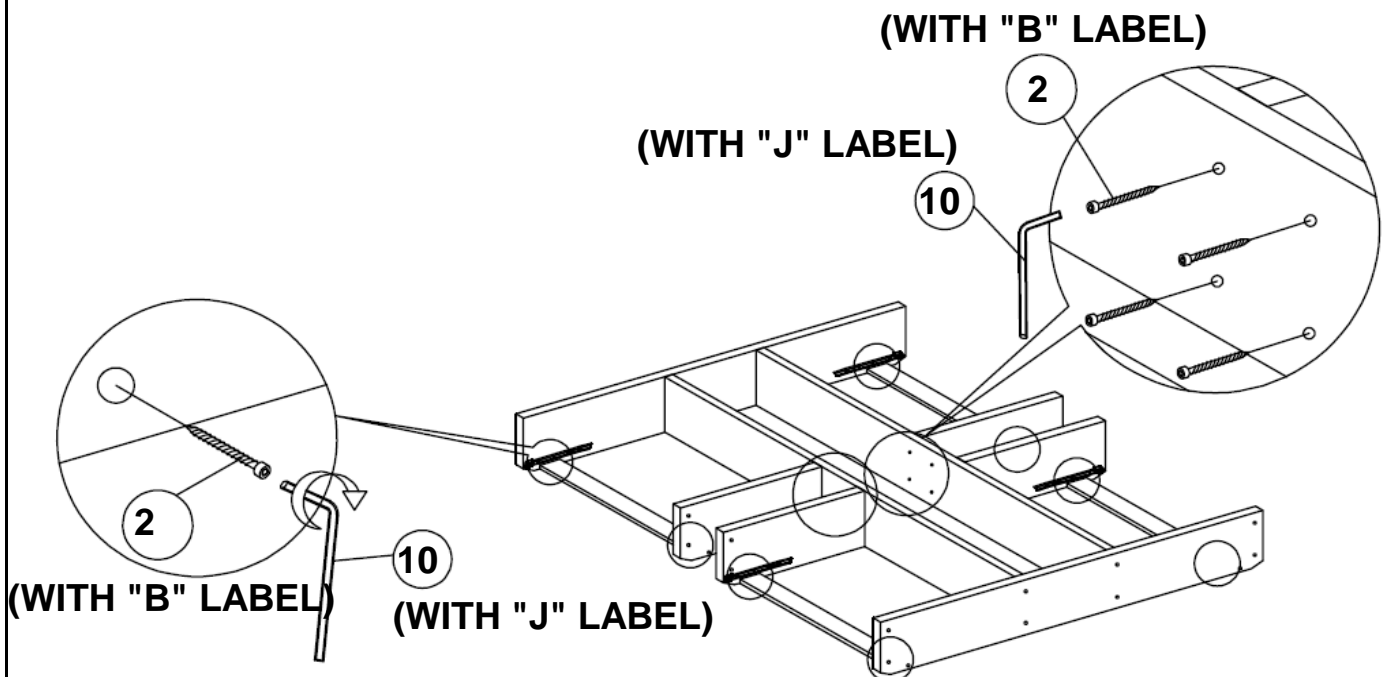

ASSEMBLY INSTRUCTIONS

STEP 16

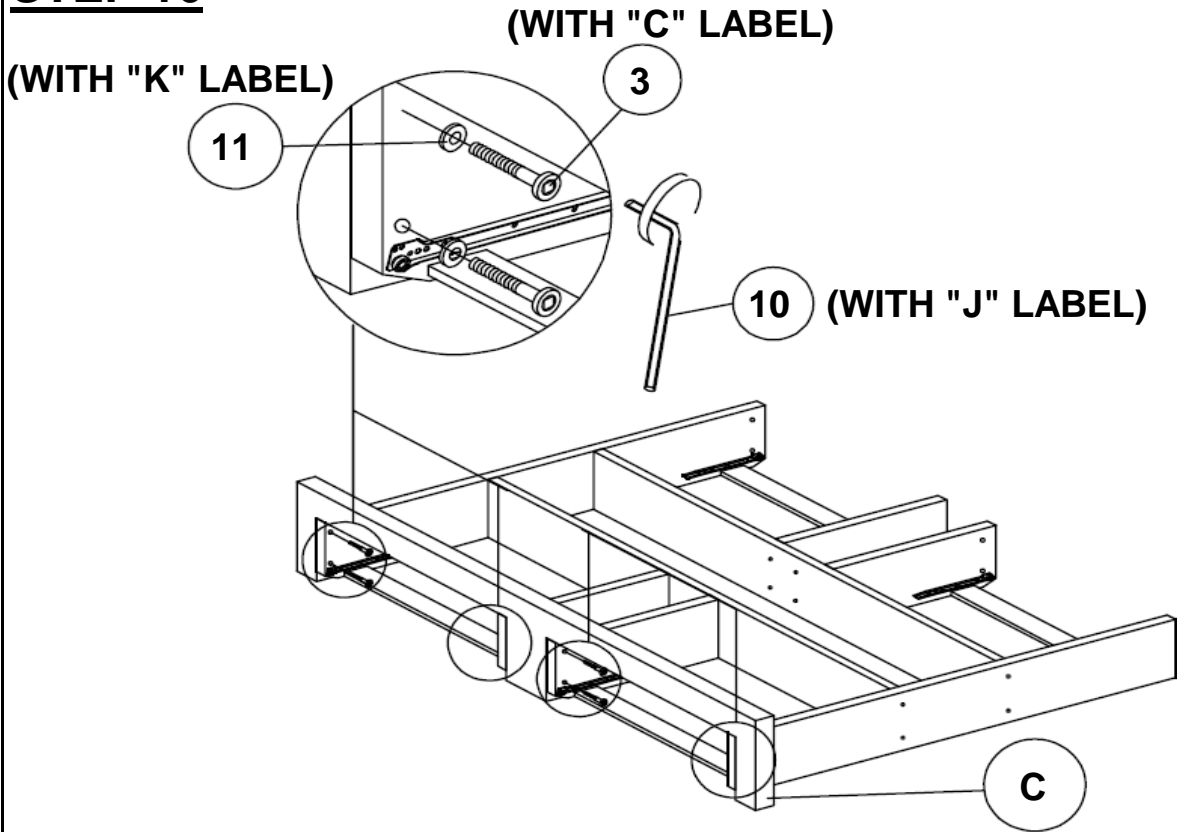

STEP 17

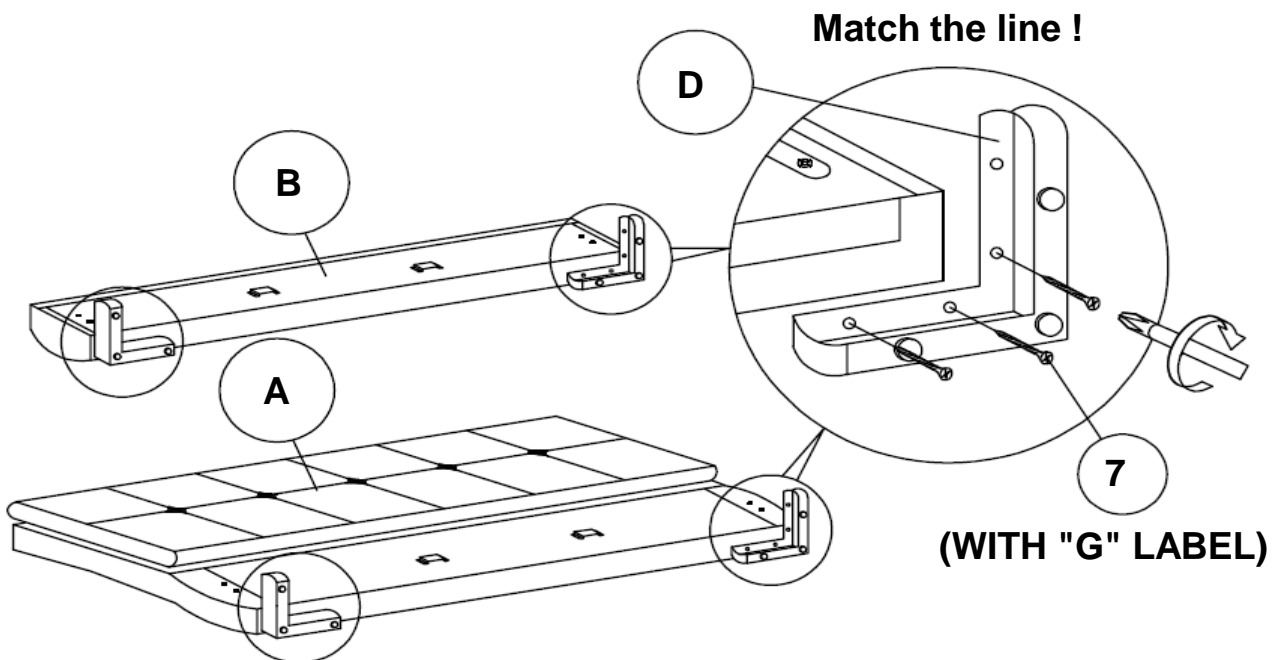

ASSEMBLY INSTRUCTIONS
STEP 18

Remove the bolt and flat washer from headboard panel and footboard panel (as shown)

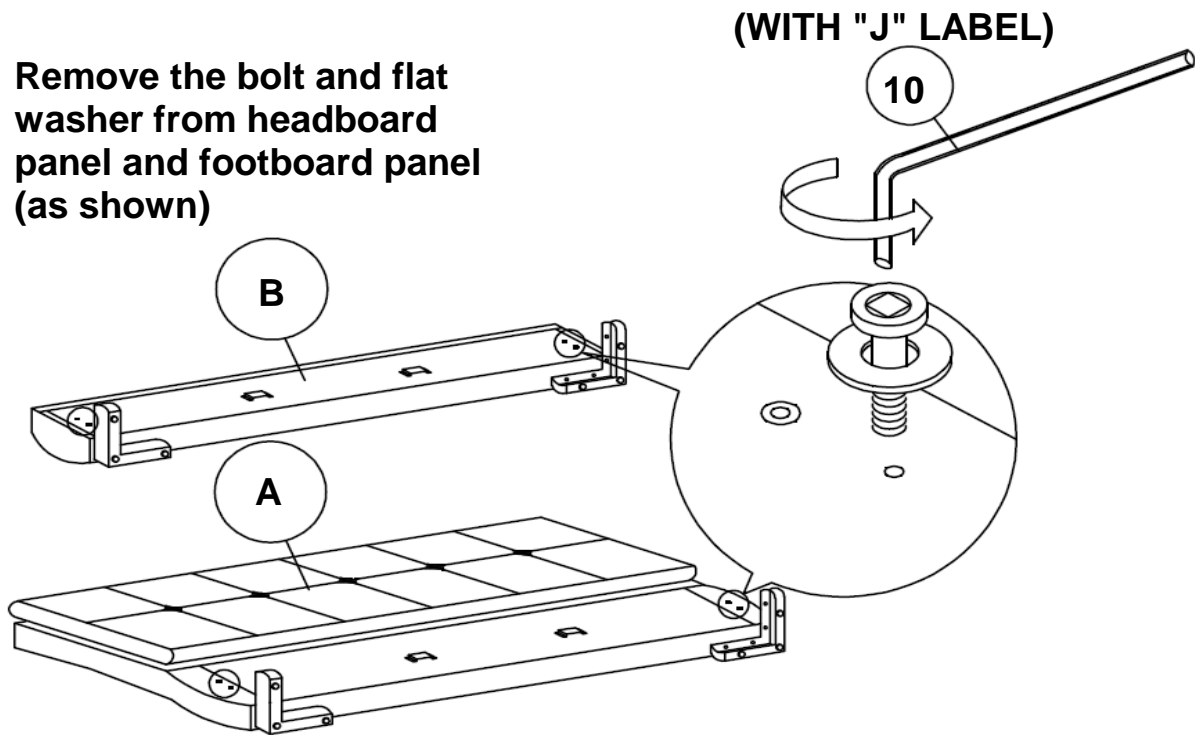

STEP 19

Align and fasten bolt and flat washer using allen wrench.

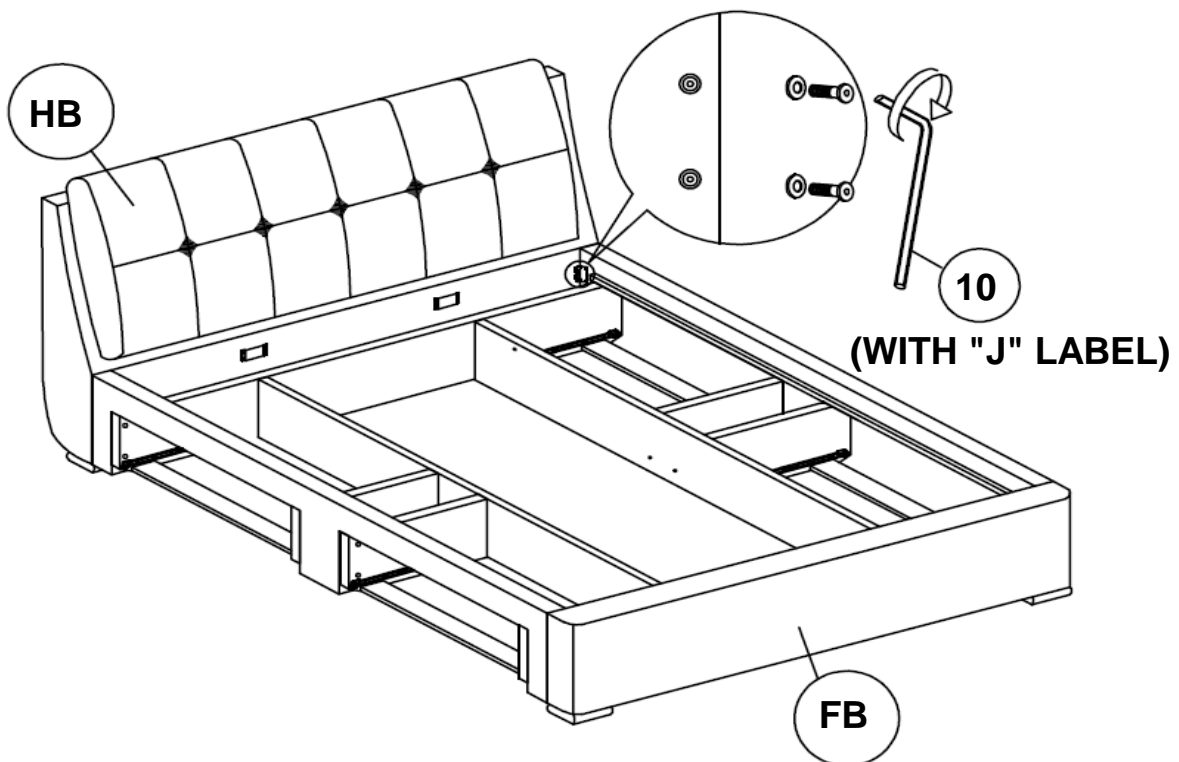

ITEM: **300523KW (B1-B5)**



ASSEMBLY INSTRUCTIONS
STEP 20

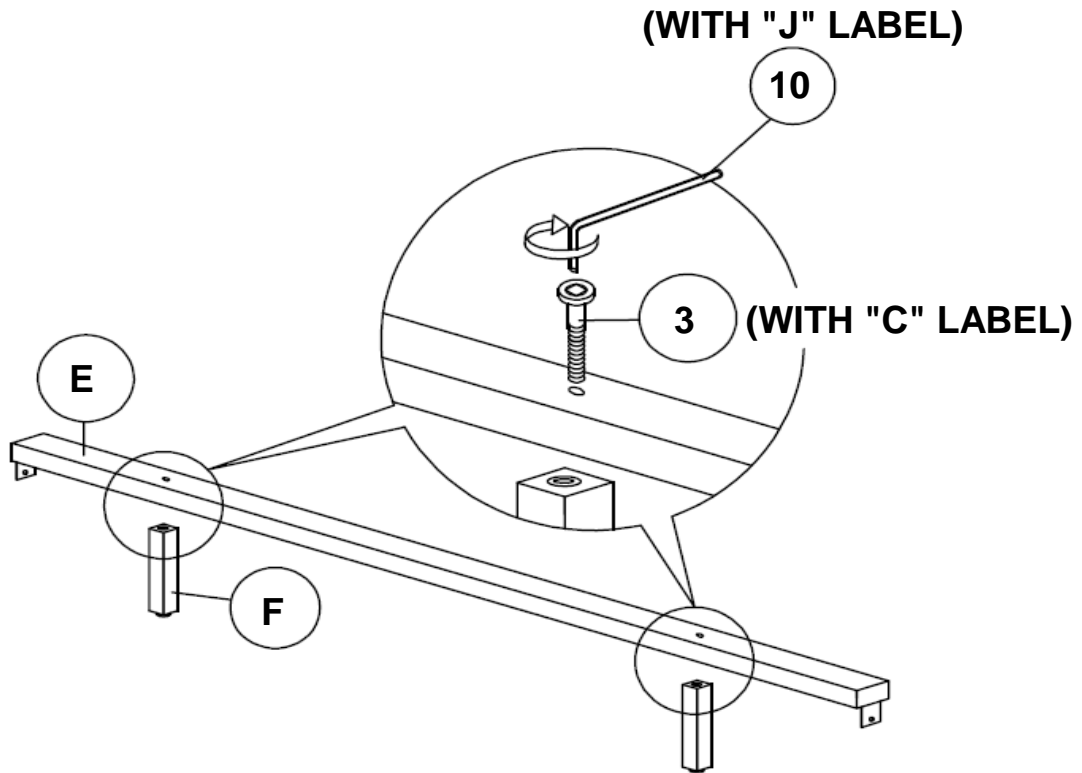

STEP 21

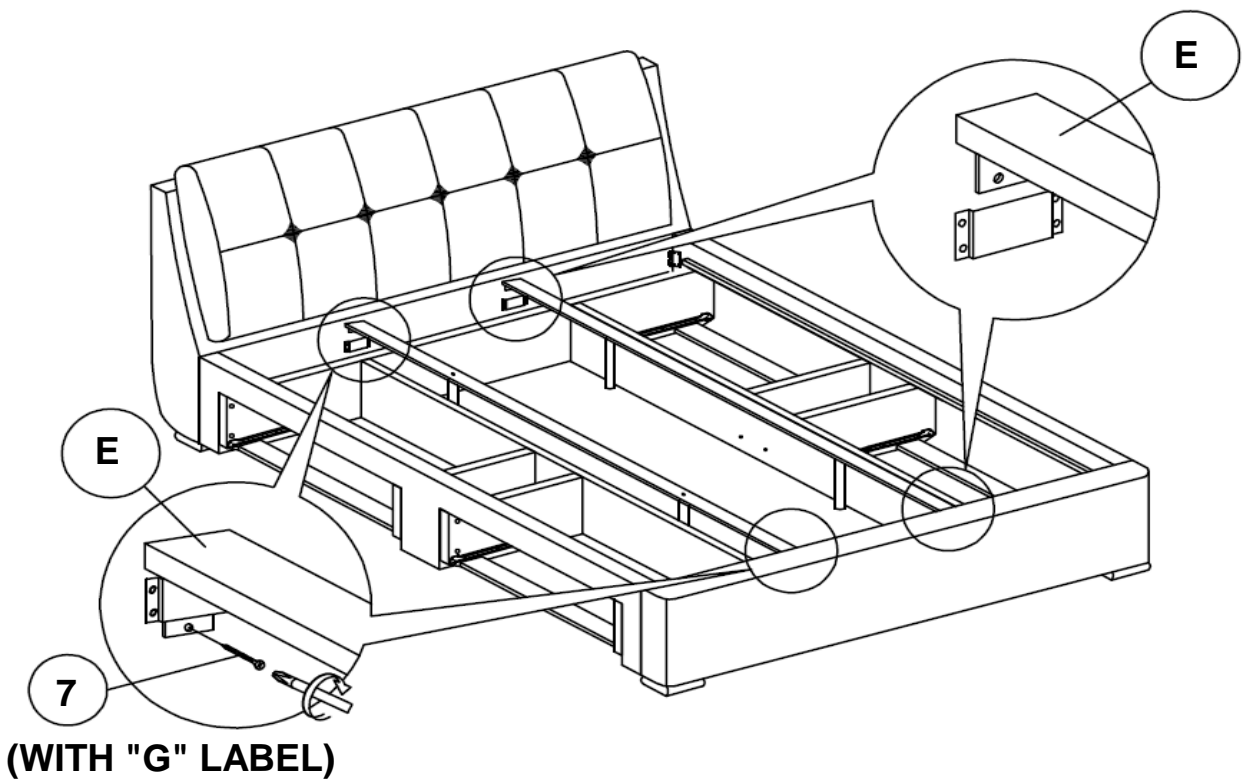

ITEM: **300523KW (B1-B5)**



ASSEMBLY INSTRUCTIONS

STEP 22

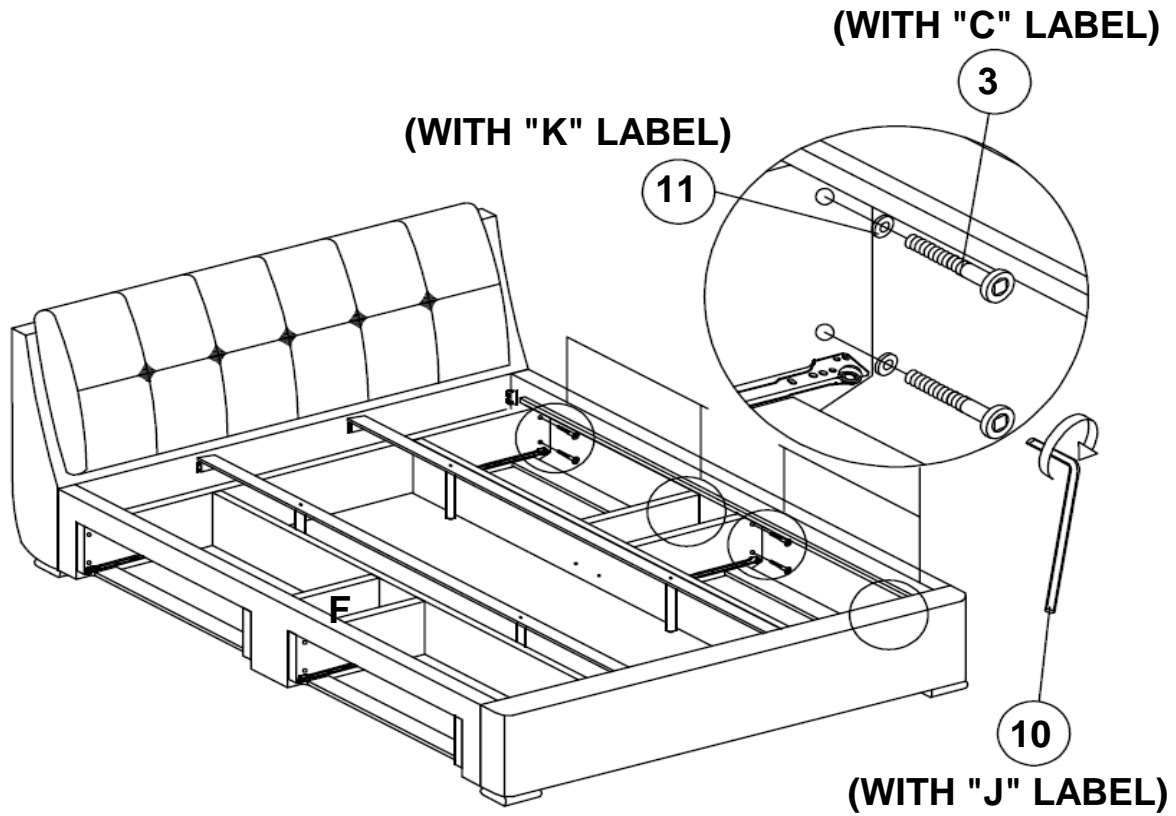

STEP 23

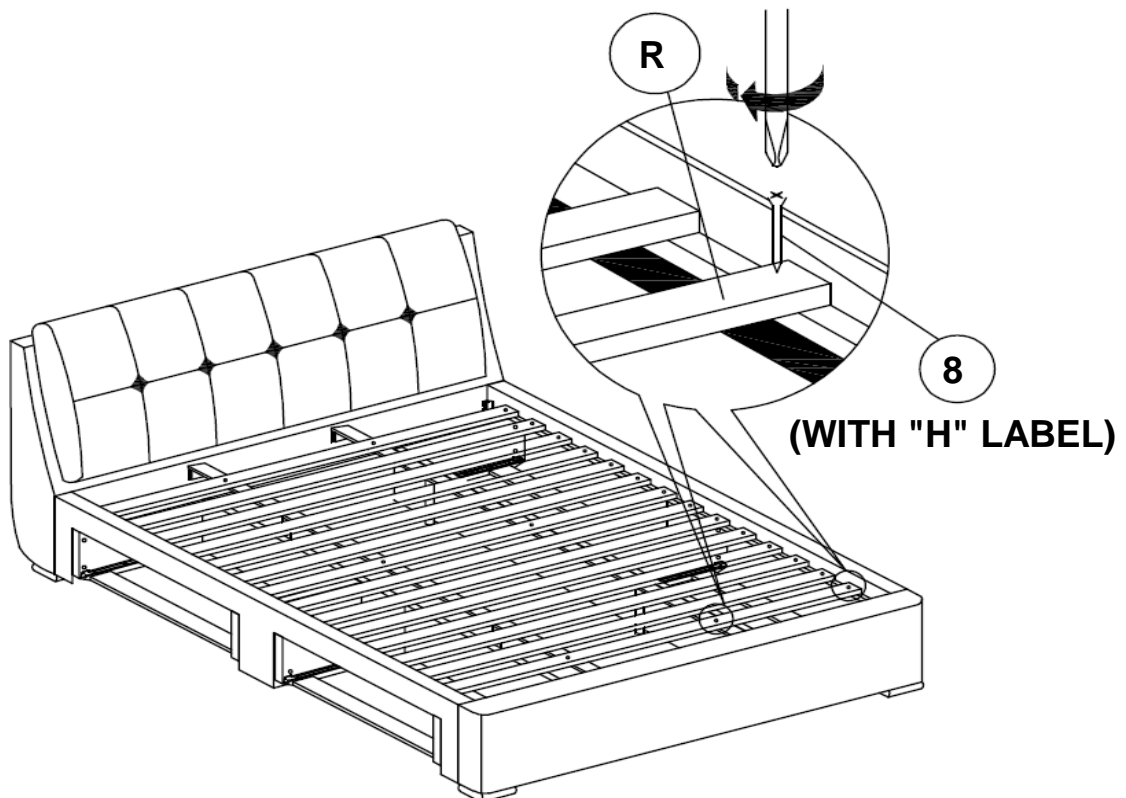

ITEM: **300523KW (B1-B5)**



ASSEMBLY INSTRUCTIONS

STEP 24

Fully tighten the bolt from STEP 19 with Allen wrench

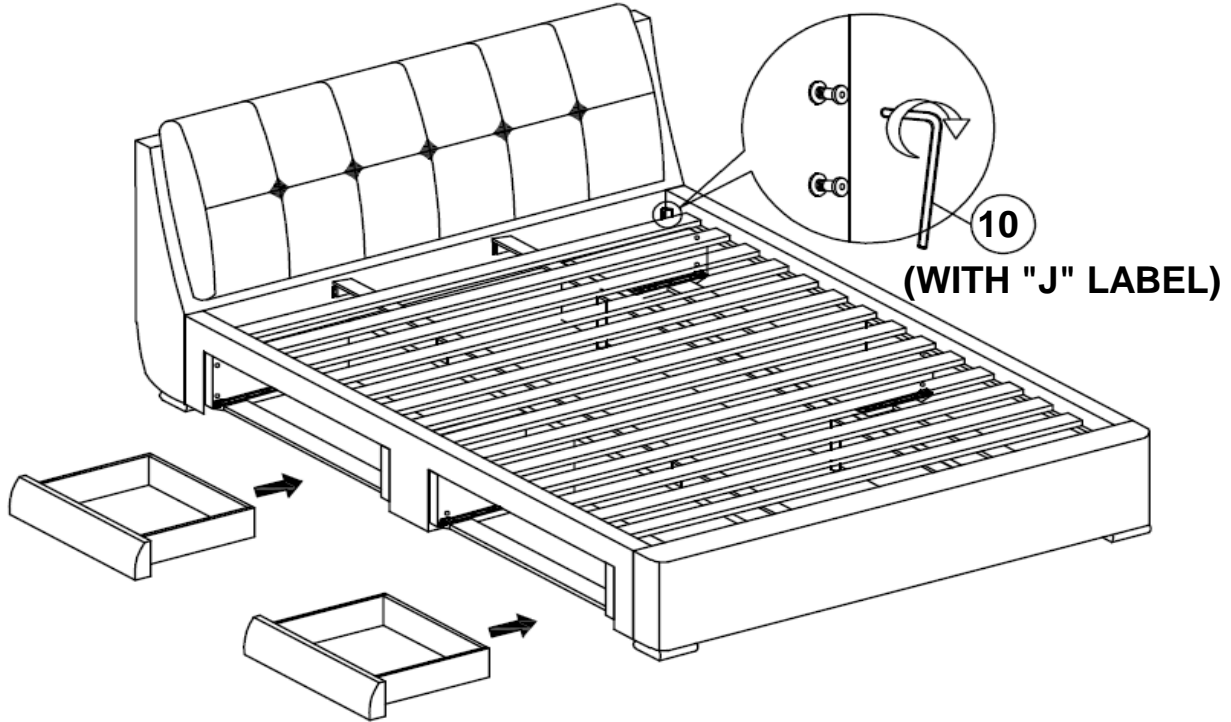

STEP 25

COMPLETE

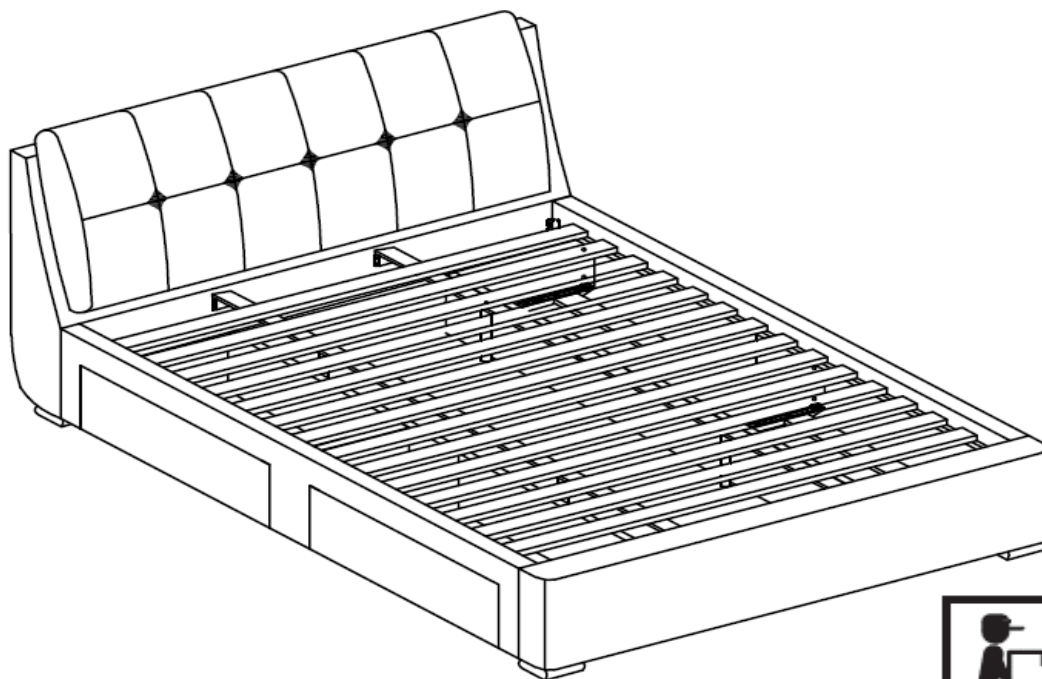

ITEM: **300523KW (B1-B5)**



Inner Size : 72.50"W X 85.25"D

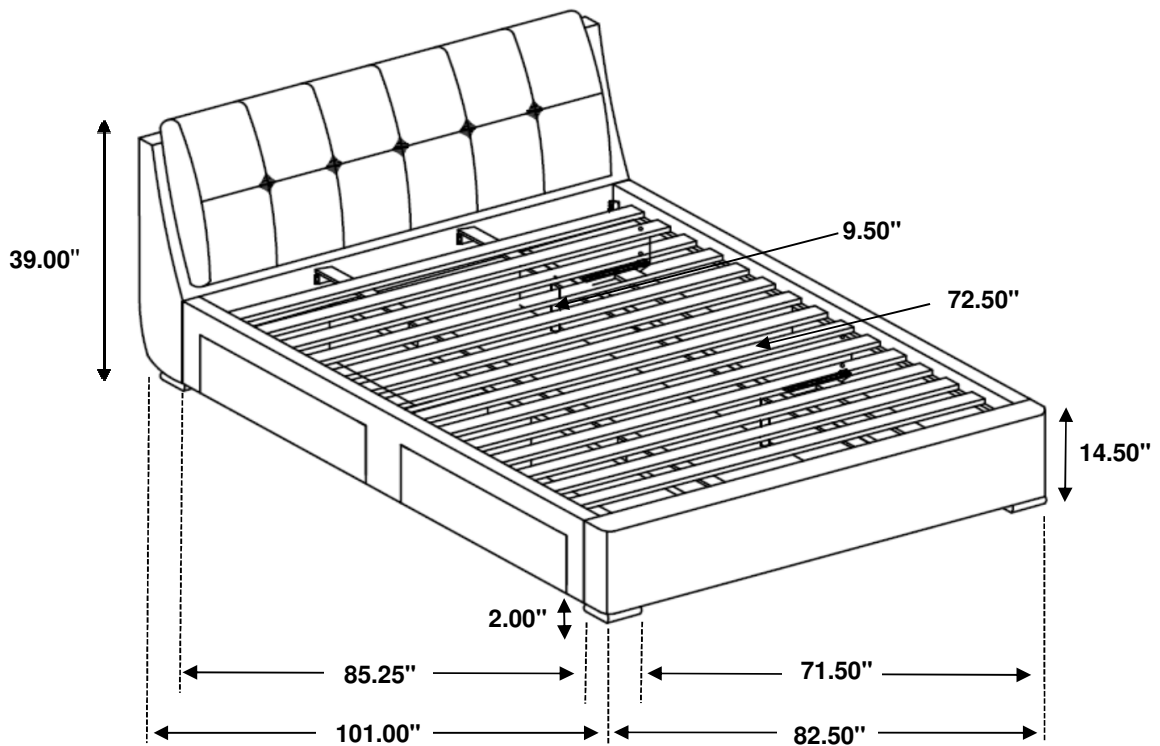

Note : Dimension tolerance $\pm 5\%$