

ASSEMBLY INSTRUCTIONS
COASTER FINE FURNITURE



Fine Furniture for every stage of life

223031KE (B1-B3)
Eastern King Bed

ITEM: 223031KE (B1-B3)

ASSEMBLY INSTRUCTIONS

ASSEMBLY TIPS:

1. Remove hardware from box and sort by size.
2. Please check to see that all hardware and parts are present prior to start of assembly.
3. Please follow attached instruction in the same sequence as numbered to assure fast and easy assembly.



WARNING !

1. Don't attempt to repair or modify parts that are broken or defective. Please contact the store immediately.
2. This product is for home use only and not intended for commercial establishment.





ASSEMBLY TIME

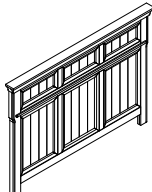

25 MINUTES

PARTS IDENTIFICATION

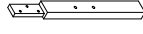

B1 (BOX 1)

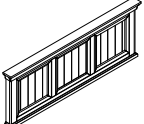
A	HEADBOARD PANEL		1 PC	C	RIGHT HEADBOARD LEG		1 PC
B	HEADBOARD BOTTOM RAIL		1 PC	D	LEFT HEADBOARD LEG		1 PC

B2 (BOX 2)

E	FOOTBOARD PANEL		1 PC	F	FOOTBOARD LEG		2 PCS
---	-----------------	---	------	---	---------------	---	-------

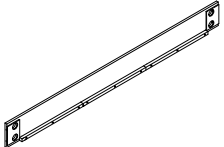
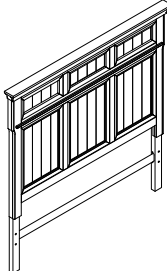
B3 (BOX 3)

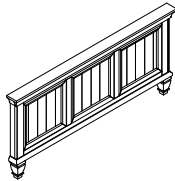
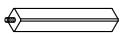
G	BED RAIL		2 PCS	HB	223031KE (B1) *FROM BOX 1 HEADBOARD		1 PC
H	BED SLAT		4 PCS	FB	223031KE (B2) *FROM BOX 2 FOOTBOARD		1 PC
I	BED SLAT SUPPORT WITH LEVELER		8 PCS				

ITEM: 223031KE (B1-B3)

ASSEMBLY INSTRUCTIONS

ASSEMBLY TIPS:

1. Remove hardware from box and sort by size.
2. Please check to see that all hardware and parts are present prior to start of assembly.
3. Please follow attached instruction in the same sequence as numbered to assure fast and easy assembly.







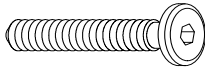
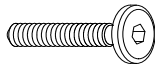

WARNING !

1. Don't attempt to repair or modify parts that are broken or defective. Please contact the store immediately.
2. This product is for home use only and not intended for commercial establishment.

HARDWARE IDENTIFICATION





Z-B1 (BOX 1) - HARDWARE PACK IS LOCATED IN 223031KE (B1)

1	BIG BOLT (M8 x 50mm - BLK)		6 PCS	5	SMALL BOLT (M6 x 40mm - BLK)		2 PCS
2	BIG LOCK WASHER (M8 - BLK)		6 PCS	6	SMALL LOCK WASHER (M6 - BLK)		2 PCS
3	BIG FLAT WASHER (M8 - BLK)		6 PCS	7	SMALL FLAT WASHER (M6 - BLK)		2 PCS
4	BIG ALLEN WRENCH (M5 - BLK)		1 PC	8	SMALL ALLEN WRENCH (M4 - BLK)		1 PC

Z-B2 (BOX 2) - HARDWARE PACK IS LOCATED IN 223031KE (B2)

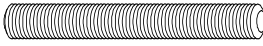
9	THREADED BOLT (M10 x 70mm - SR)		2 PCS
---	---	---	-------

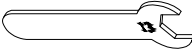
Z-B3 (BOX 3) - HARDWARE PACK IS LOCATED IN 223031KE (B3)

10	THREADED BOLT (M8 x 100mm - RBW)		8 PCS
11	HEX NUT (M8 x 15mm - RBW)		8 PCS
12	WRENCH (M13 - SR)		1 PC
13	PAN HEAD SCREW (4 x 32mm - SR)		8 PCS

NOTE:

Phillips head screw driver is required in the assembly process; however, manufacturer does not provide this item.

ITEM: 223031KE (B1-B3)

ASSEMBLY INSTRUCTIONS

223031KE (B1) - BOX 1

STEP 1

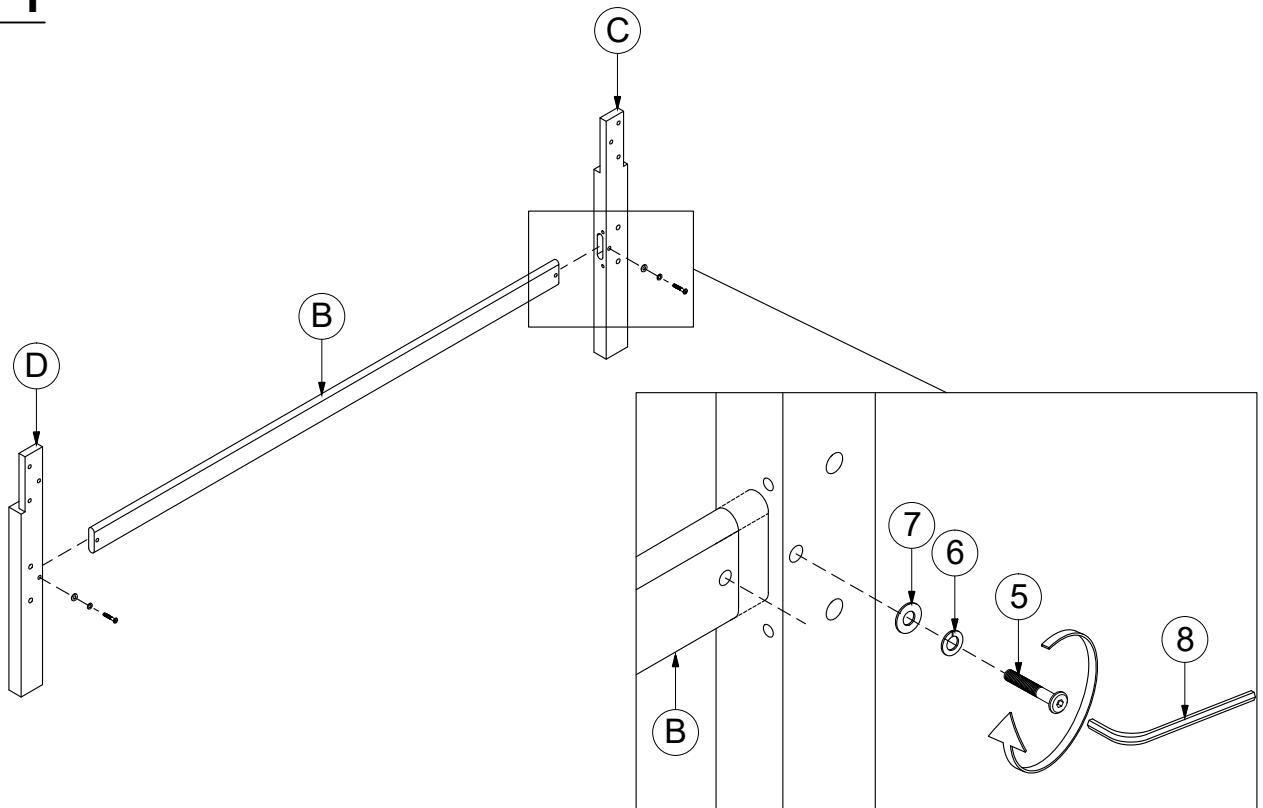

STEP 2

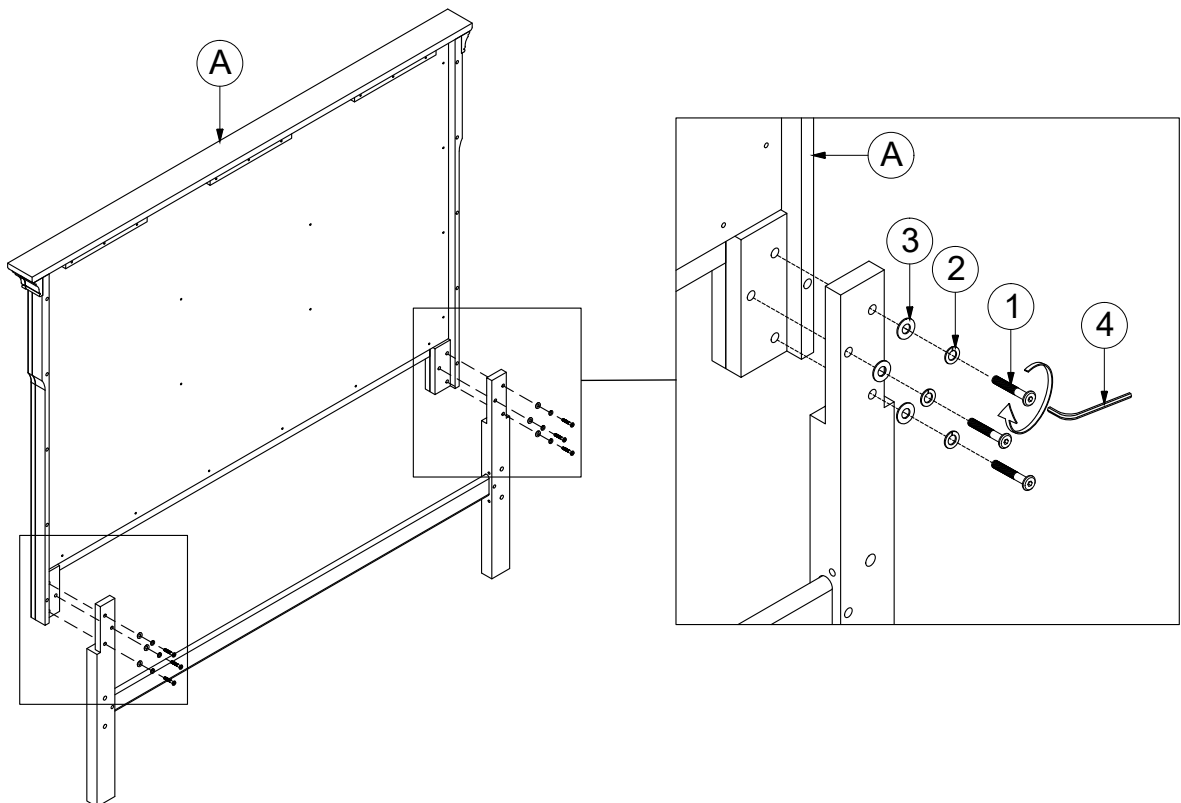

ITEM: 223031KE (B1-B3)

ASSEMBLY INSTRUCTIONS

223031KE (B2) - BOX 2

STEP 3

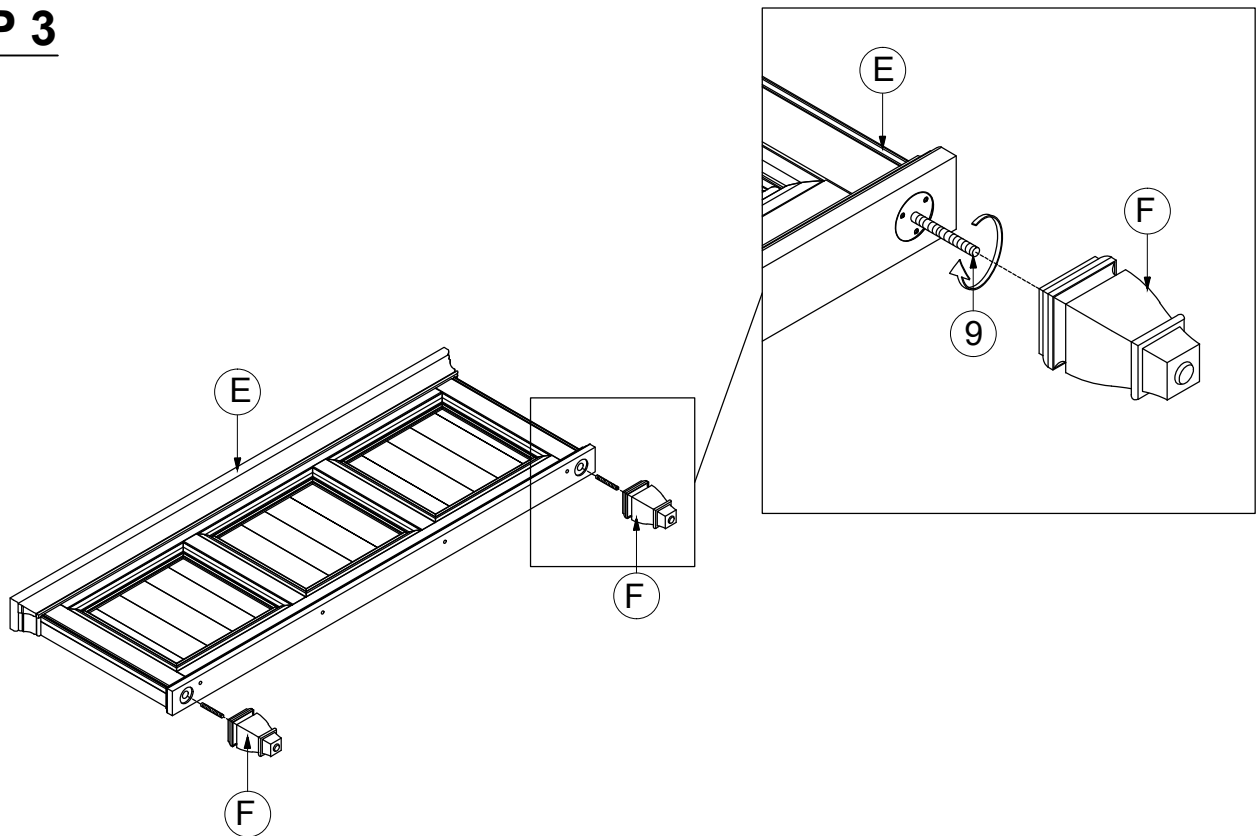

STEP 4

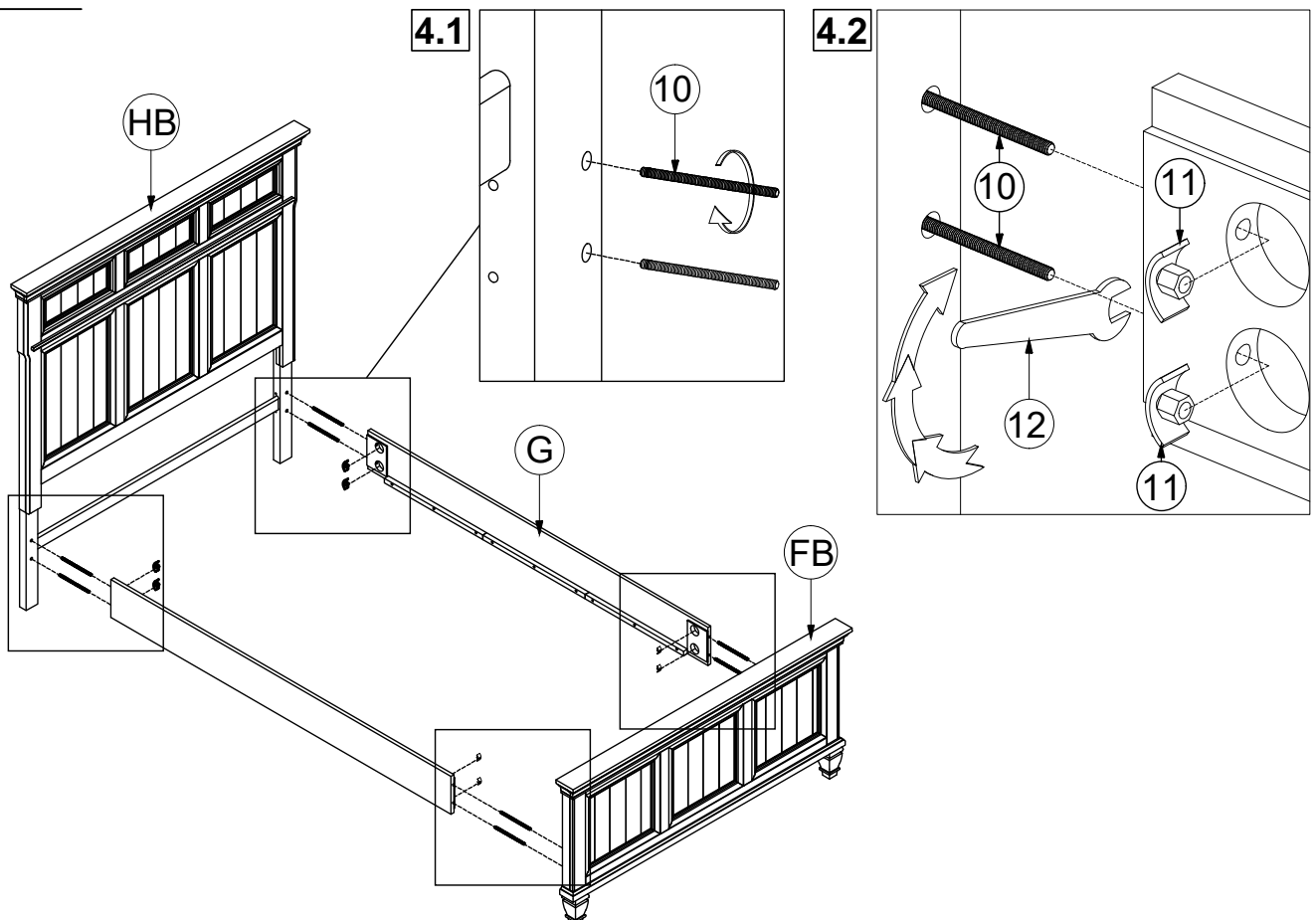

ITEM: 223031KE (B1-B3)

ASSEMBLY INSTRUCTIONS

STEP 5

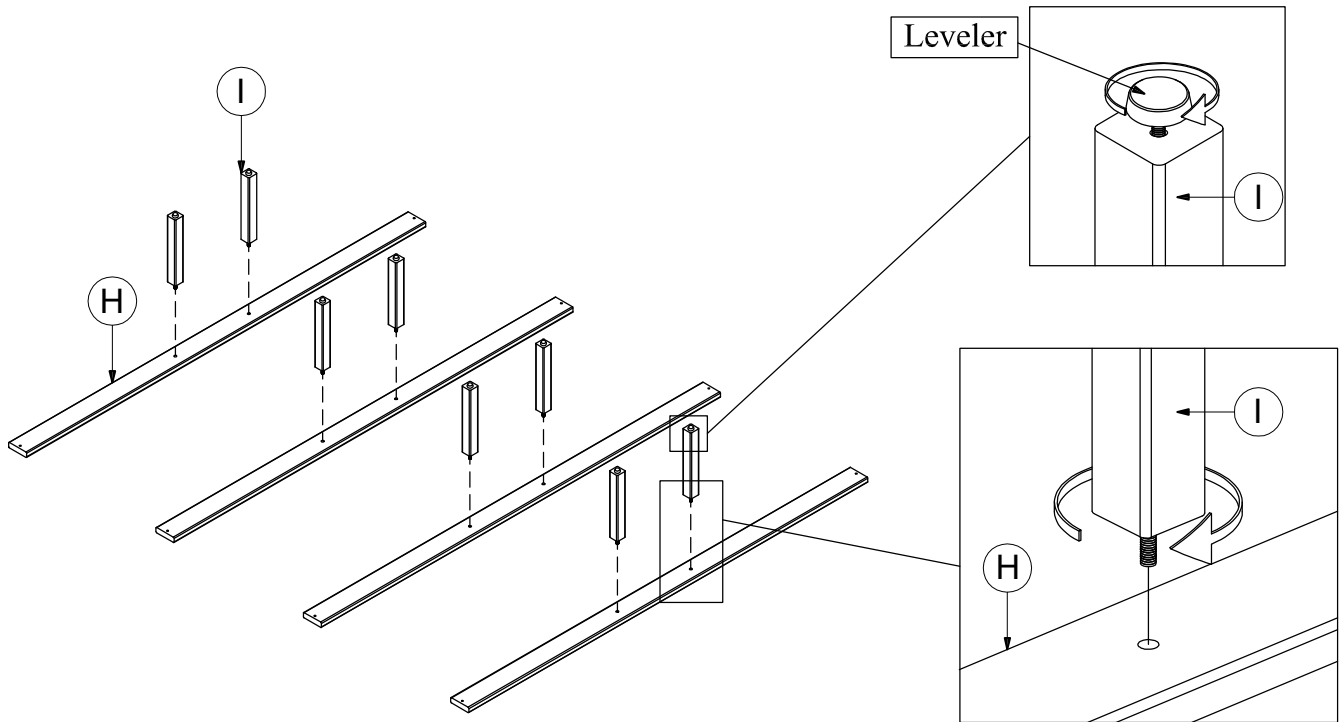

STEP 6

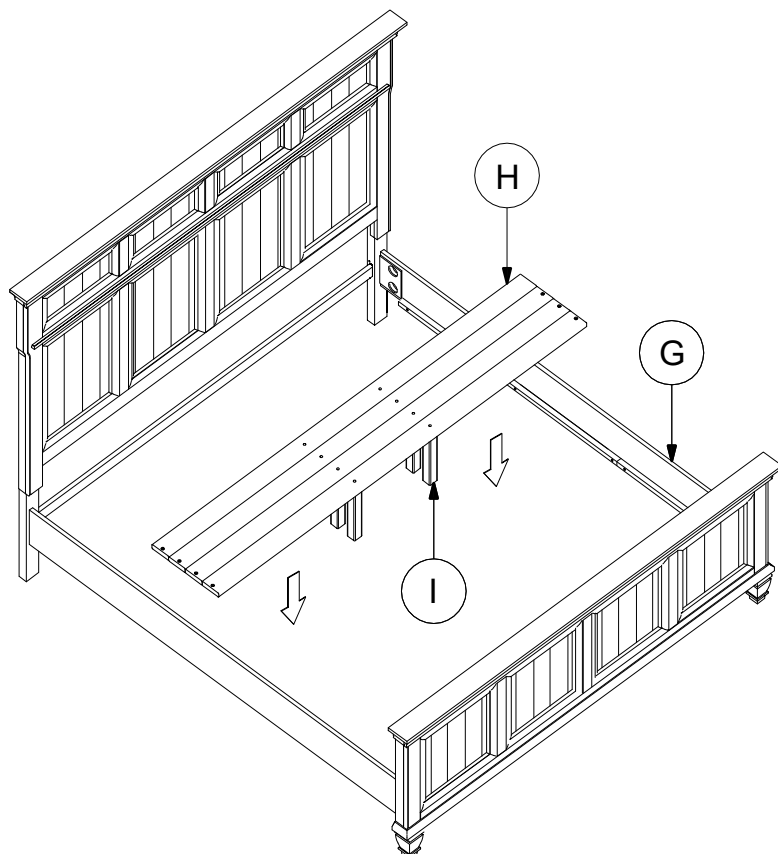

ITEM: 223031KE (B1-B3)

ASSEMBLY INSTRUCTIONS

STEP 7

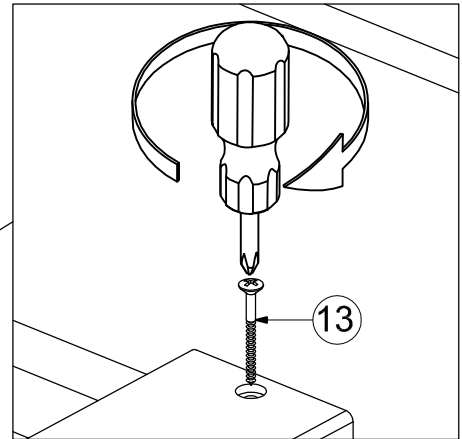
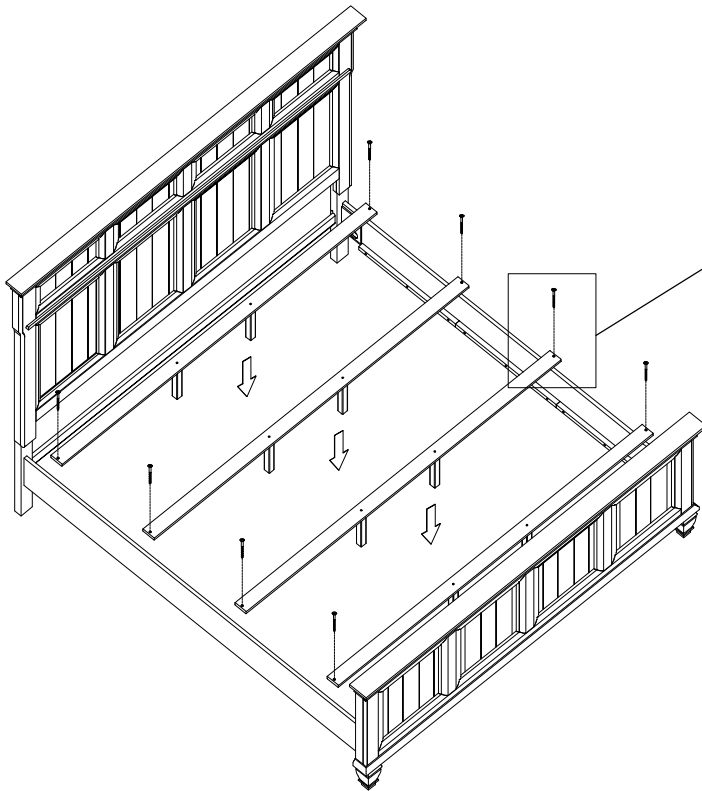

STEP 8

COMPLETE



ITEM: 223031KE (B1-B3)

INNER SIZE : 77" x 81"

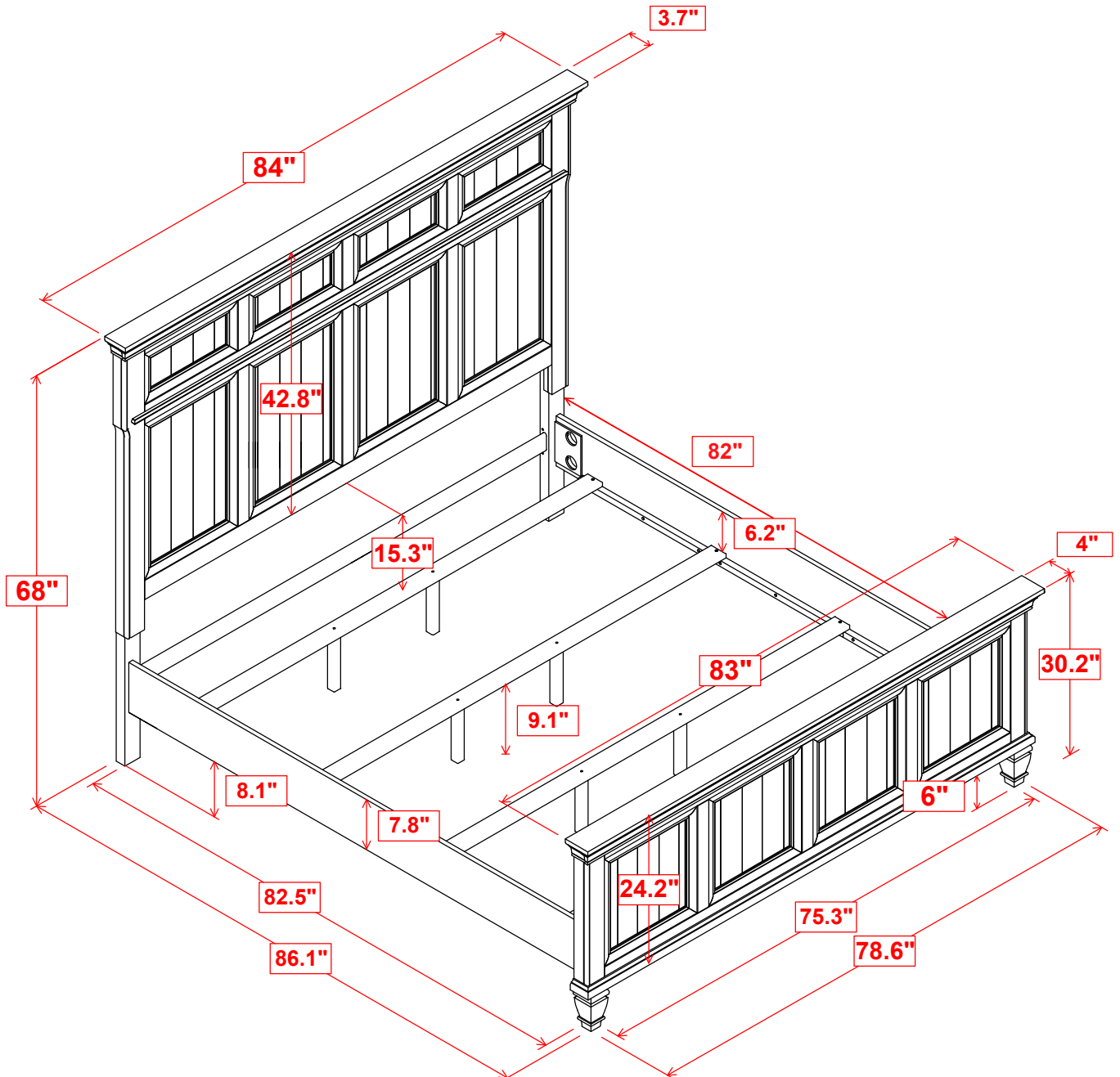

NOTE: Dimension tolerance $\pm 5\%$