

ITEM CODE : SH03-52-201
Assembly Instructions

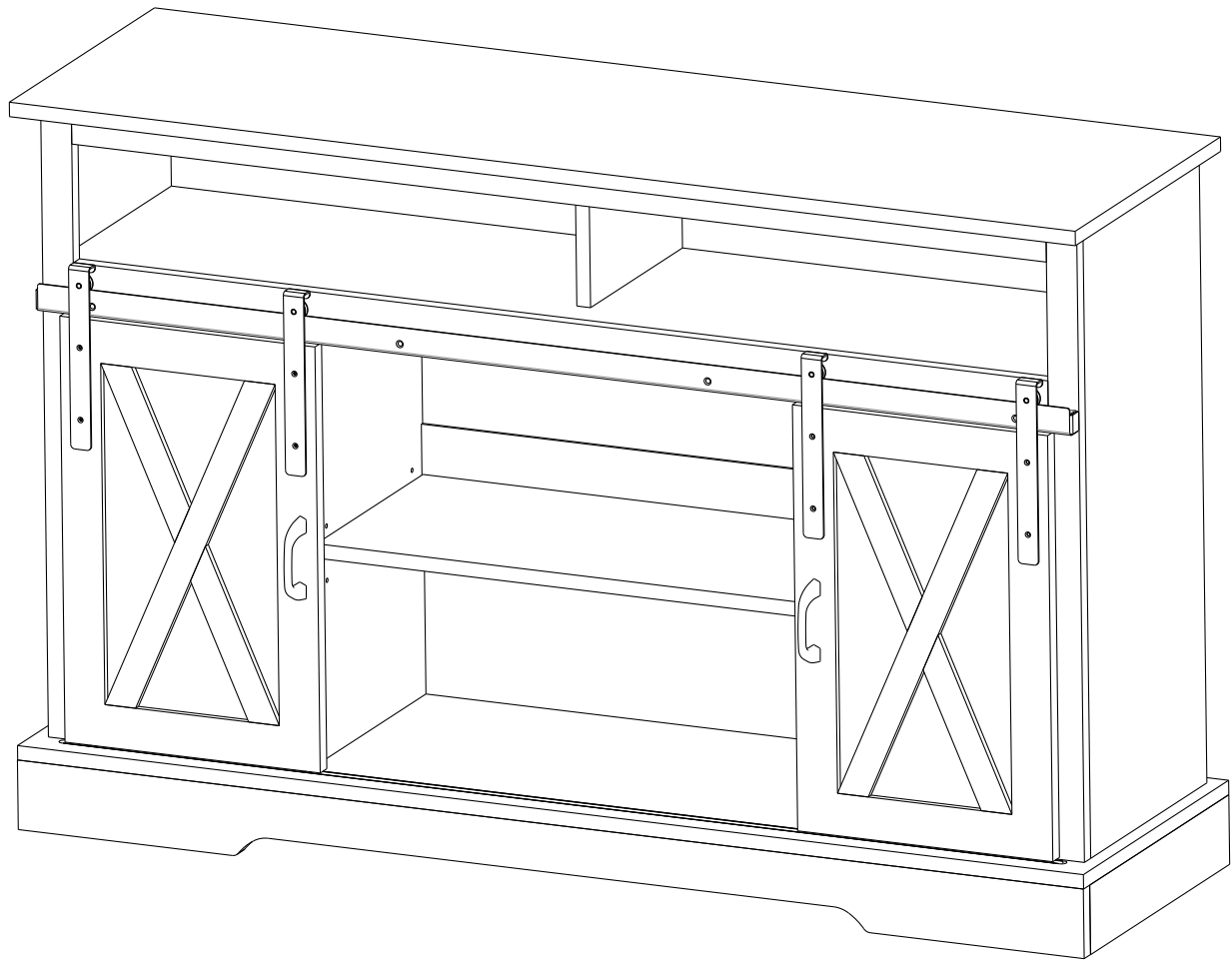



ATTENTION: Is your product damaged or missing assembly instructions?

DO NOT RETURN!!!PLEASE READ THE FOLLOWING!!!

For Replacement / Missing Parts: www.modarte.com/parts

For Assembly Instructions and Assembly Videos: <https://modarte.com/assembly/>

All other enquiries, please send email to: operations@modarte.com or 973-264-1228

IF YOU ARE MISSING PARTS, OR PARTS ARRIVED DAMAGED:

For fastest service, please contact us and we will mail you replacements parts the next business day. To request replacement parts, please fill out a parts request form on our website at www.modarte.com/parts, or email us at operations@modarte.com. DO NOT RETURN TO THE RETAILER.

CUSTOMER CARE

For any other customer service enquiries, please feel free to reach out to us:

operations@modarte.com or 973-264-1228

Thank You!

General Assembly Guidelines

- I. Ensure that all parts and hardware are available before beginning assembly.
- II. Follow each step carefully to ensure the proper assembly of this product.
- III. Two people are recommended for ease in the assembly of this product.
Approximate time : 30 Minutes
- IV. The three main types of hardware used to assemble this product are : wood dowels , screws and bolts.
- V. The provided glue is to secure wood dowels in place . When first inserting dowels , locate the appropriate hole for the dowel , place a small amount of glue in the hole and insert the dowel . Wipe away excess glue immediately.

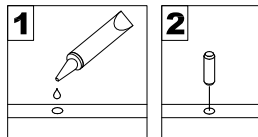

In future assembly steps when dowels are necessary to attach assembly parts together , place a small amount of glue on the end of the dowel before attaching parts together . Wipe away excess glue immediately.

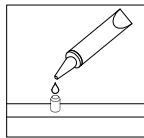

- VI. A Phillips head screwdriver is required for the assembly of this product .

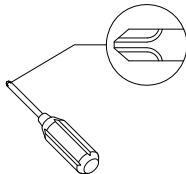



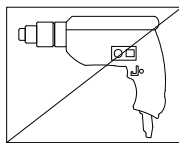





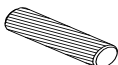



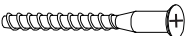

- VII. Power tools should not be used to assemble this product .

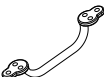

- IX. Surface should be uniform during assembly process.
- X. While door assembly ,ensure gap on all Four sides are equal.
- XI. Mallet can be used to drive in dowel.

Hardware List

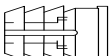
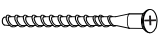
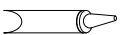
Sr. No.	IMAGE	PART NAME	SIZE	QTY
A		Wooden Dowel	∅8x40mm	37 Nos
B		Minifix Twister	6x35mm	23 Nos
C		Minifix Roster	∅15x12mm	23 Nos
D		Minifix Cap	∅15mm	23 Nos
E		Shoulder Screw	∅6x50mm	10 Nos
F		Screw	∅3x30mm	04 Nos
G		Screw	∅3x16mm	56 Nos
H		Shelf Pin	∅8x∅5x16mm	12 Nos
I		PVC Connector	31mmx21mmx21mm	07 Nos
J		Wheel Bracket Big	215mmx25mmx18mm	04 Nos
K		Wheel Bracket Small	72mmx25mmx02mm	04 Nos
L		Sliding Rail	1284mmx19mmx32mm	01 Nos
SH		Shutter Handle		02 Nos
M		PVC Sleeve	∅ 5X10	60 pcs
N		Minifix Socket	∅ 8x13mm	23 pcs
O		Shoulder Screw	∅3x45mm	03 Nos
P		Glue Tube		01 Nos

Note: **PVC SLEEVE AND MINIFIX SOCKET ALREADY FIXED.
IN SOME CASES MINIFIX ROSTER ARE ALREADY FIXED.**

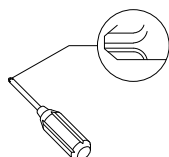

Philips head screwdriver required for assembly
(not included)

PARTS LIST

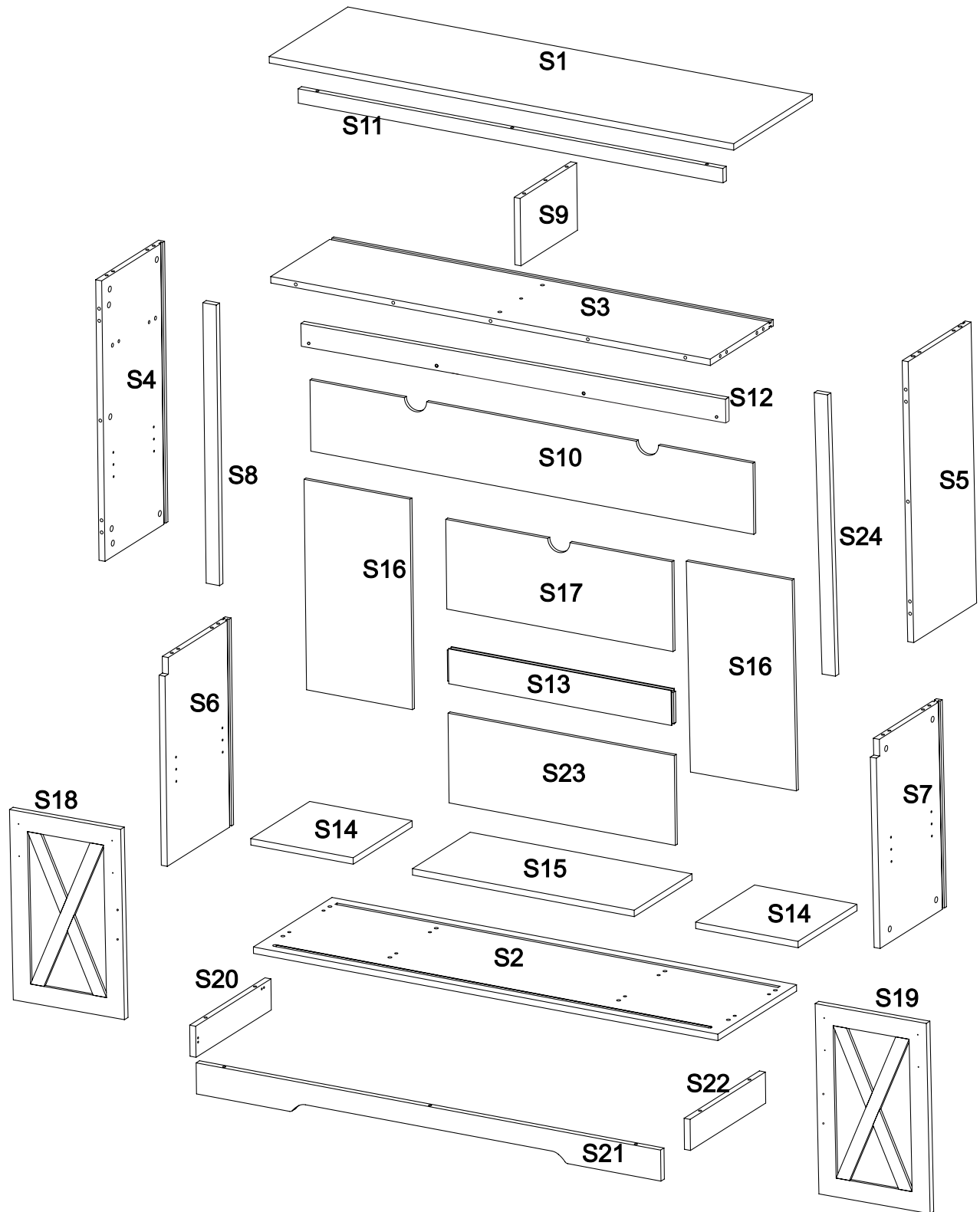

Step 1

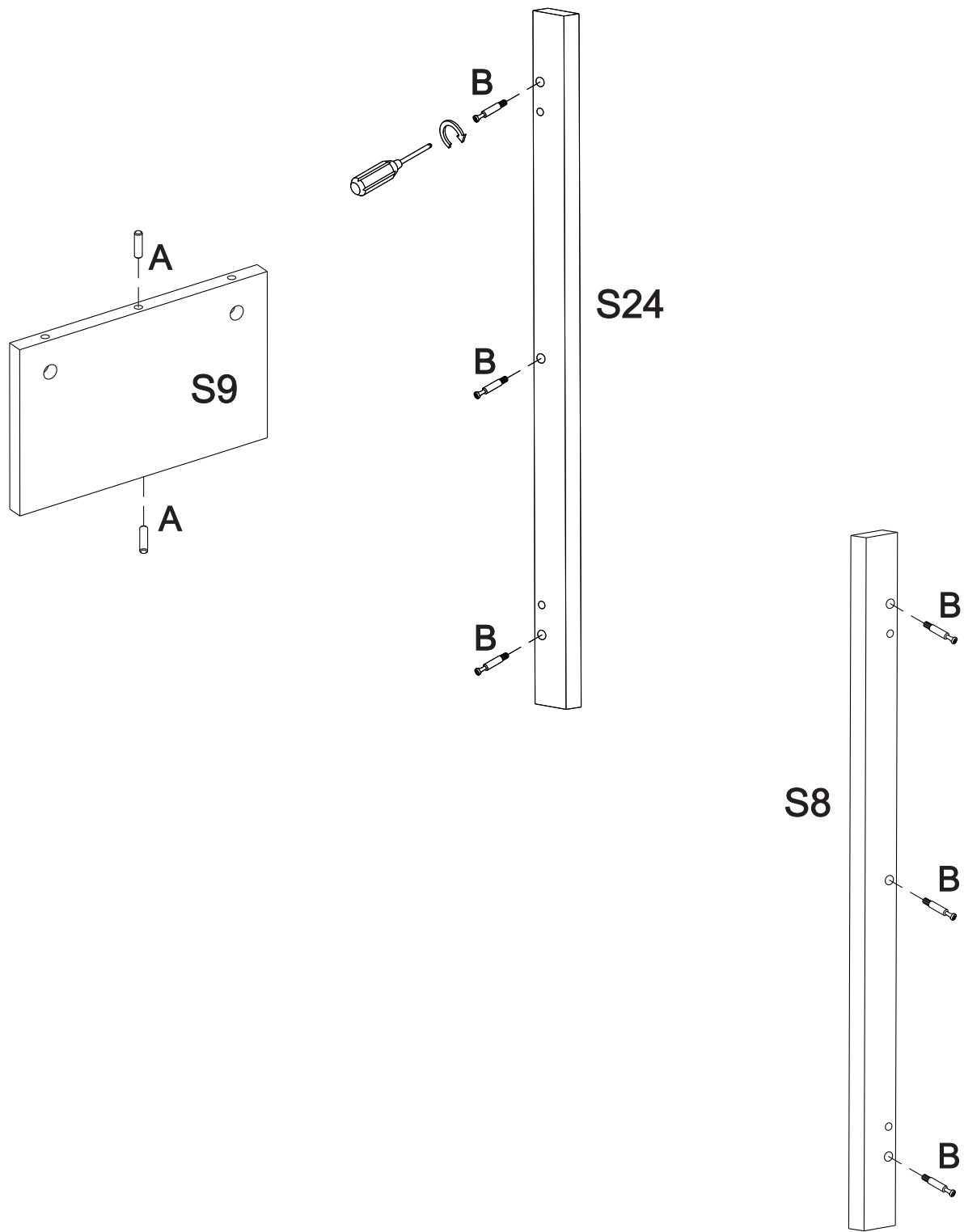

Attach Minifix twister (B) to part (S24, S8) with screwdriver.
Insert Dowel (A) into part (S9).

Step 2

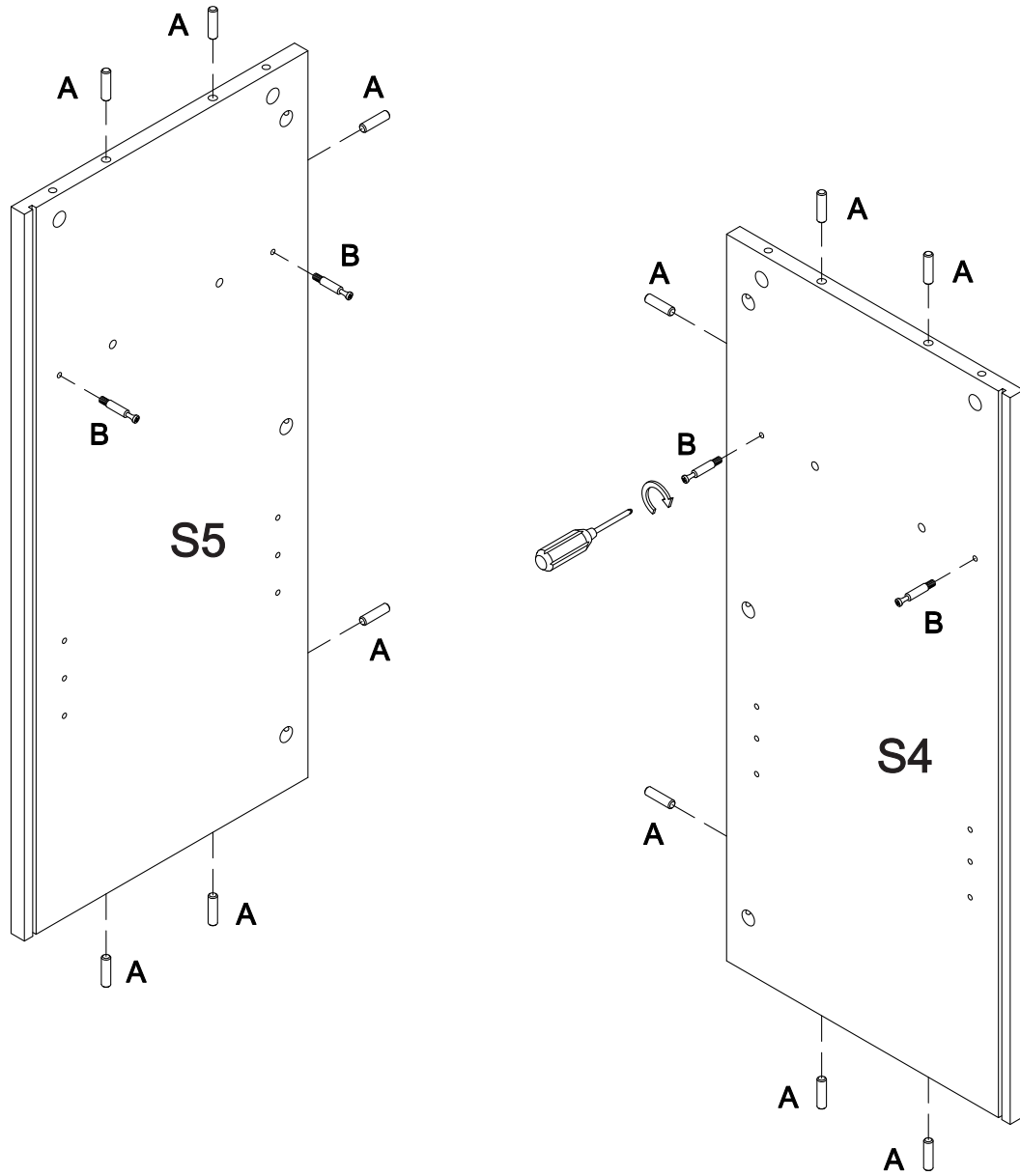

Part (A) should be fix in blind holes.

Insert wooden dowel (A) into part (S4,S5).

Attach Minifix Twister (B) to part (S4,S5) with screwdriver.

Step 3

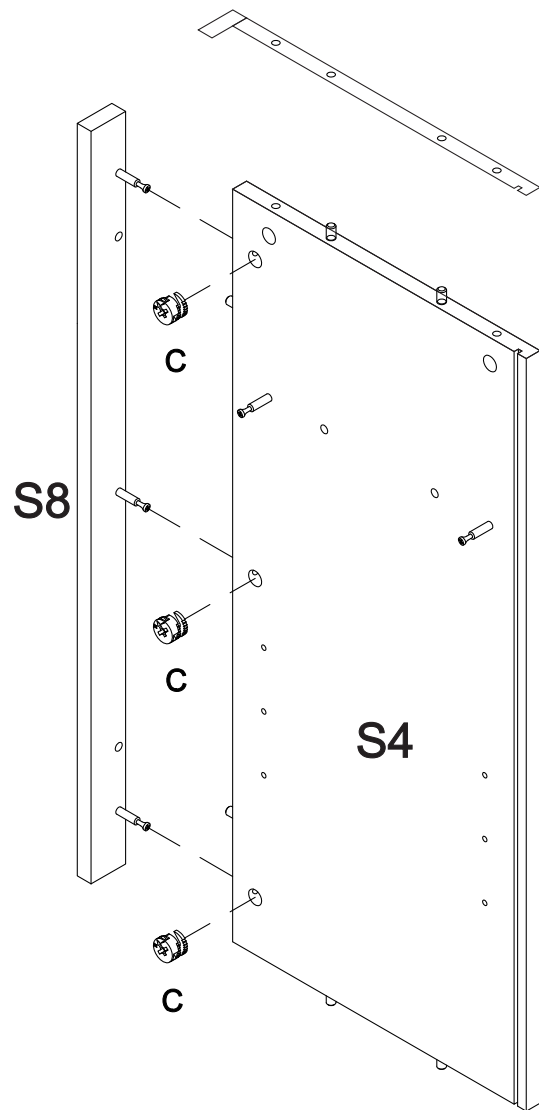
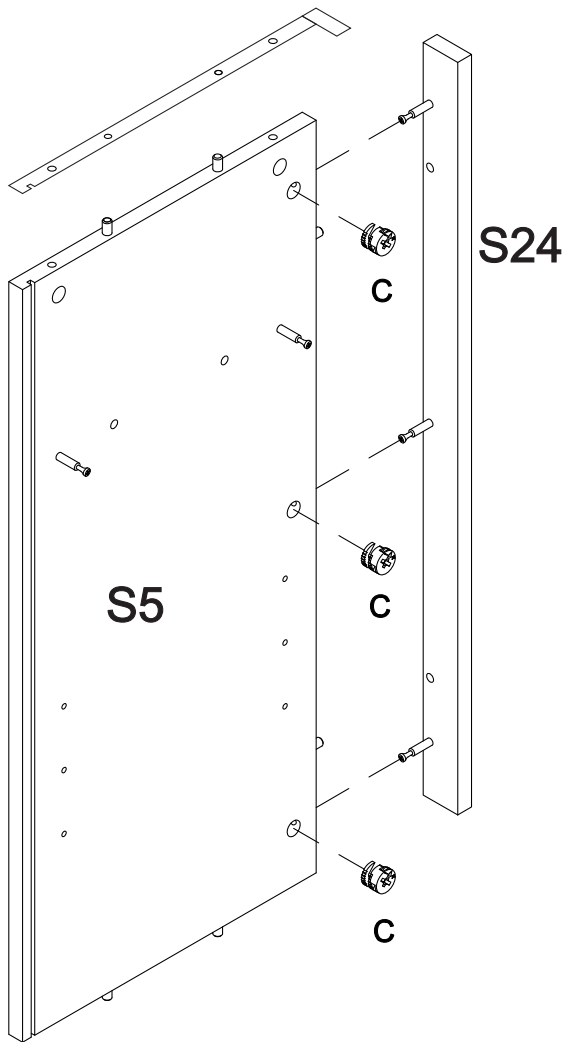
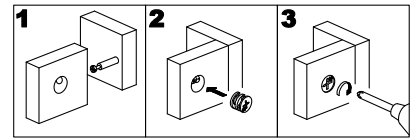

Attach part (S8, S24) to part (S4,S5), then insert and secure Minifix Roster (C) to part (S4,S5)

Step 4

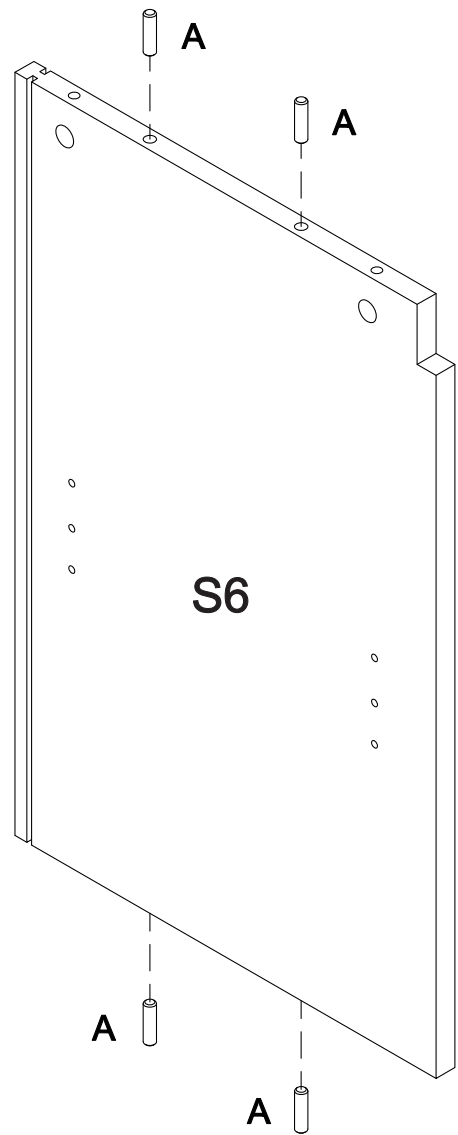
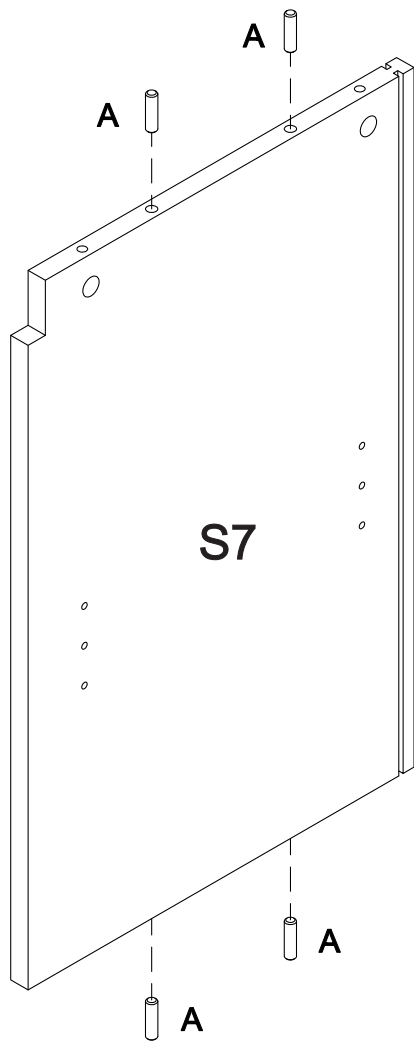

Insert wooden dowel (A) into part (S6, S7).

Step 5

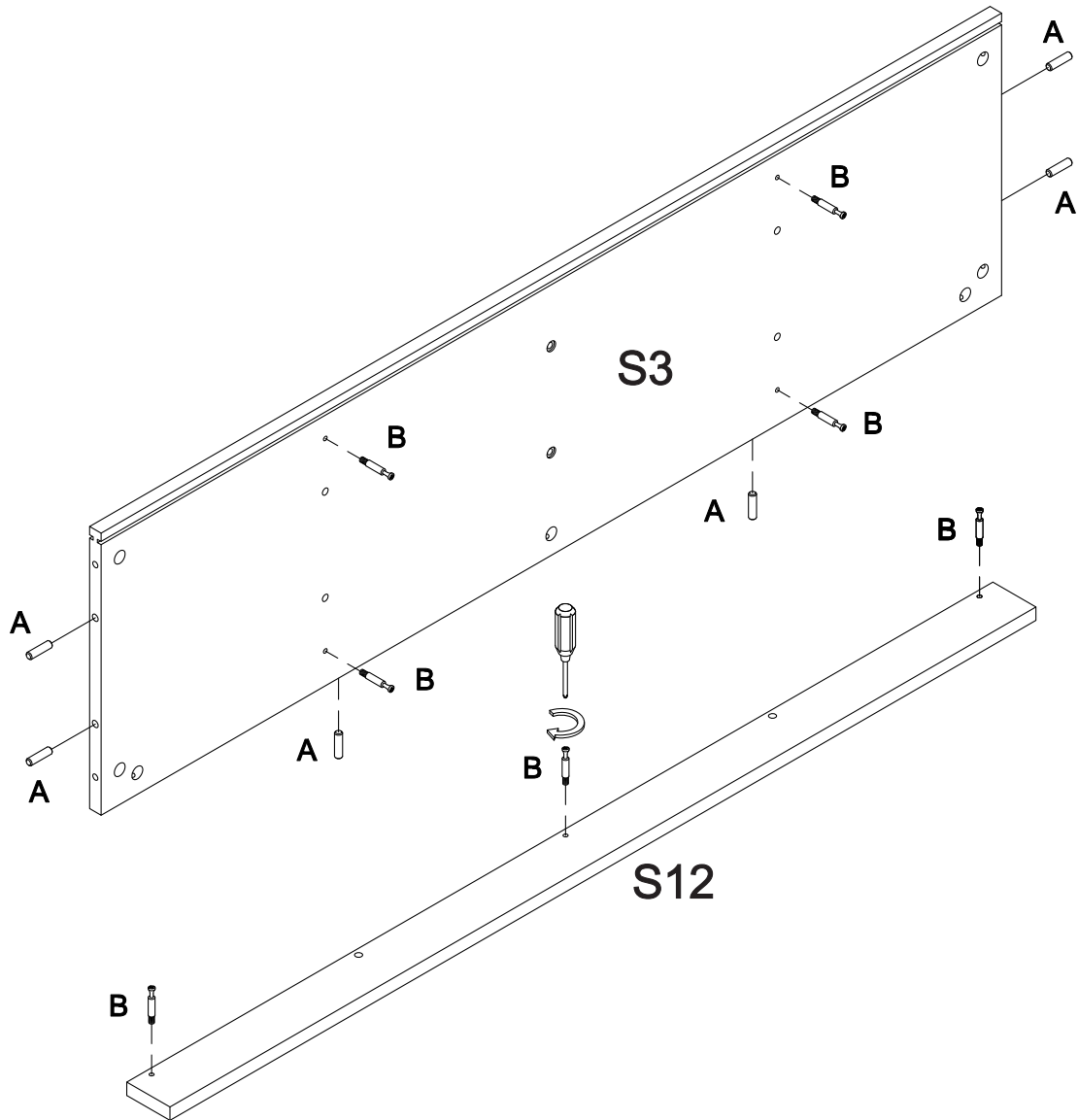

Attach Minifix Twister (B) to part (S12,S3) with screwdriver. Insert wooden dowel (A) into part (S3).

Step 6

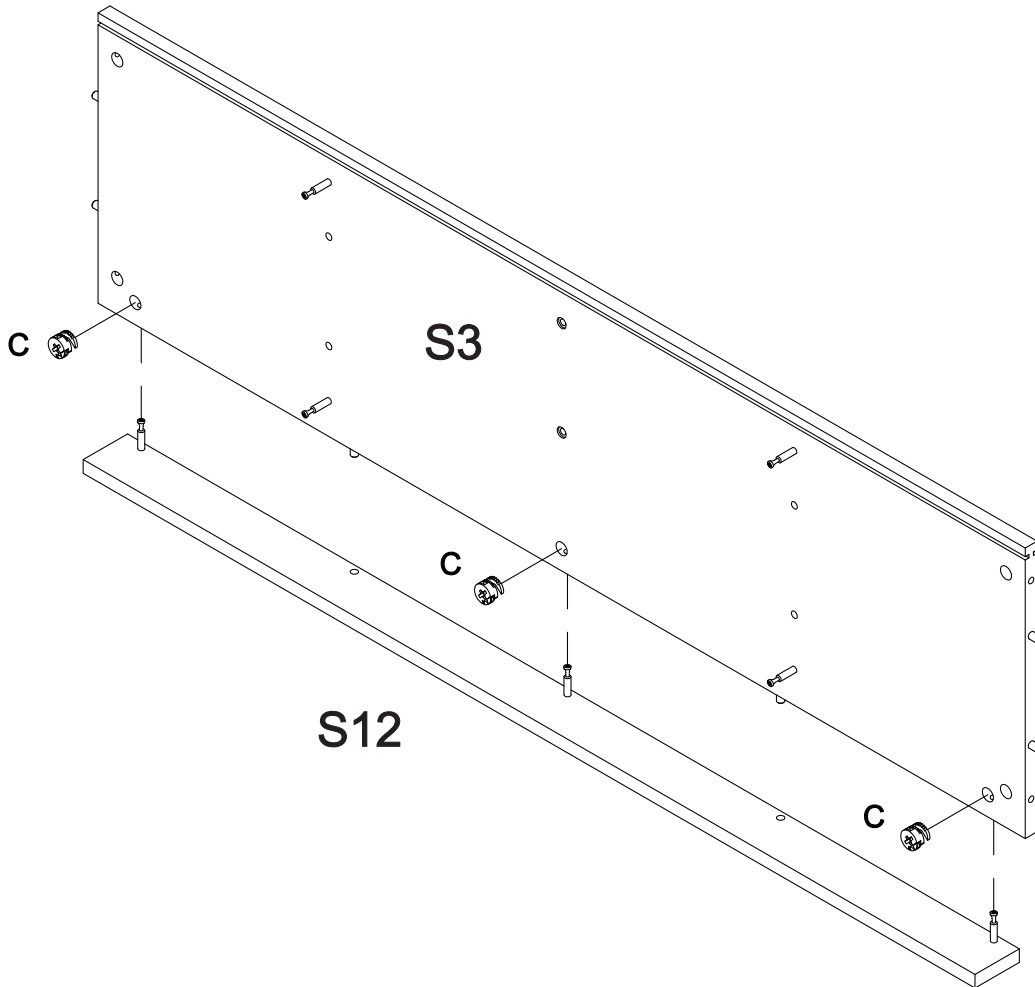
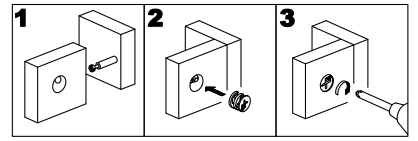

Attach part (S12) to part (S3), then insert and Minifix Roaster (C) to part (S3) to lock it.

Step 7

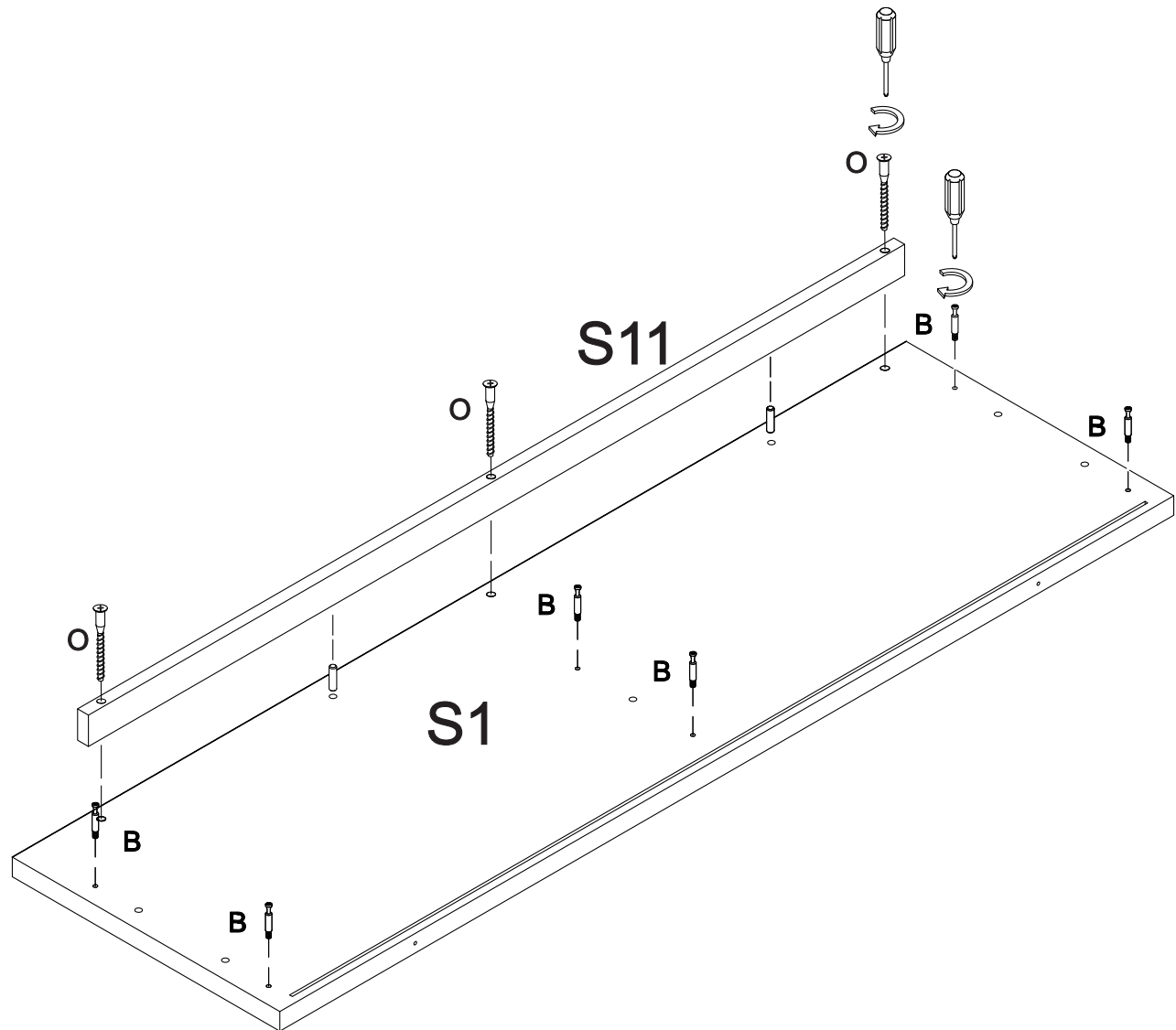

First fix dowel (A) in part (S1)
Then Attach part (S11,S1) with screw (O).
Insert Minifix Twister (B) to part (S1)with screwdriver.

Step 8

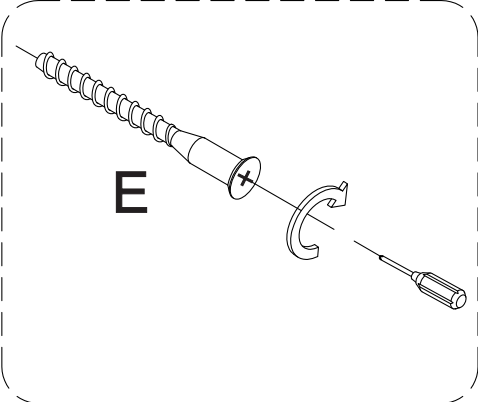

Edge Bend Side

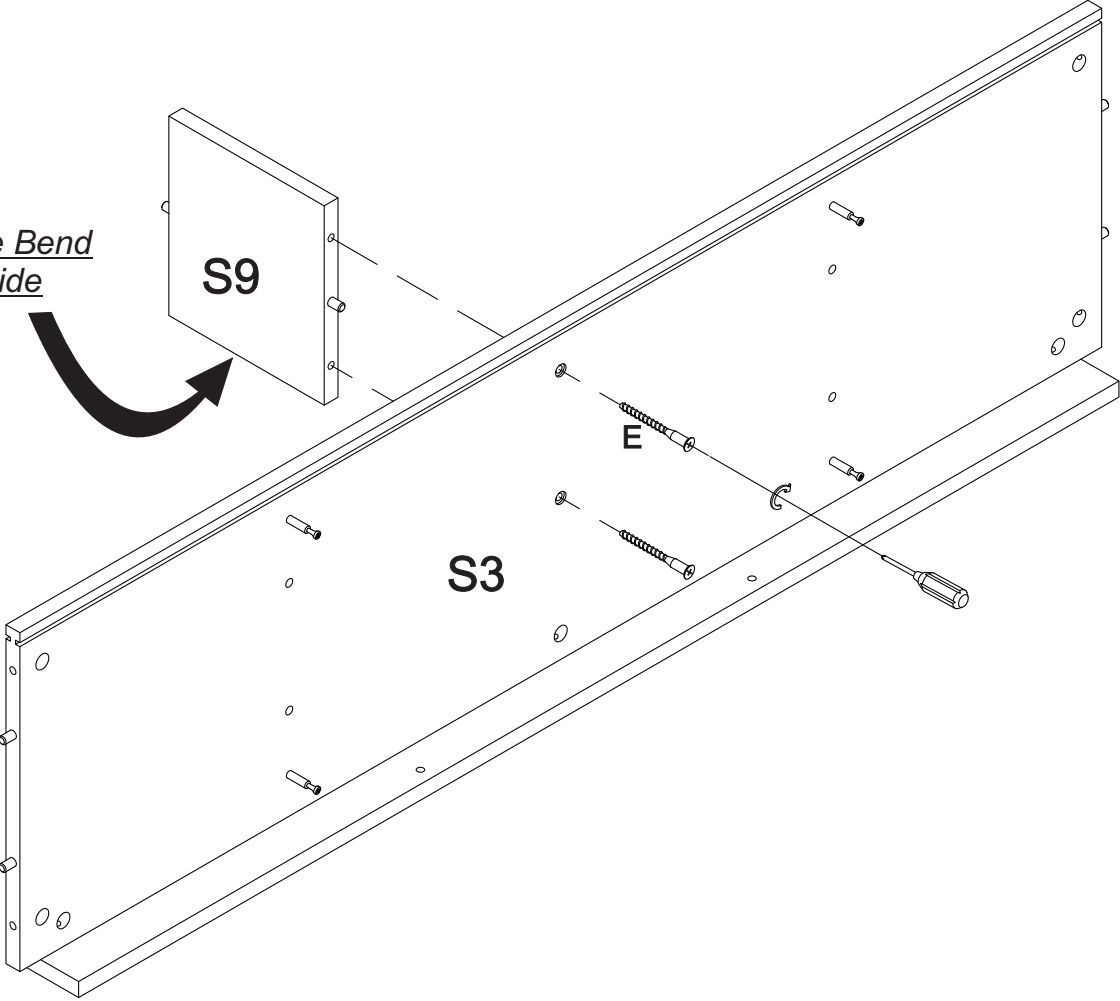

Attach part (S9) to part (S3) using bolt (E) with Screwdriver.

Step 9

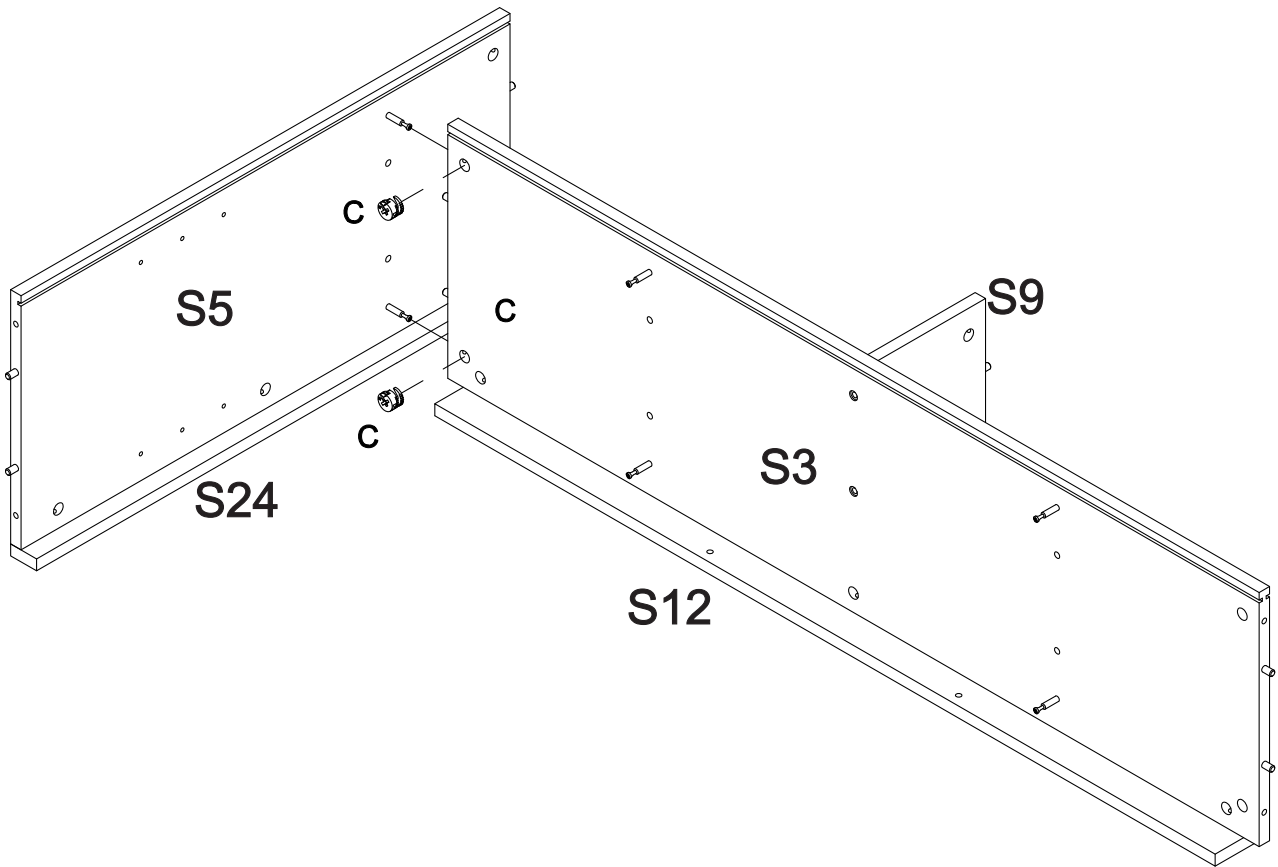
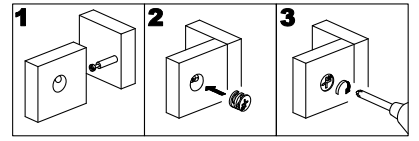

Attach part (S5,S24) to part (S3,S12) then insert Twister Roster (C) in part (S3, S12) and secure to lock it.

Step 10

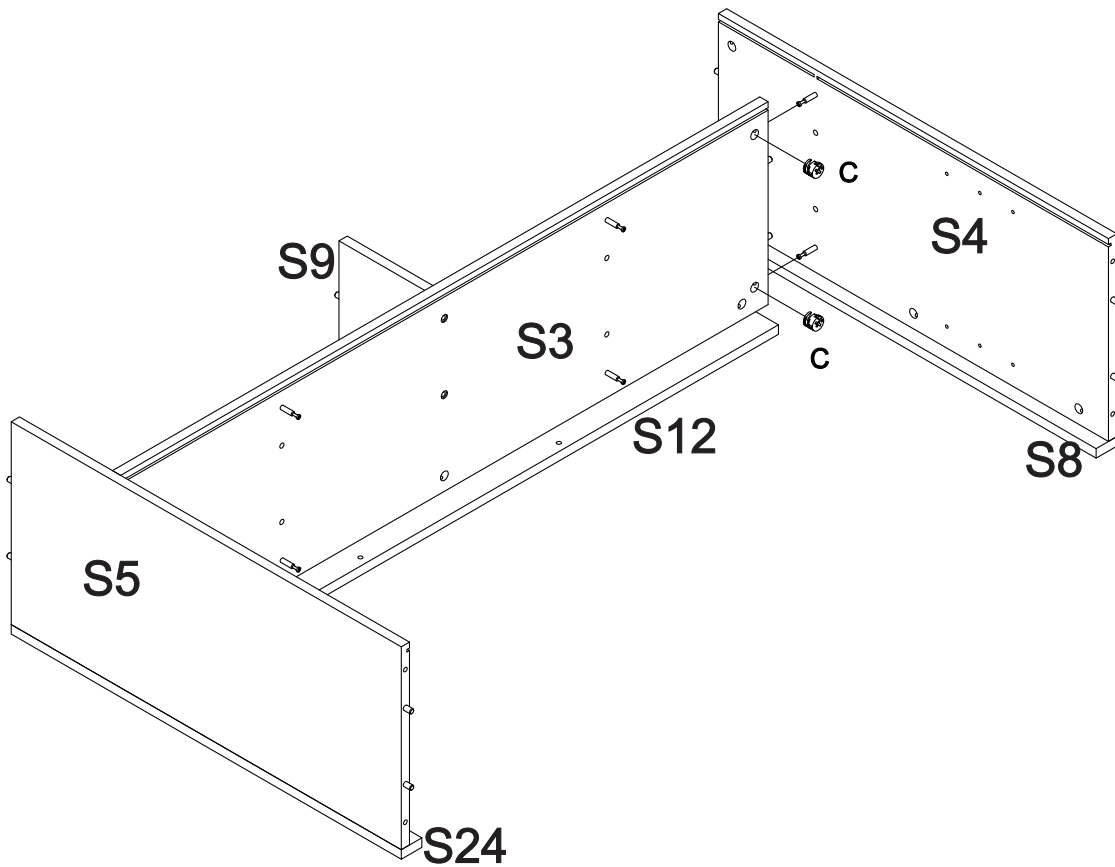
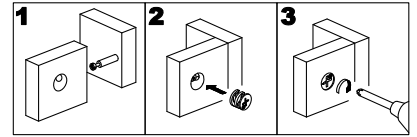

Attach part (S4,S8) to part (S3,S12) then insert Minifix Roster(C)
in part (S3,S12) and secure to lock it

Step 11

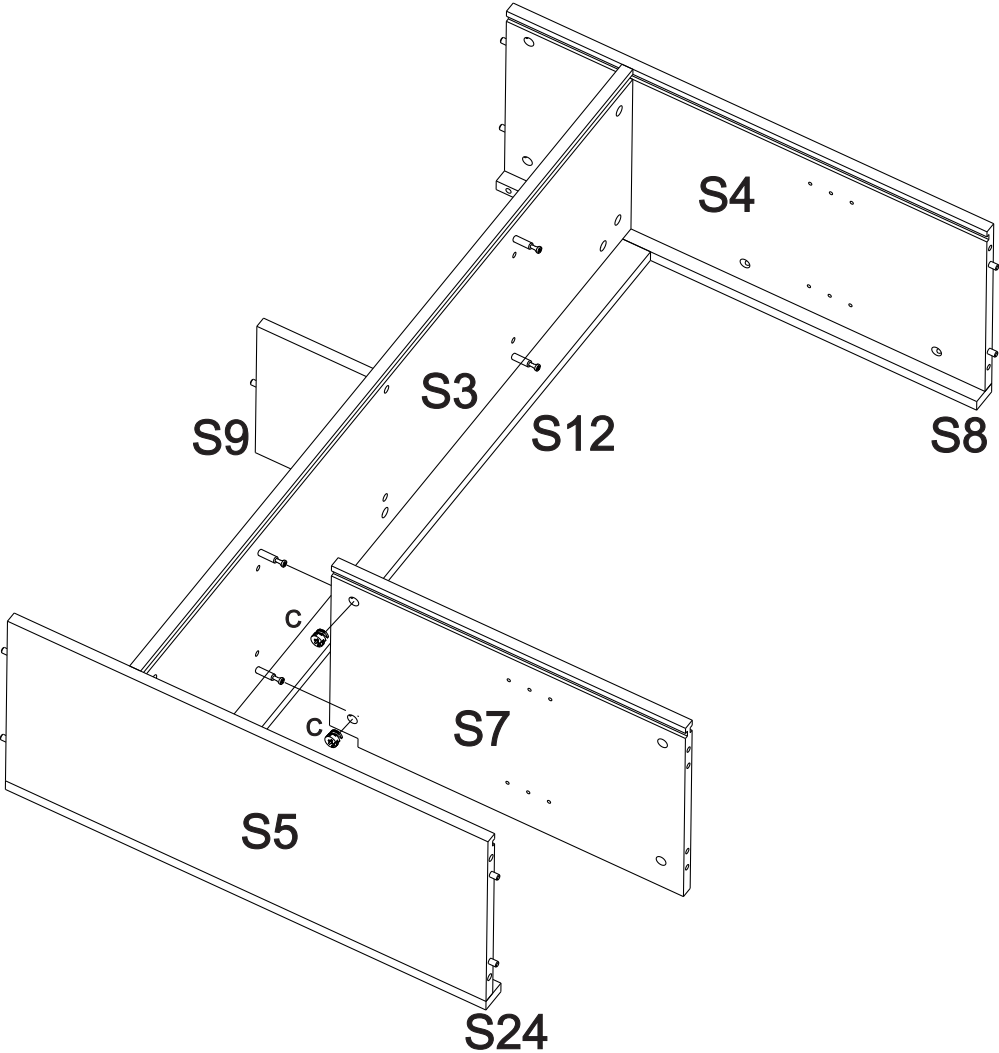
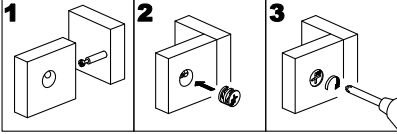

Attach part (S7) to part (S3) by Minifix Roster (C) to secure to lock it tightly.

Step 12

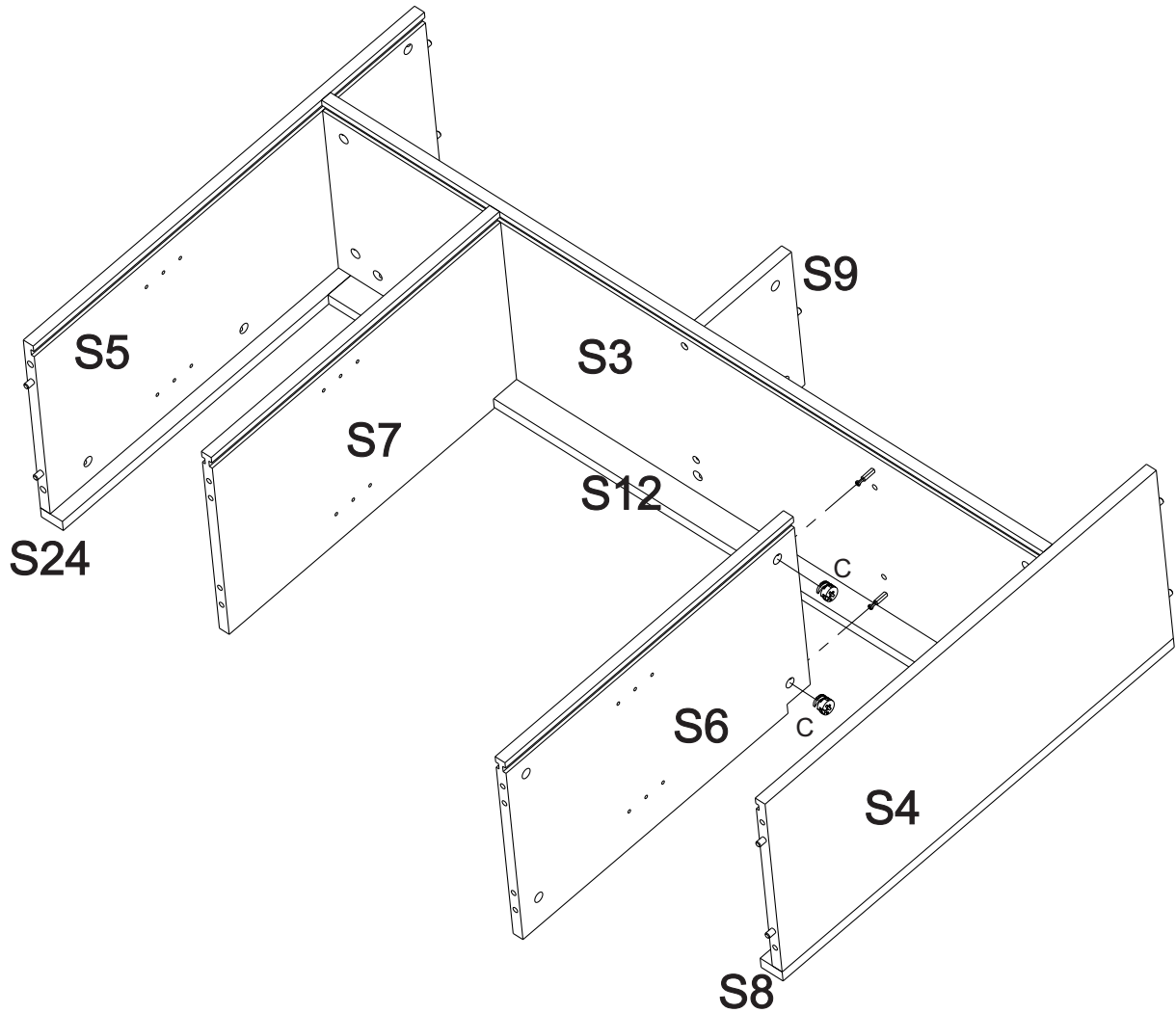
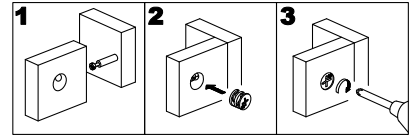

Attach part (S6) to part (S3) by Minifix Roster (C) to secure to lock it tightly.

Step 13

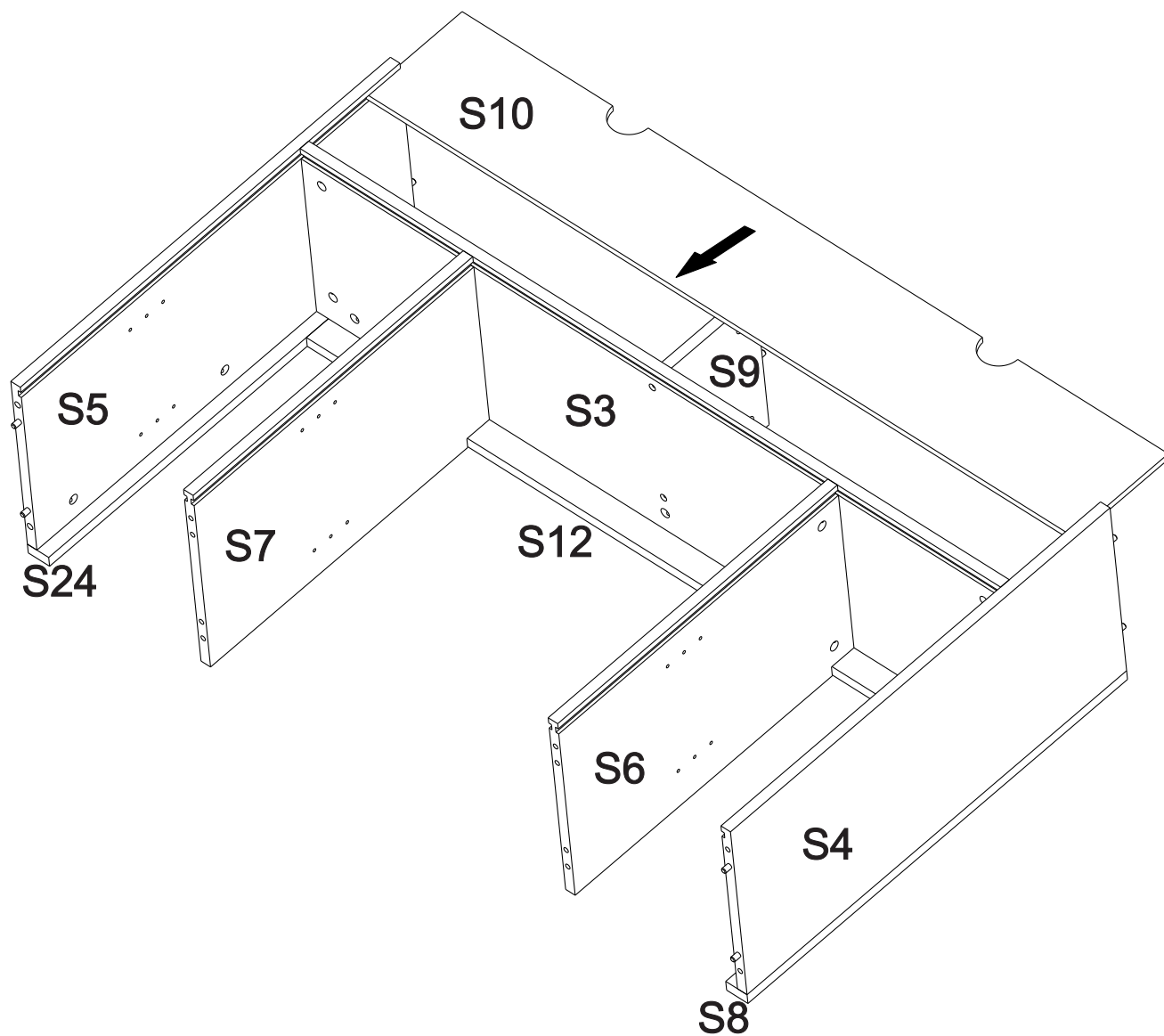

Slide back panel (S10) into grooves as per diagram.

Step 14

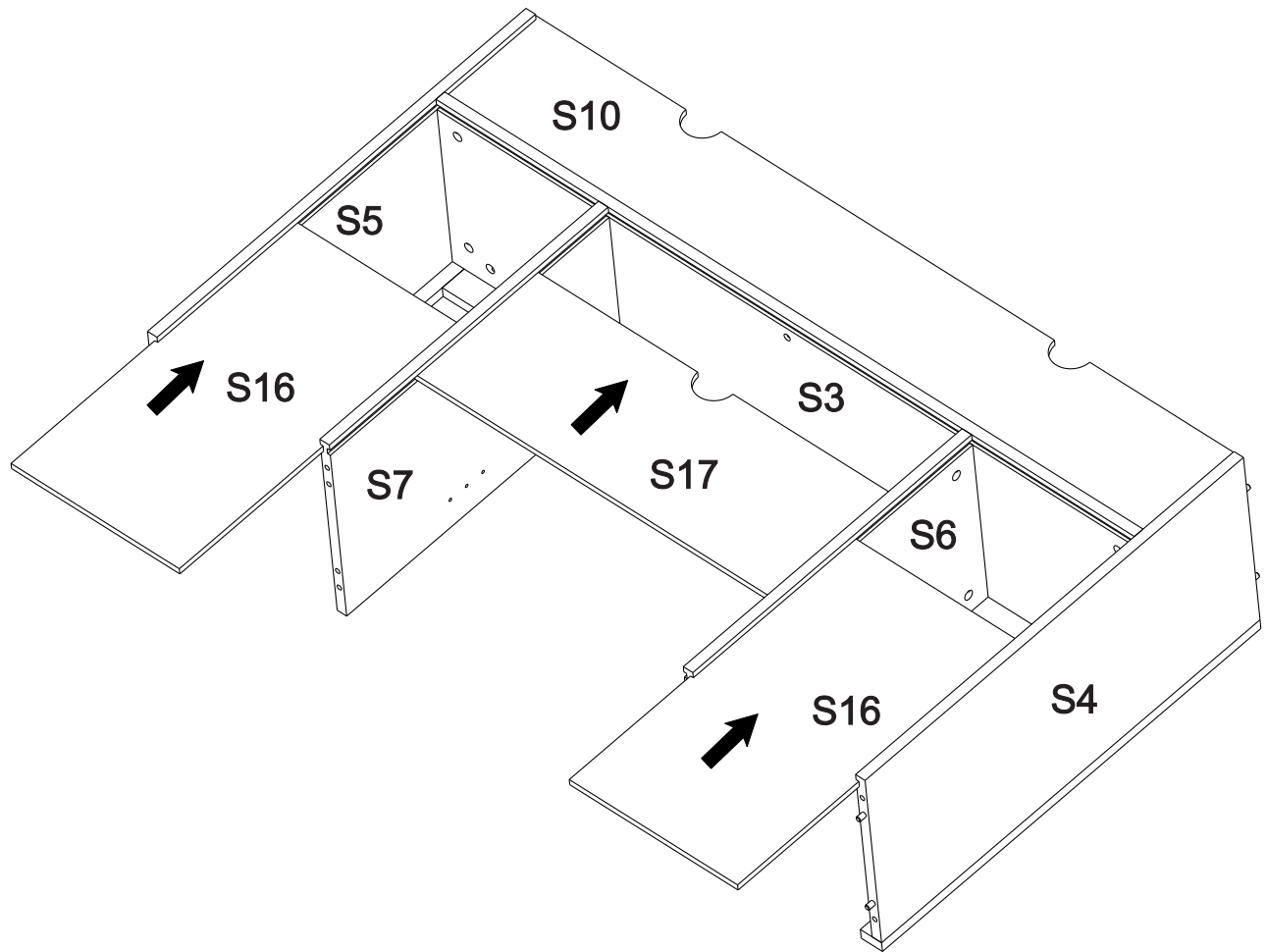

Slide back panel (S16, S17) into grooves as per diagram.

Step 15

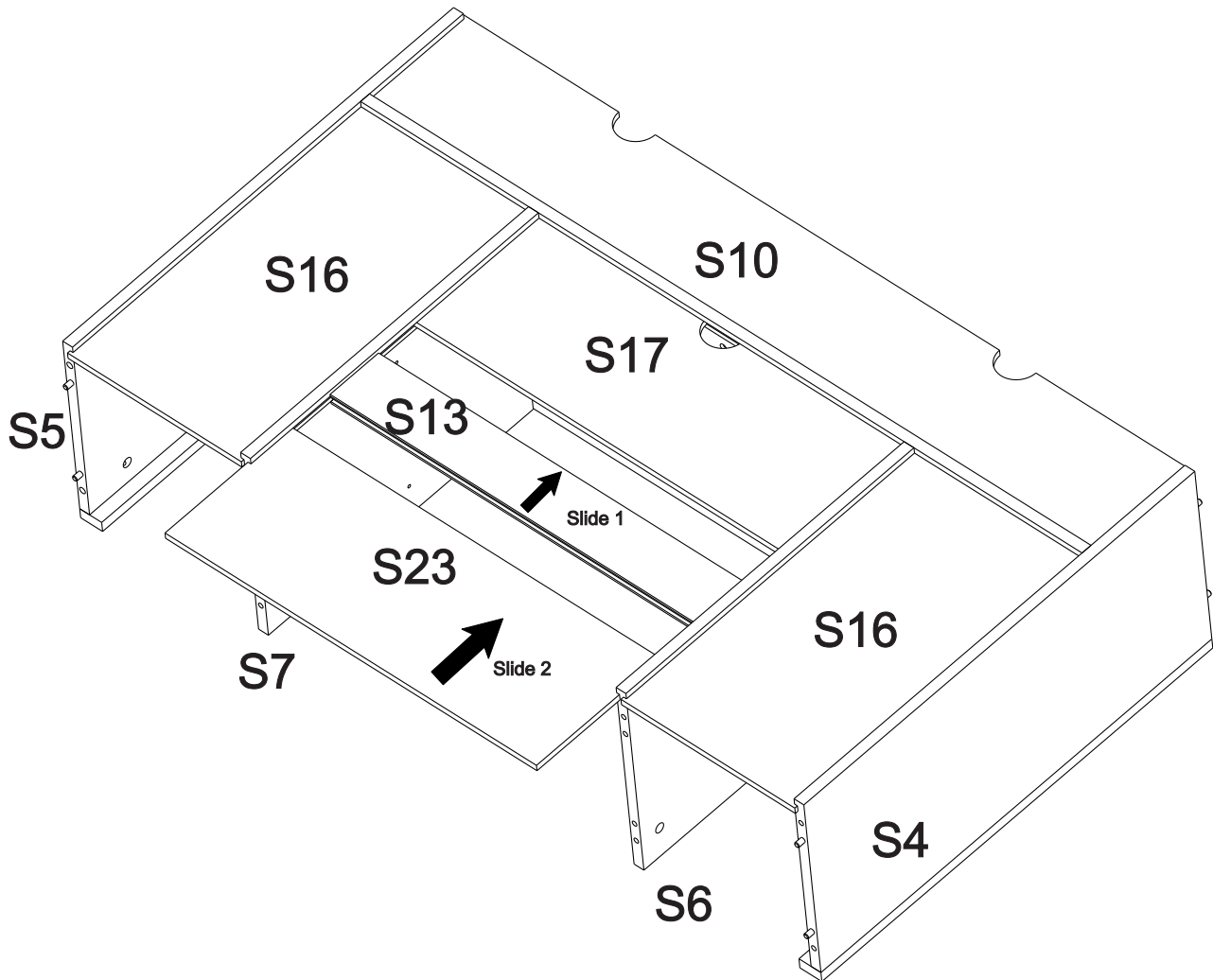

First - Attach part (S13) to part (S17) by sliding into Grooves.
Second - Attach part (S23) to part (S13) by sliding into Grooves.
After Fixing bottom side Up.

Step 16

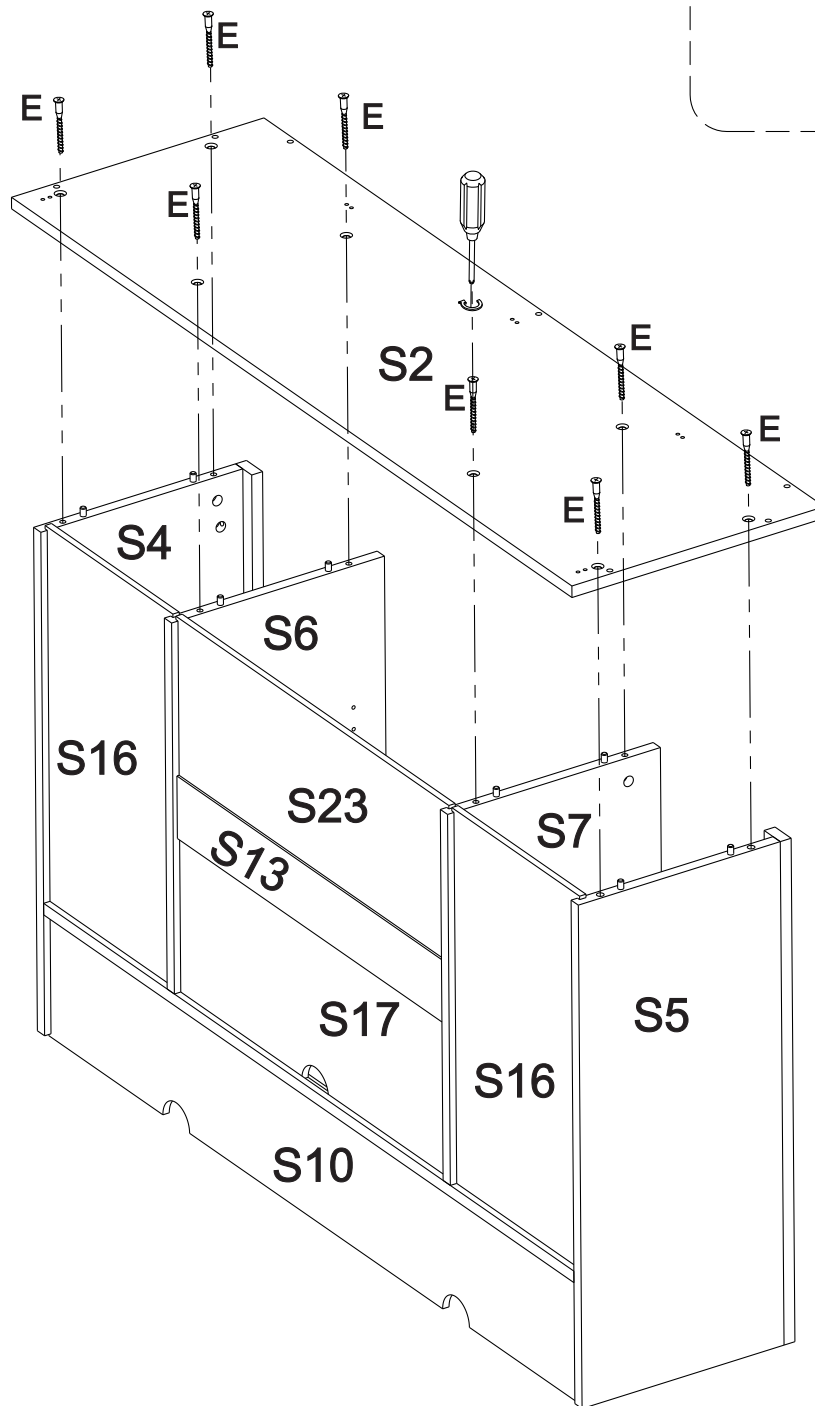
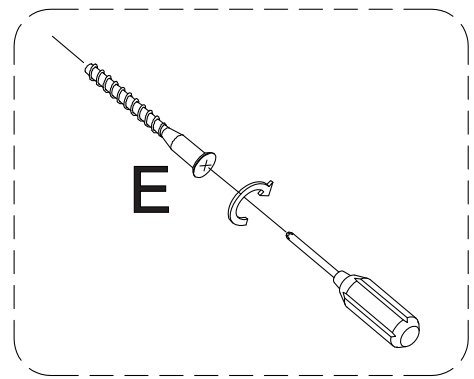

Attach part (S2) to part (S4,S6,S7,S5) using Screw (E) with Screw Driver.

Step 17

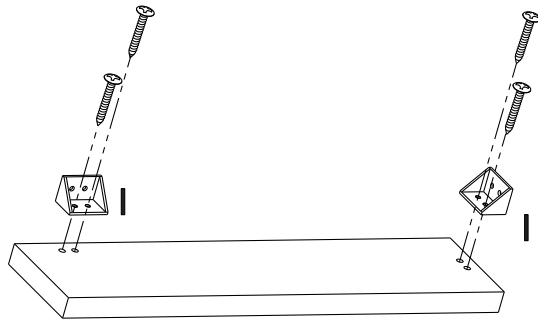

S22

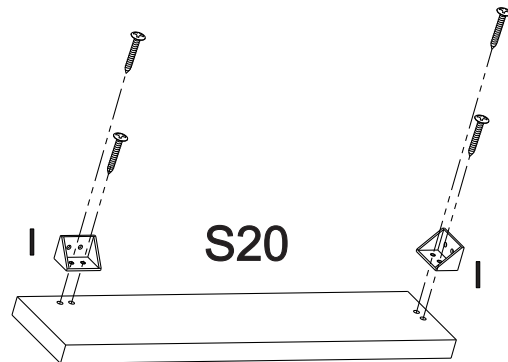

S20

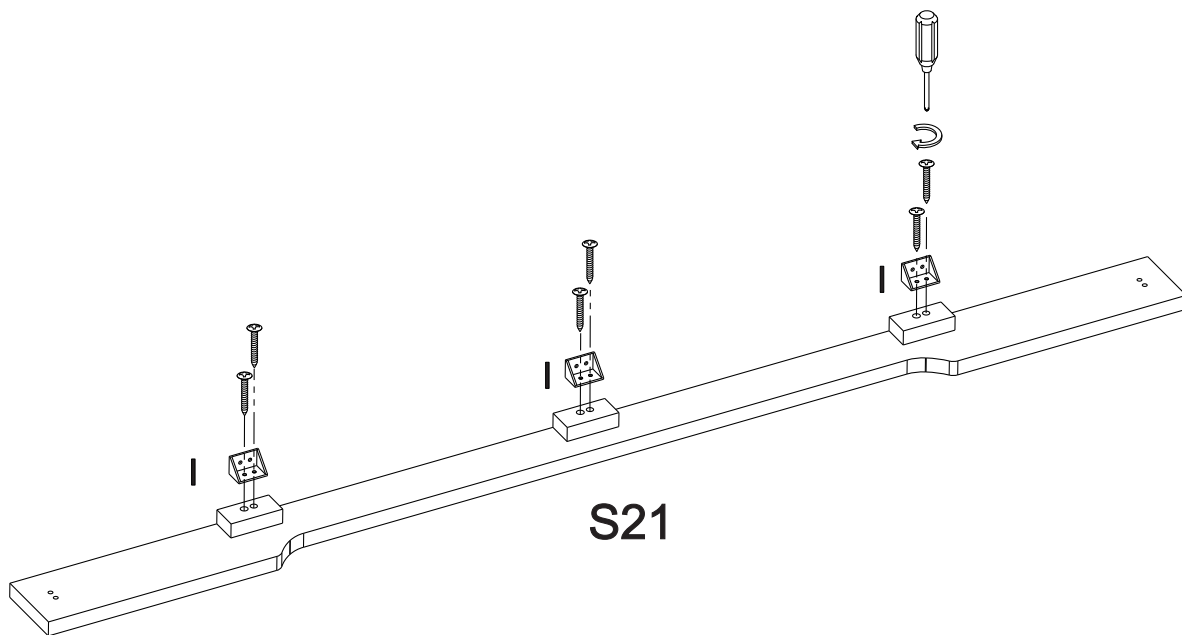

S21

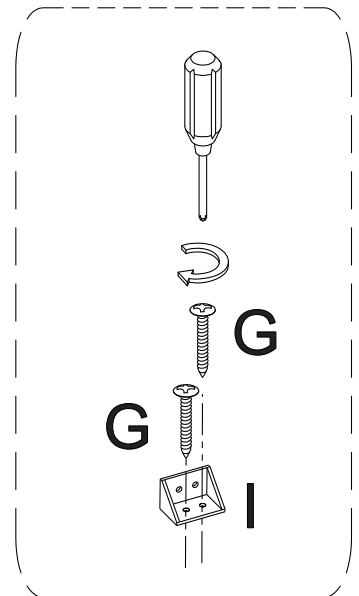

Attach connectors (I) to part (S22,S20,S21) using Screw (G) with Screw Driver.

Step 18

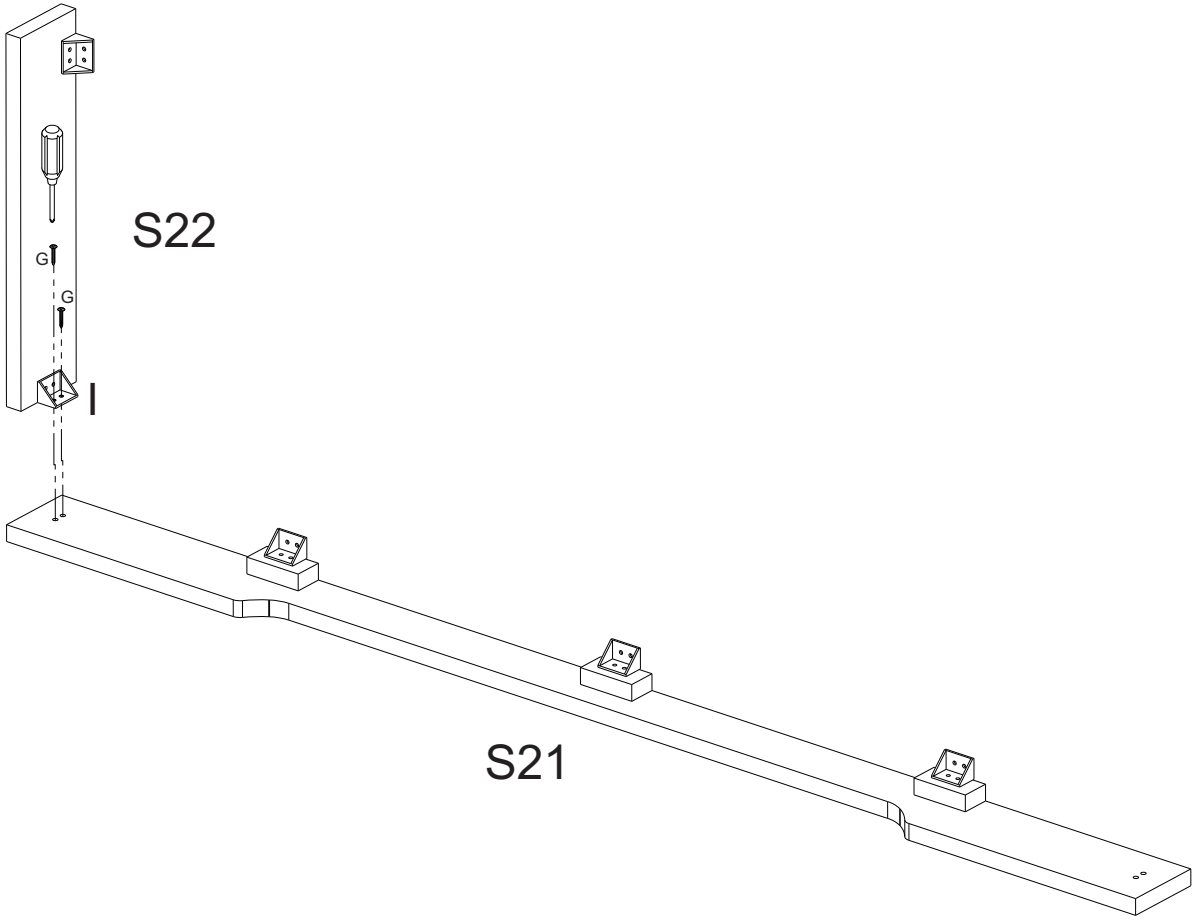
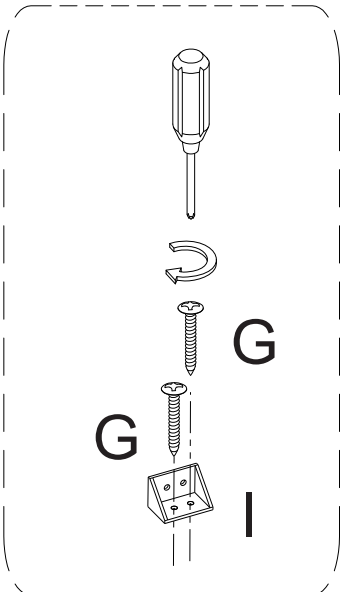

Attach part (S22) to part (S21) using Screw (G) with Screw Driver.

Step 19

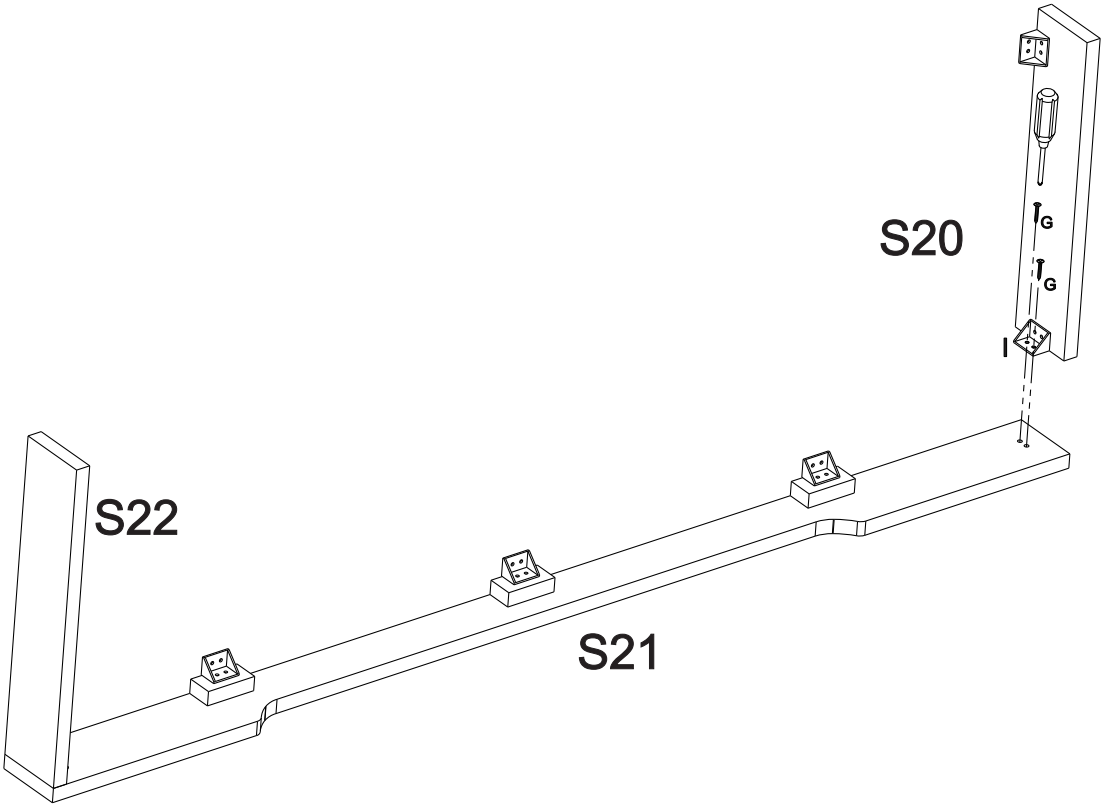
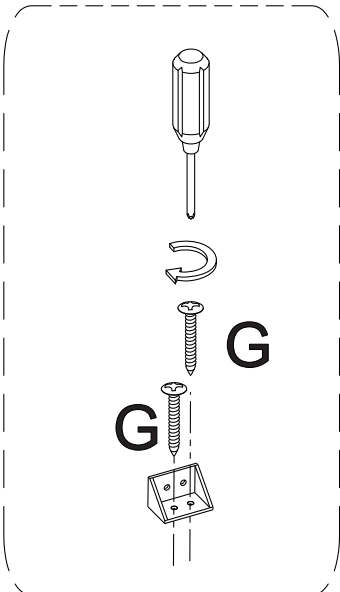

Attach part (S20) to part (S21) using Screw (G) with Screw Driver.

Step 20

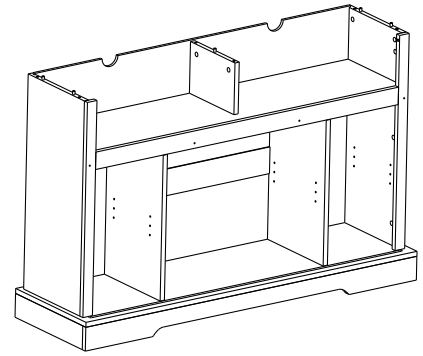
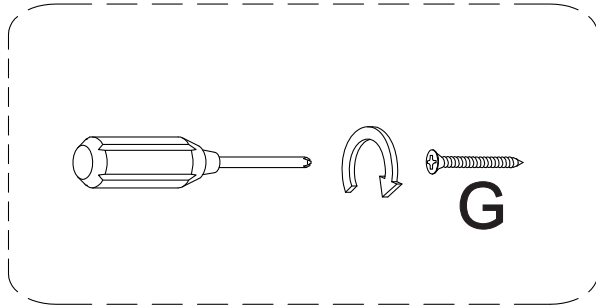

After Fixing Skirting

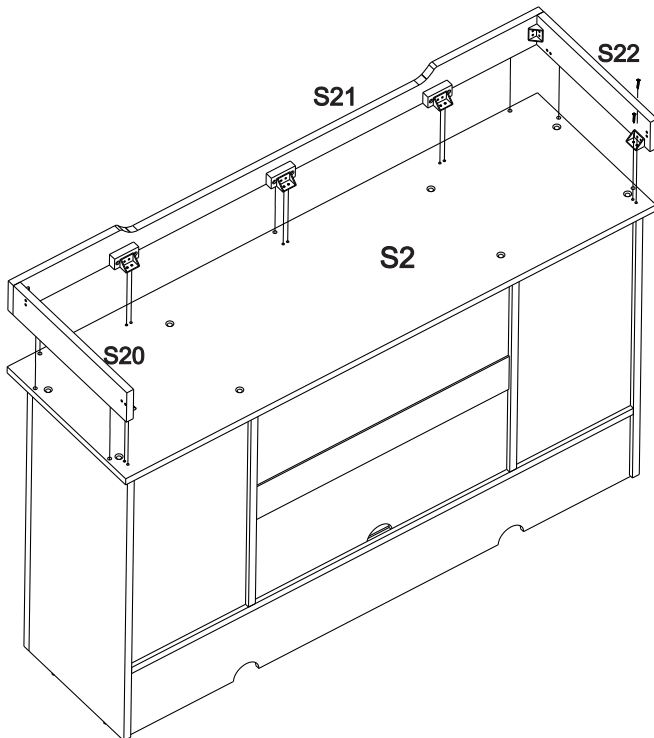
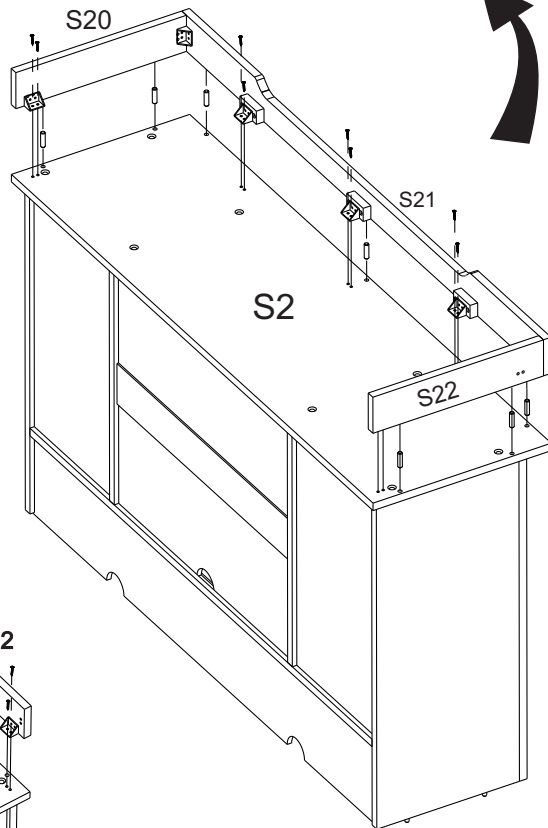

Attach Base unit (S20,S21,S22) to part (S2) using connector (I) with Screw (G) and Screw Driver.

Step 21

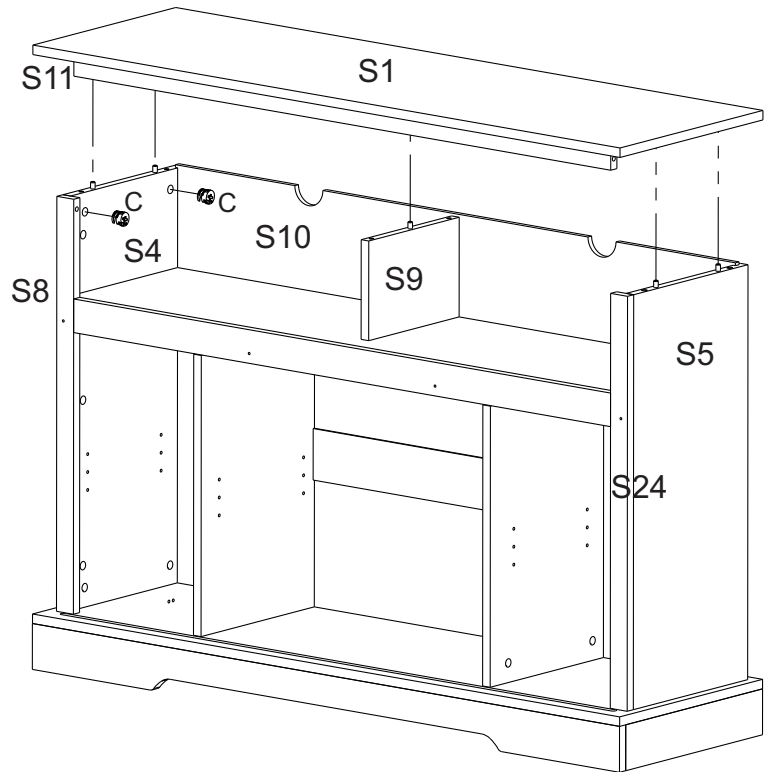
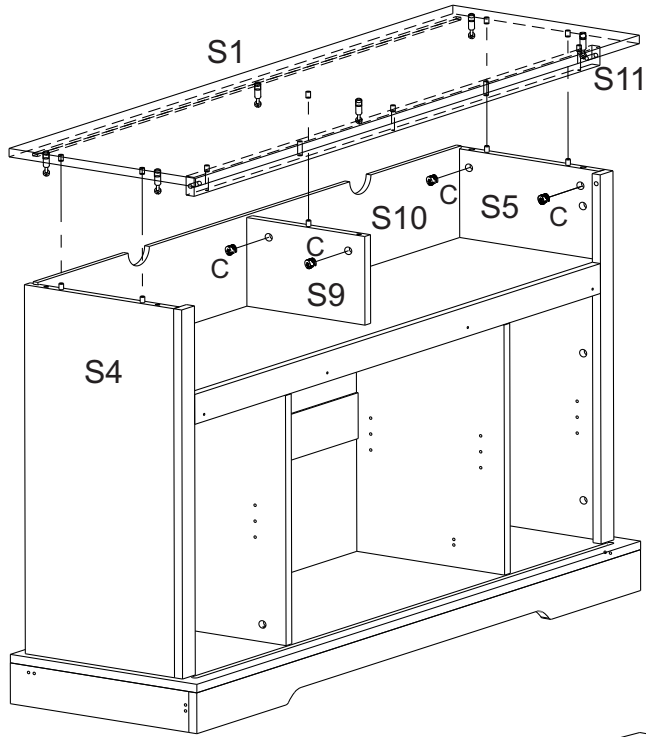
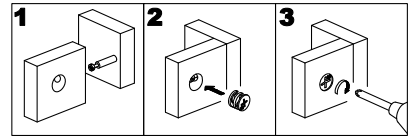

Attach part (S1,S11) part (S4,S5,S9) then insert and secure Minifix Roster (C) to part (S4,S5,S9) to lock it.

Step 22

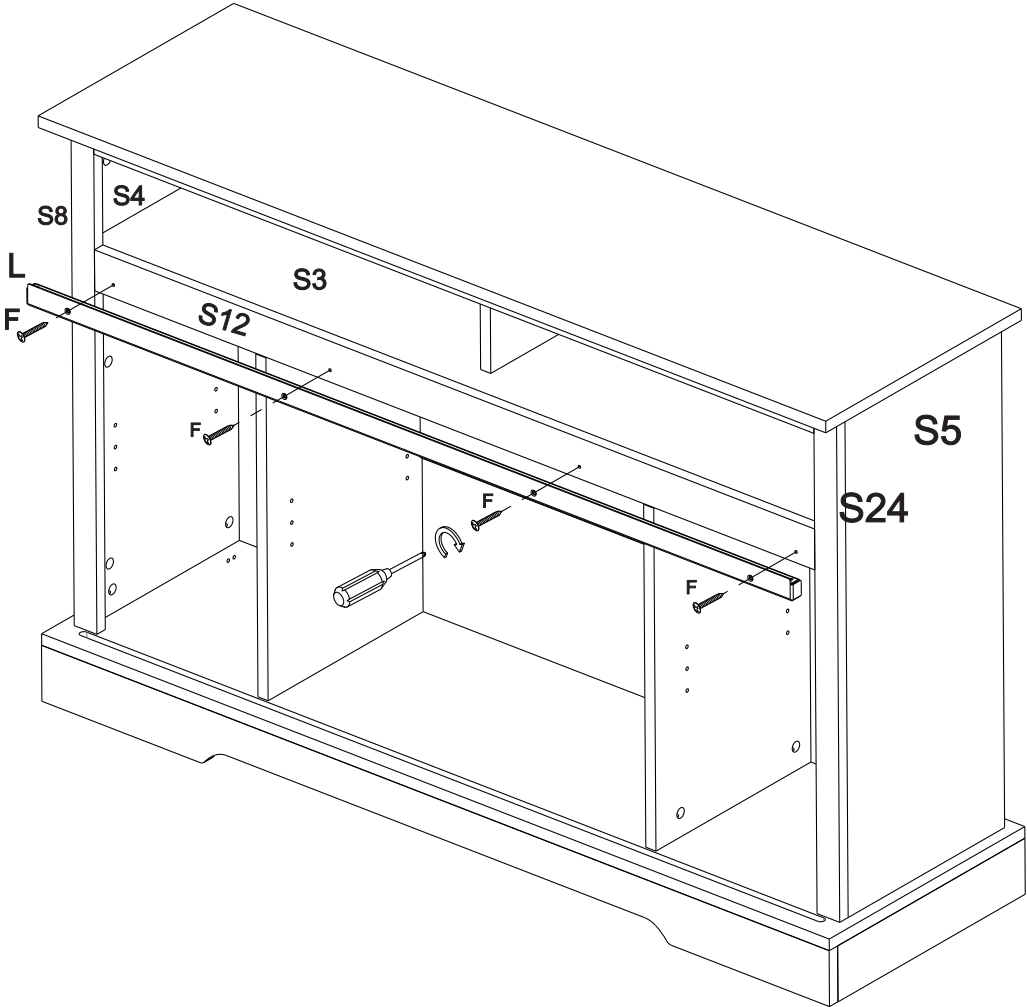
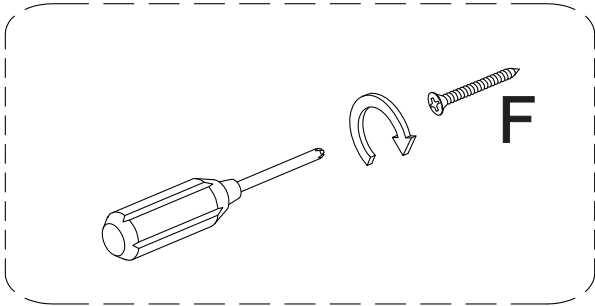

Attach slide Rail (L) to Parts (S8,S12,S24) with screw (E) by screw driver

Step 23

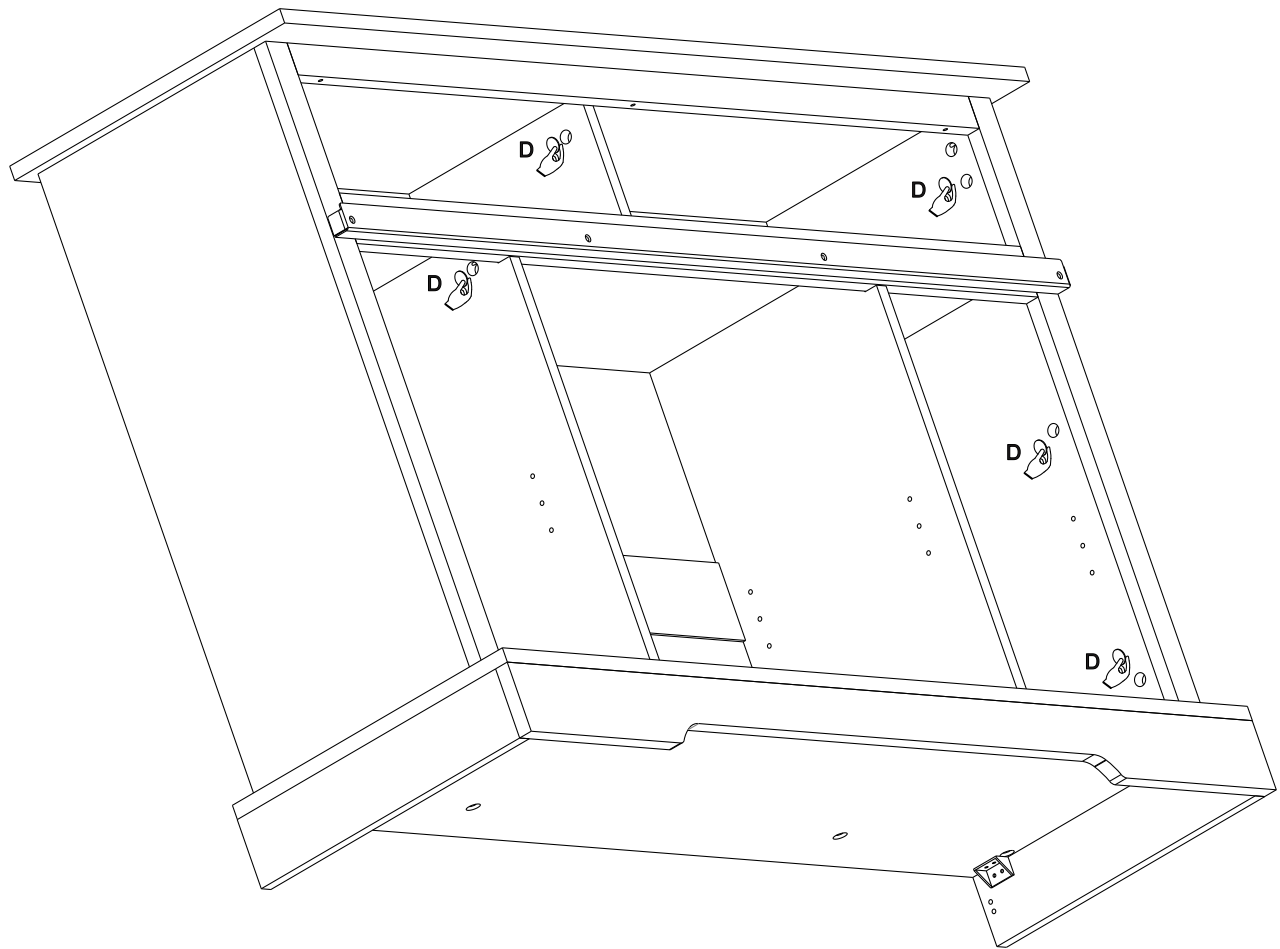

Place Minifix Cap (D) over holes where as Minifix Roster used.

Step 24

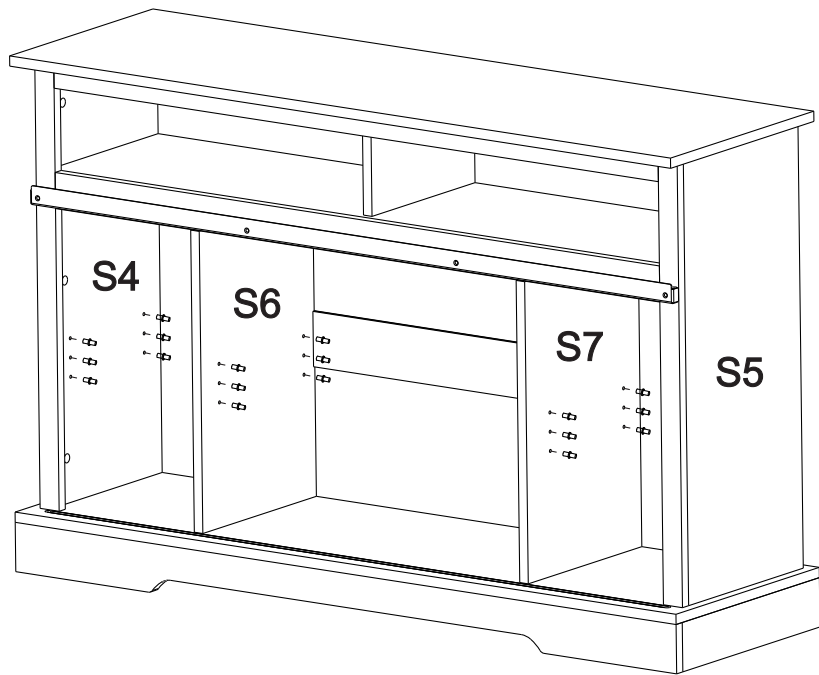
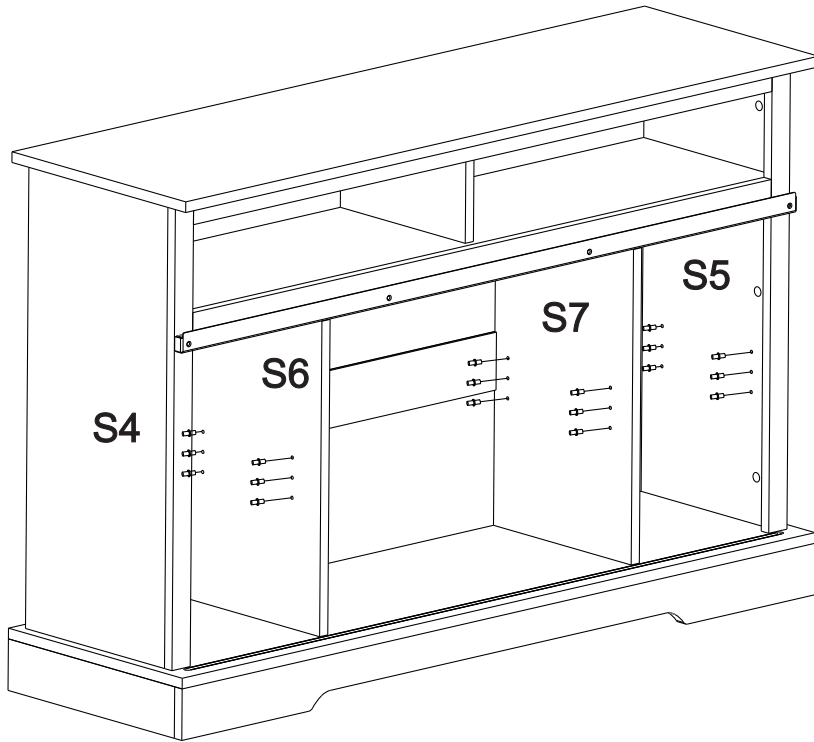
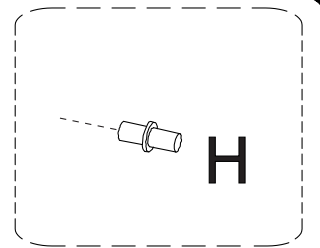

Insert shelf support pin (H) into part (S4,S6,S7,S5)

Step 25

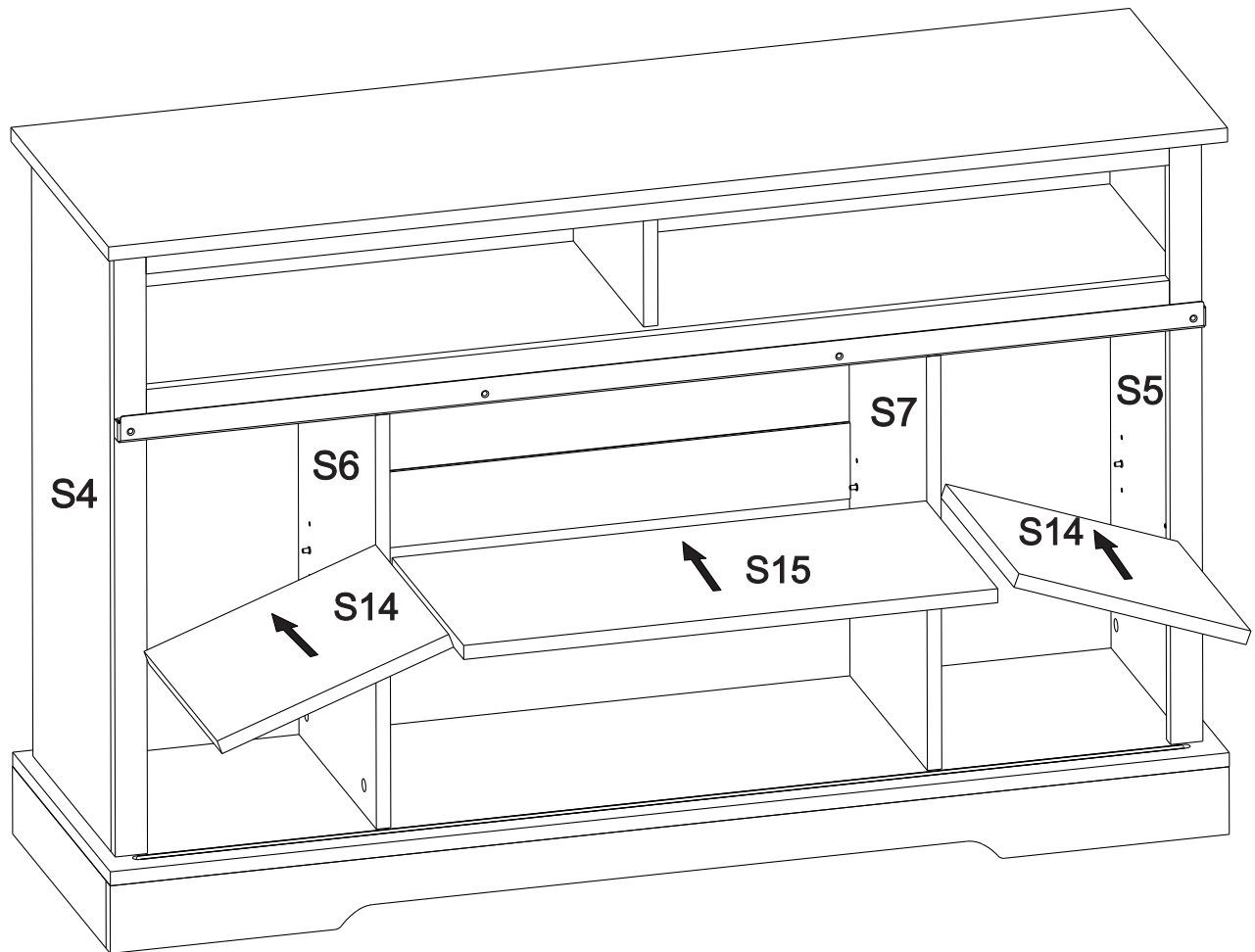

Place shelf (S14,S15) on top of support pins.

Step 26

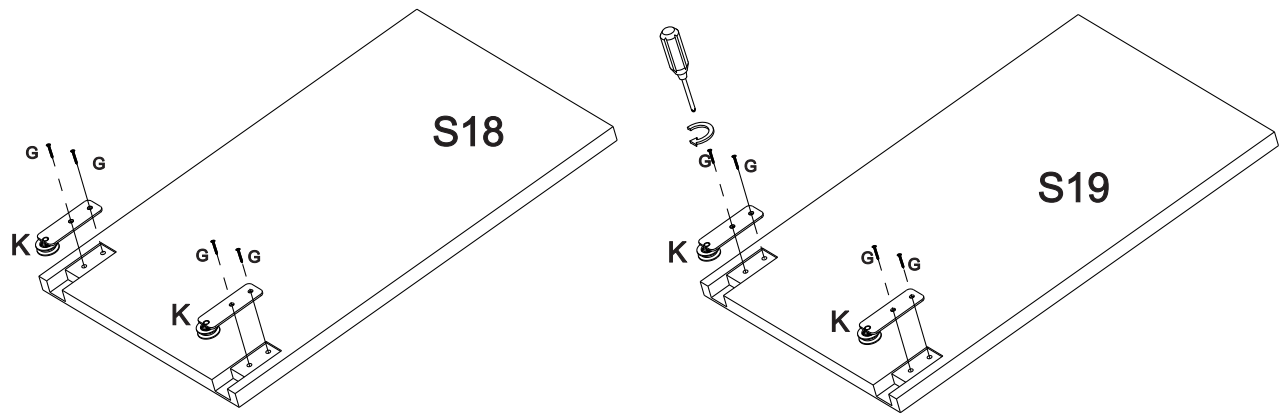

Attach Wheel Bracket small(K) to Parts (S18,S19) with screw (G) by Screw Driver. as above picture.

Step 27

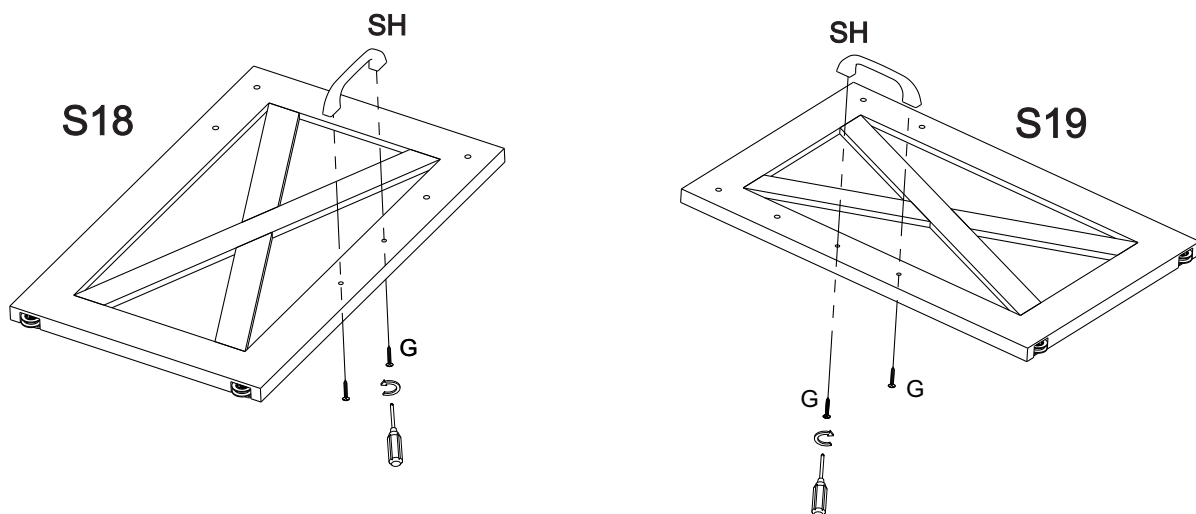

Attach both Screw(G) to Handle(SH) into part(S18,S19) Simultaneously and then tighten with Screw driver as above picture.

Detail Steps

1. Insert screw in one of the hole meant for door handle and turn 1-2 thread only.
2. Insert screw in another hole in door, match the hole in handle and turn 1-2 threads in handle.
3. Once both the screw catch the threads in handle tighten both the screws equally to draw both the ends of handle in simultaneously.

Step 28

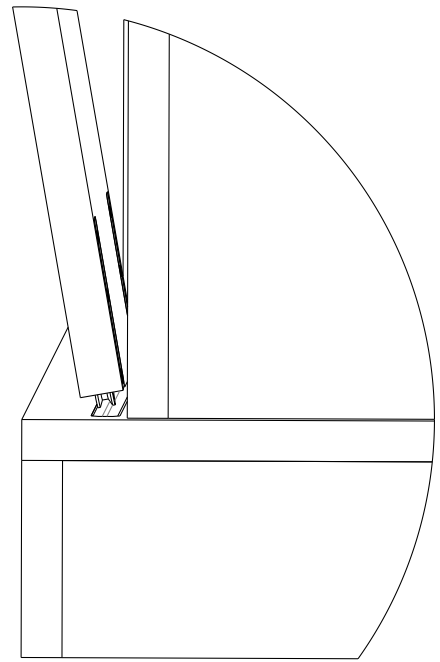
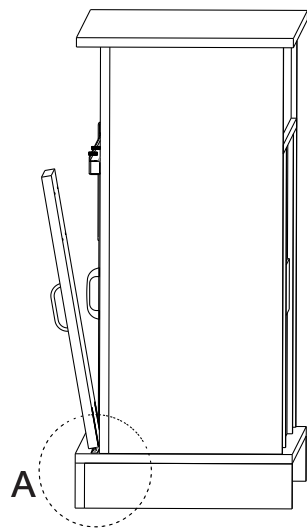

ZOOM VIEW "A"

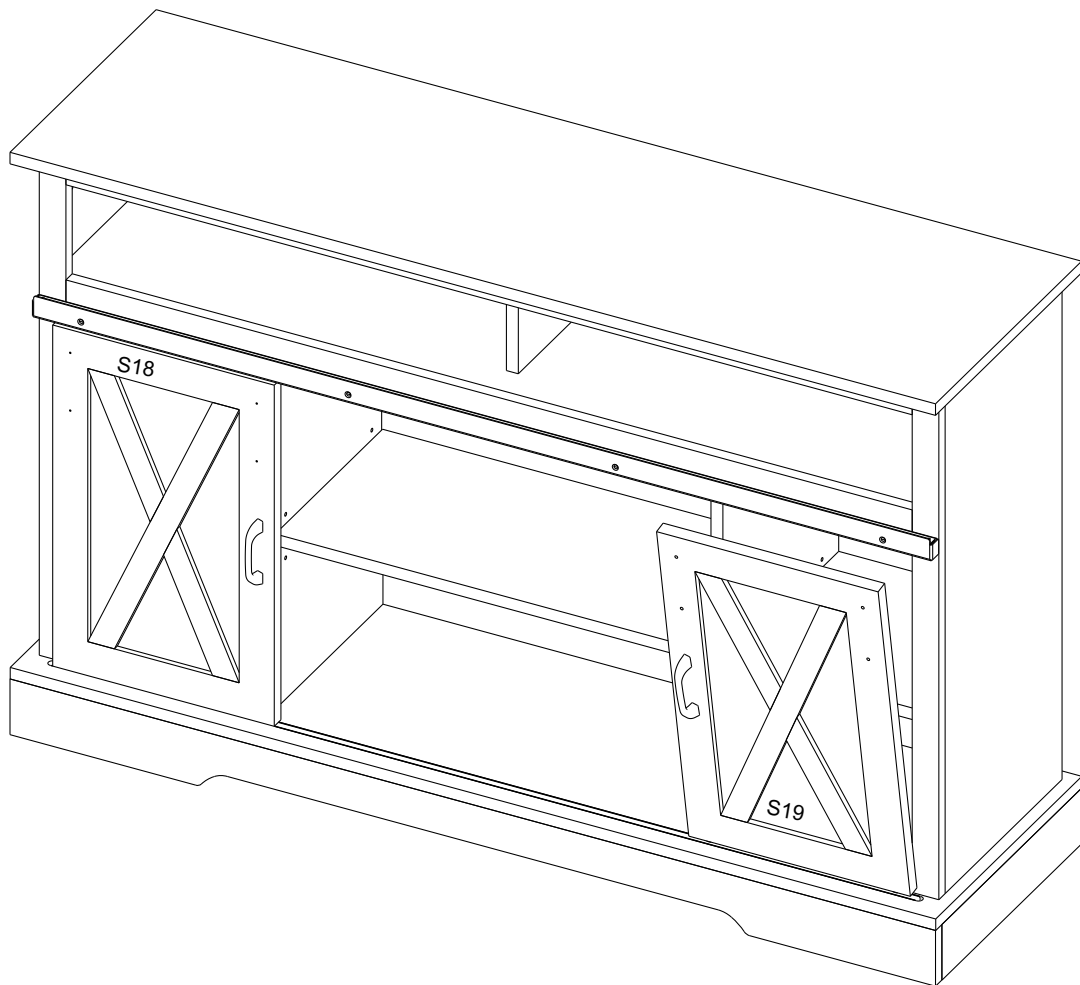

Place Parts (S18,S19) one by one as above picture.

Step 29

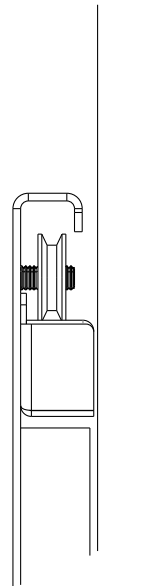
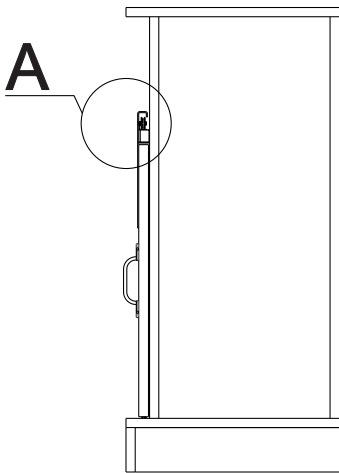

Large View of "A"

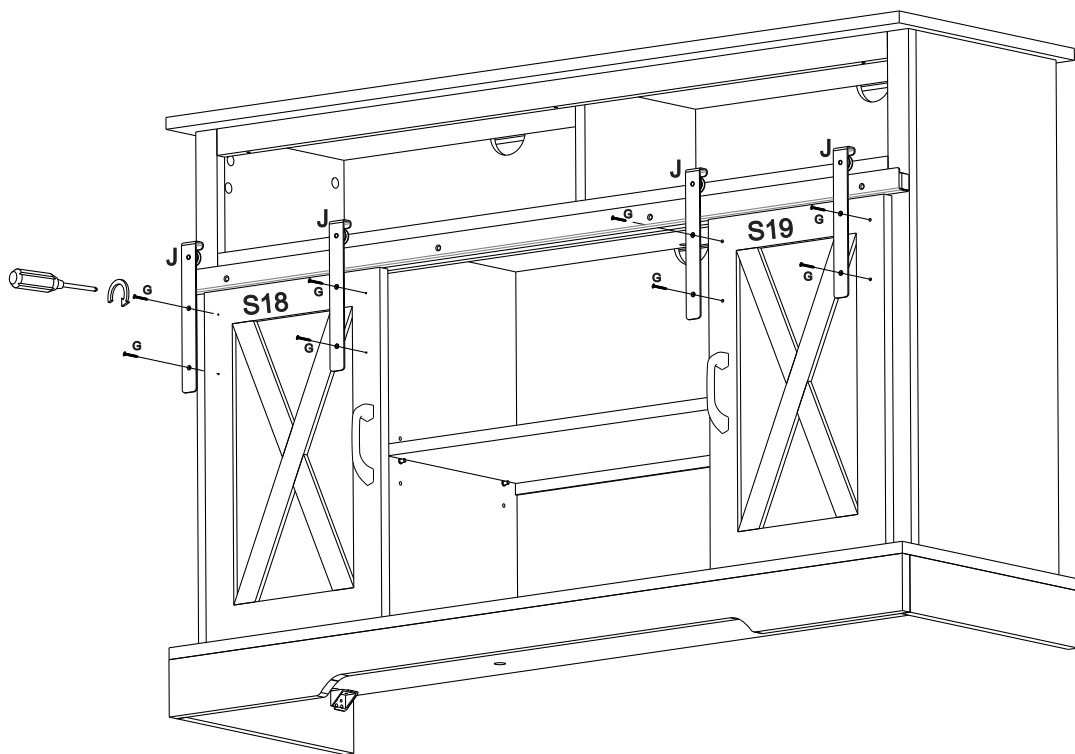

Attach Part (J) to (S18,S19) with screw (G) by screw driver.
After fixing it look like a large view of "A".

Step 30

Final Assembly

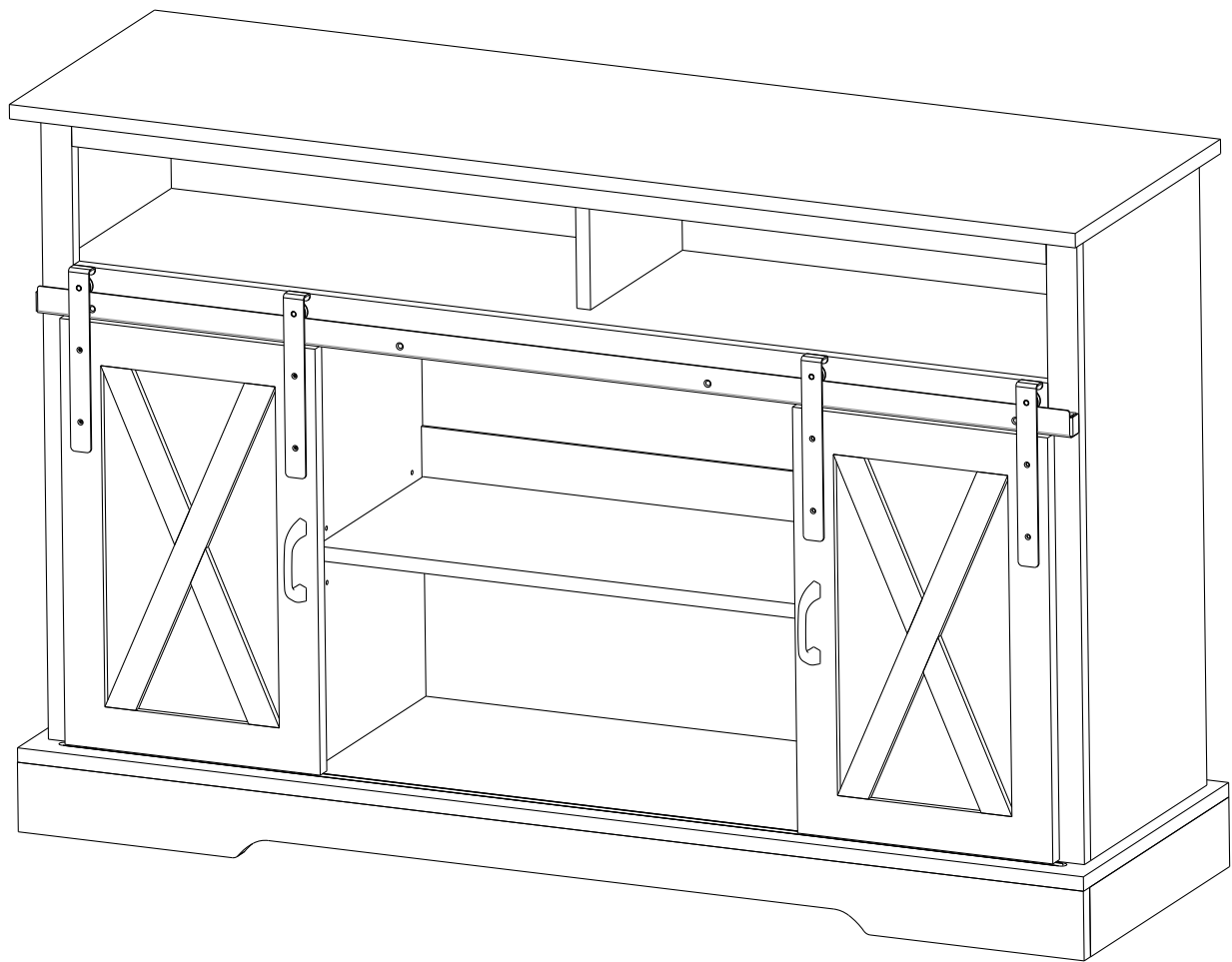

Final Assembly Look like.